

IN BUILDING RADIO DISTRIBUTION AGREEMENT

This Agreement ("Agreement") is made as of Dec. 23, 2014 ("Effective Date") between the **City of Jacksonville**, a whose principal place of business is 214 N. Hogan Street, Jacksonville, Florida 32202 ("Licensor"), and Verizon Wireless Personal Communications LP d/b/a Verizon Wireless, whose principal place of business is One Verizon Way, Mail Stop 4AW100, Basking Ridge, NJ 07920, ("Licensee").

Background

Licensor owns the Premises and a distributed antenna system ("DAS"). Licensor and Licensee desire to enter into this Agreement to allow Licensee to connect its equipment ("Licensee Equipment") to and use the DAS.

NOW THEREFORE, both parties agree to enter into this License Agreement on the terms and conditions set forth herein.

Agreement

1. License. Licensor hereby licenses to Licensee certain spaces on and within Licensor's premises at 337 West Adams Street, Jacksonville, Duval County, Florida, which is also known as the Duval County Courthouse, (the "Premises") to place Licensee Equipment on the Premises and connect such equipment to and use the DAS. The components and design principles of the DAS are described and shown on Exhibit A. Licensee Equipment shall include microcell(s), rerad(s) or other similar or comparable in-building radio-distribution devices and the antennas serving them together with cables, fibers or the equivalent connecting such Licensee Equipment, whether through conduit or otherwise, to the DAS, which Licensee Equipment shall be for the exclusive use of Licensee. Licensee may replace and augment Licensee Equipment or portions thereof with similar or comparable equipment and modify any frequencies upon which such equipment operate as needed to provide in-building coverage. The physical space to be used by the Licensee Equipment is shown on Exhibit B.

2. Construction, Installation, Maintenance & Interference. All construction, installation and maintenance of the DAS shall be performed by Licensor or its contractors in a safe manner consistent with current wireless industry engineering and construction standards and practices, lien-free. All construction, installation and maintenance of the Licensee Equipment shall be performed by Licensee or its contractors in a safe manner consistent with current wireless industry engineering and construction standards and practices, lien-free. Licensee, with Licensor's cooperation as or if needed, shall obtain any required governmental and quasi-governmental permits, licenses, approvals, and authorizations for the Licensee Equipment and Licensor shall obtain all required governmental and quasi-governmental permits, licenses, approvals, and authorizations for the DAS. Licensee agrees to only install radio equipment of the type and frequency that will not cause measurable interference to the equipment of Licensor or other tenants of the Premises existing as of the date of this Agreement. Should Licensee's equipment cause measurable interference, and provided Licensor gives written notice, Licensee will take all steps necessary to correct and eliminate the interference. Licensor agrees that it

and/or any other tenant of the Premises (current or future) will install only such radio equipment, including in the DAS, that is of the type and frequency that will not cause measurable interference to the existing equipment of the Licensee. Should Licensor's or another tenants' equipment cause measurable interference with Licensee, and provided Licensee gives written notice to Licensor of it, Licensor will take all steps necessary to correct and eliminate the interference, including causing other tenants of the Premises causing such interference to correct and eliminate the interference. The parties acknowledge that there will not be an adequate remedy at law for non-compliance with the provisions of this paragraph and therefore, either party shall have the right to specifically enforce the provisions of this paragraph in a court of competent jurisdiction.

3. Power and Fiber. Licensor will supply electrical power in quality, quantity, and levels currently available at the Premises, and customary for the operation of Licensee Equipment, at Licensor's cost. Notwithstanding the foregoing, no interruption or discontinuance of such electrical power will render Licensor liable to Licensee for damages or relieve Licensee of any of its obligations hereunder, except as such results from the acts or omissions of the Licensor. Licensor also grants to Licensee an easement for fiber/T-1 running from the nearest public right of way to the Premises to the extent necessary to serve the DAS, in Licensee's sole determination.

4. Ownership & Control. The Licensee Equipment is personal property of the Licensee and the Licensee at all times owns and controls the Licensee Equipment. Licensor and Licensee agree, and Licensor shall so inform, any purchaser or mortgagee of the Premises, of this Agreement and that all equipment forming a part of the Licensee Equipment shall be and remain the property of Licensee under all circumstances, under Licensee's exclusive control, free and clear of any liens or encumbrances other than those permitted by Licensee, and shall be deemed to be and remain personal property and not part of the real estate on which the same are located. The DAS is personal property of Licensor and Licensor at all times owns and controls the DAS. Licensee shall have no obligation with respect to the maintenance, repair or replacement of the DAS, which shall be done solely by Licensor. Licensor represents and warrants that the DAS shall remain in good operating condition at all times. The Licensee shall have the right to make any required connections and/or attachments to the DAS in order to allow the Licensee to monitor the DAS, including summary alarm notification in the event of a DAS failure, from outside of the Premises via Licensee's infrastructure.

5. Consideration. In consideration for the rights granted herein, Licensor's premises will receive the benefits of enhanced wireless communications arising from operation of the Licensee Equipment, which Licensee acquires solely at its expense for its exclusive use and which is owned by Licensee. The design, construction, equipment, installation, maintenance, repair and upgrade of the Licensee Equipment shall be at Licensee's sole cost, and Licensor shall incur no cost for this project.

6. Access. Licensor agrees to provide Licensee, its employees and/or agents access during business hours to the Premises for the purpose of design, construction, installation, upgrading, maintenance and repair of the Licensee Equipment, except for emergencies, in which case Licensee, its employees and/or agents shall have access twenty-four hours a day, seven days a week.

7. Term; Default; Termination. The term of this Agreement shall be five (5) years with four (4) automatic five (5)-year renewal terms, unless the Licensee terminates it at the end of the then-current term by giving the Licensor written notice of intent to terminate at least six (6) months prior to the end of the then current term.

Notwithstanding anything to the contrary contained herein, Licensee shall have the right to terminate this Agreement at any time without cause provided that thirty (30) days prior notice is given the Licensor. In the event Licensee defaults in the performance of any of its covenants or obligations hereunder and such default continues for a period of sixty (60) days after written notice thereof from Licensor (unless the nature of the event takes longer to cure and Licensee commences a cure within the time period and diligently pursues it thereafter), Licensor may thereafter terminate this Agreement by written notice to Licensee. Upon any such termination, Licensee shall remove the Licensee Equipment and repair or restore any damage to Licensor's premises resulting therefrom, normal wear and tear excepted. This Agreement may only be terminated in accordance with its terms.

8. Indemnification, Insurance, Waiver of Consequential Damages. Licensee shall indemnify and hold Licensor harmless against any claim of liability or loss or bodily injury or property damage resulting from or arising out of the acts or omissions of Licensee or its agents in connection with the use and occupancy of the Premises in connection with the Licensee Equipment, excepting claims or damages as may be due or caused by the acts or omissions of the Licensor or its agents. Licensee shall procure and maintain throughout the term of this Agreement commercial general liability insurance with limits of not less than two million dollars (\$2,000,000) for bodily injury, death, or for damage or injury to or destruction of property (including the loss of use thereof) per any one occurrence. Licensor agrees that Licensee may self insure. The parties waive and release any and all rights of action for negligence against the other which may arise on account of damage to the Premises or to property, resulting from any fire, or other casualty of the kind covered by standard fire insurance policies with extended coverage, regardless of whether or not, or in what amounts, such insurance is now or hereafter carried by Licensee. These waivers and releases shall apply between the parties and to any claims under or through either party as a result of any asserted right of subrogation. All policies of insurance covering property damage obtained by Licensee concerning or including the Premises or property shall waive the insurer's right of subrogation against Licensor. The foregoing notwithstanding, whether the cause of any damage, loss or liability is insurable, insured or not insured, foreseen or unforeseen, in no event shall either party be responsible or liable to the other party for anticipatory profits or any indirect, special, incidental or consequential damages of any kind or nature arising directly or indirectly in connection with the construction, use or operation of the Premises or the exercise of any rights related thereto, whether based on an action or claim in contract or tort, including negligence, strict liability or otherwise.

9. Quiet Enjoyment. Licensor covenants that Licensee, upon performing all the covenants, shall peaceably and quietly have, hold and enjoy the Premises and Licensor further covenants that Licensor is seized of good and sufficient title and interest to the Premises and has full authority to enter into this Agreement.

Licensor represents, warrants and covenants that no lead paint, asbestos or other hazardous substance, as defined by any applicable state, federal or local law or regulation, is present at any Premises; Licensor owns or leases the Premises or otherwise has the right to grant the license given in this Agreement; the Licensor has obtained all required consents or approvals from any landlord, mortgagee or other person or entity having an interest therein; and Licensor is not in default under any lease with the owner of the Premises and the term of such lease extends to the term of this Agreement with any and all renewal terms.

10. Assignment. This Agreement may be assigned by either party to its principal, affiliates, subsidiaries or any entity which acquires all or substantially all of its assets in the applicable Federal Communications Commission license area by reason of a merger, acquisition or other business reorganization without the consent of the other party. As to other parties, any sale, assignment or transfer by either party must be with the written consent of the other party, such consent not to be unreasonably withheld.

11. Notices & Contacts. All notices hereunder must be in writing and shall be sent certified mail, return receipt requested, to Licensor at 214 N. Hogan Street, Jacksonville, Florida 32202 and to Licensee at 180 Washington Valley Road, Bedminster, NJ 07921, Attention Network – Real Estate.

12. Miscellaneous. This Agreement contains all agreements, promises and understandings between the Licensor and the Licensee regarding this transaction, and no oral agreement, promises or understandings shall be binding upon either the Licensor or the Licensee in any dispute, controversy or proceeding. This Agreement may not be amended or varied except in a writing signed by all parties. This Agreement shall extend to and bind the heirs, personal representatives, successors and assigns hereto. The failure of either party to insist upon strict performance of any of the terms or conditions of this Agreement or to exercise any of its rights hereunder shall not waive such rights and such party shall have the right to enforce such rights at any time. This Agreement and the performance thereof shall be governed interpreted, construed and regulated by the laws of the state in which the Premises is located without reference to its choice of law rules.

[Signature Page Follows]

IN WITNESS WHEREOF, the parties hereto have set their hands, intending to be bound, as of the Effective Date.

LICENSEE: Verizon Wireless Personal Communications LP d/b/a Verizon Wireless

Luzene Arlish
WITNESS

By: [Signature]
Aparna Khurjekar
Area Vice President Network
Date: 11/20/2014

Kim Schwalb
WITNESS

LICENSOR: The City of Jacksonville

[Signature]
Witness

By: [Signature]
Name: ALVIN BROWN
Its: MAYOR
Date: 12/19/14

[Signature]
James R. McCann
Corporate Secretary



Karen Bowling
Chief Administrative Officer
For: Mayor Alvin Brown
Under Authority of:
Executive Order No. 2013-04

[Signature]
Director of Finance
City Contract No. 7720-24

*for
won*

Form Approved:

[Signature]
Office of General Counsel

EXHIBIT A

(The components and design principles of the DAS are described and shown herein)

Licensee is referred to as “Verizon” or “Verizon Wireless” herein.



PAR0

Site:Verizon PCS
Sector:8 CDMA/EVDO Carriers

Site:Verizon 700 MHz
Sector:2 LTE Carriers



CBC1

ANT132

Site:Public Safety 800 MHz
Sector:12 Channels

ANT0

Site:Public Safety 700 MHz
Sector:8 Channels

ANT131

Sprint will sell Donor antenna they select to cover all their required bands

Site:AT&T
Sector:1 Carrier
Band:700 MHz

BTS2

Site:AT&T
Sector:1 Carrier
Band:1900 MHz - PCS

BTS1

Site:AT&T
Sector:1 Carrier
Band:850 MHz - Cellular

BTS0

AT&T will supply Cellular, PCS, and 700 MHz LTE BTS's and equipment and labor for connecting to ION-B Head End Equipment

Site:T-Mobile AWS
Sector:4 WCDMA Carriers

Site:T-Mobile PCS
Sector:4 GSM Carriers

ANT1

Donor antennas will be mounted on the side walls of the stairwell buildings



TITLE	System Overview	DESIGNER	Rick Rausch
COMPANY	Longent LLC	DATE	1/18/2012

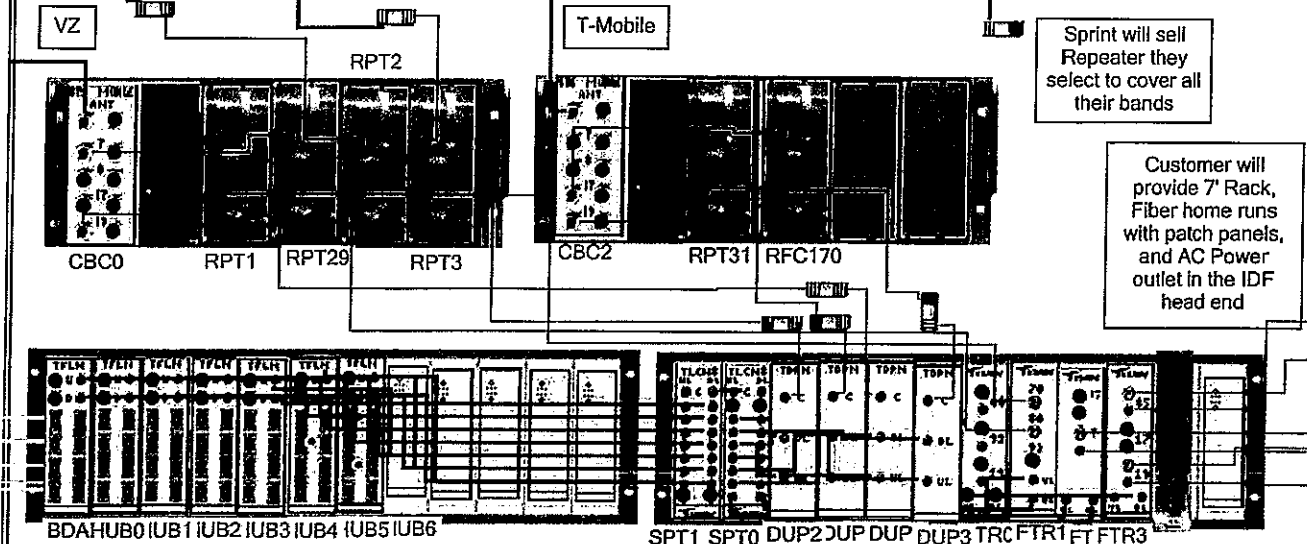

Sprint will sell Repeater they select to cover all their bands

Customer will provide 7' Rack, Fiber home runs with patch panels, and AC Power outlet in the IDF head end

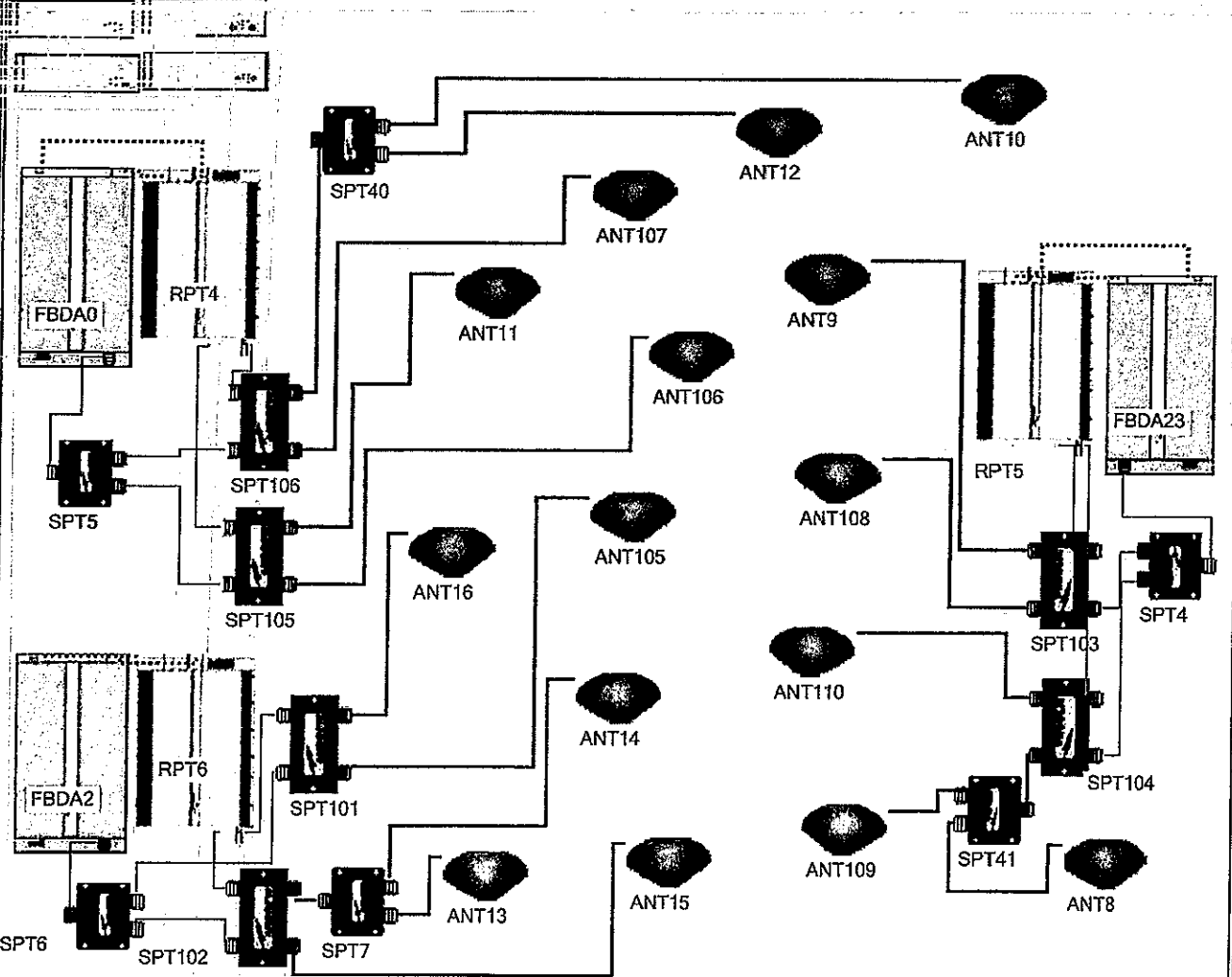

	TITLE	System Overview	DESIGNER
		Duval County Courthouse	Rick Rausch
	COMPANY	Longent LLC	DATE
			1/18/2012

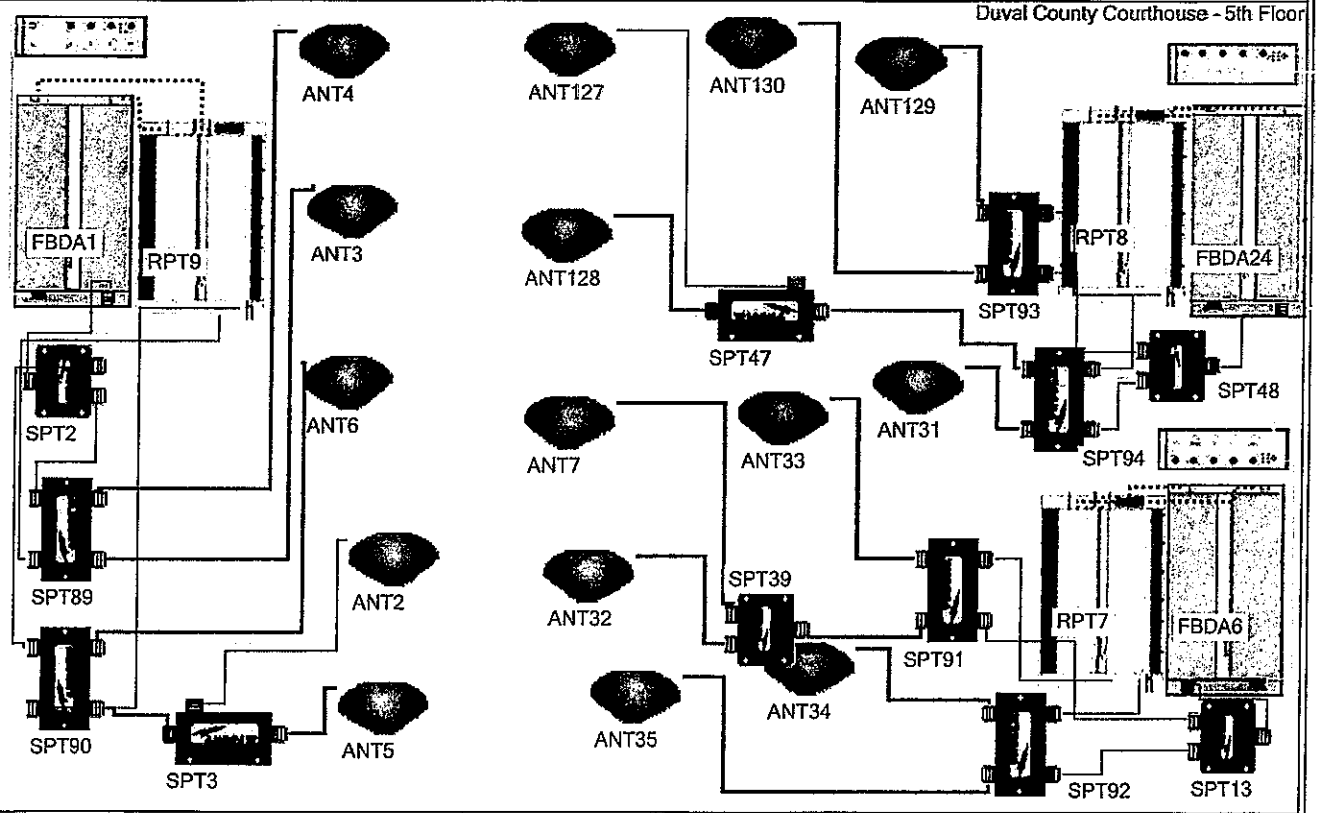
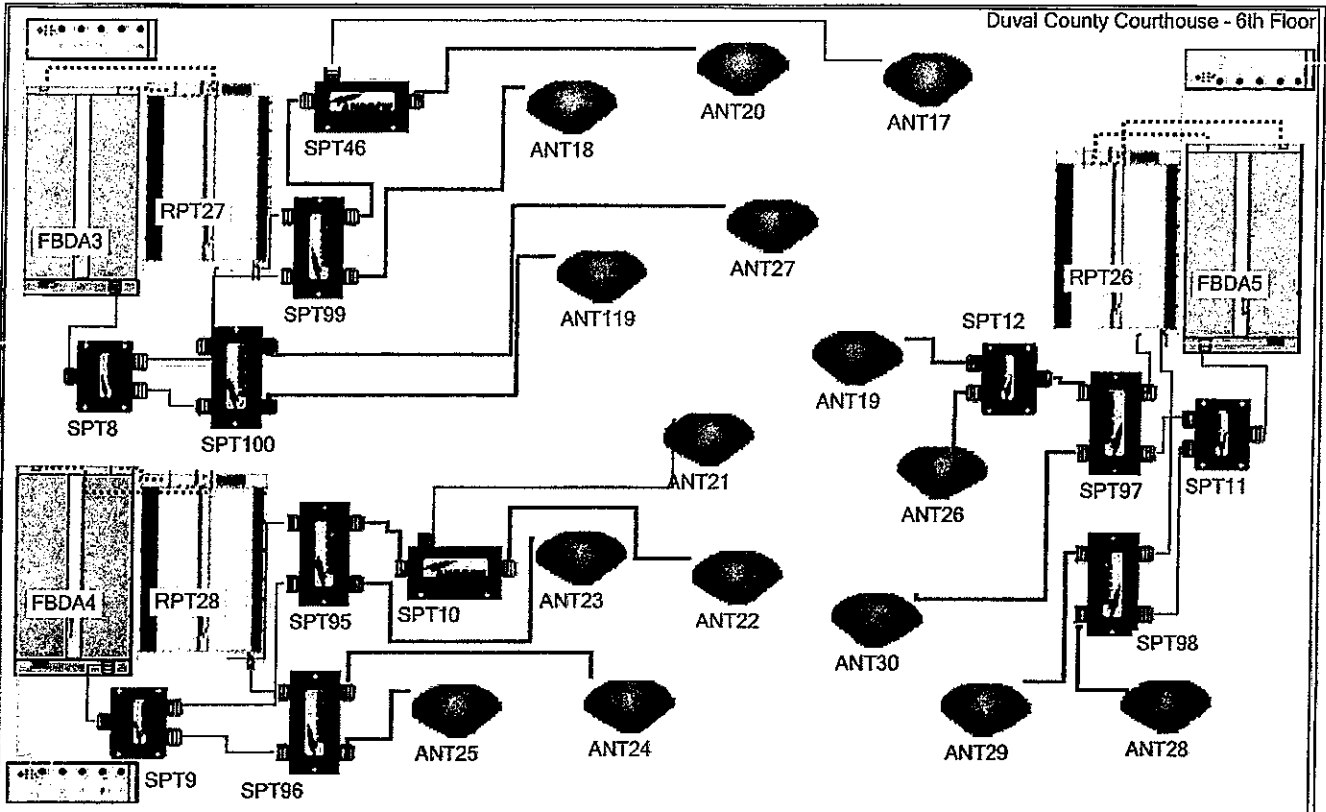

	TITLE	System Overview	DESIGNER
		Duval County Courthouse	Rick Rausch
	COMPANY	Longent LLC	DATE
			1/18/2012

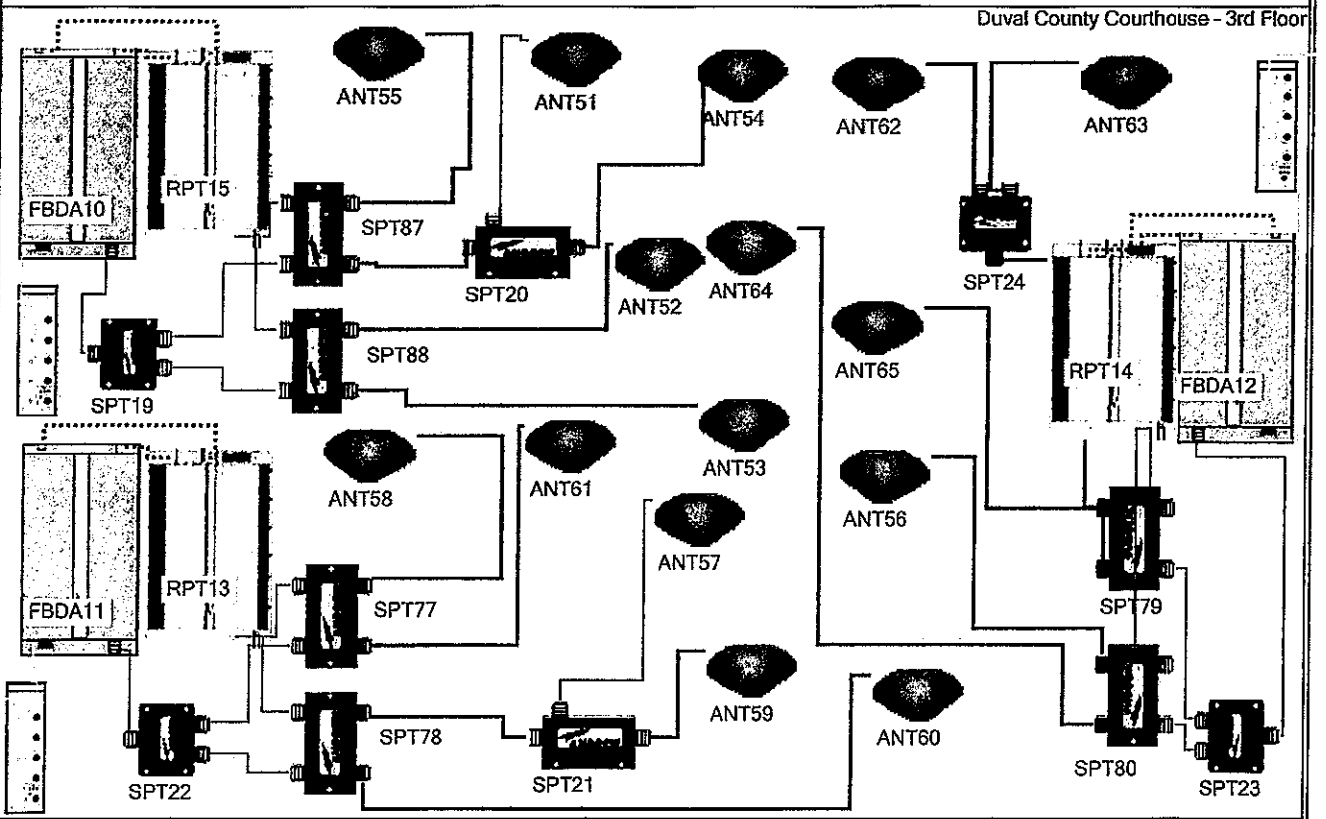
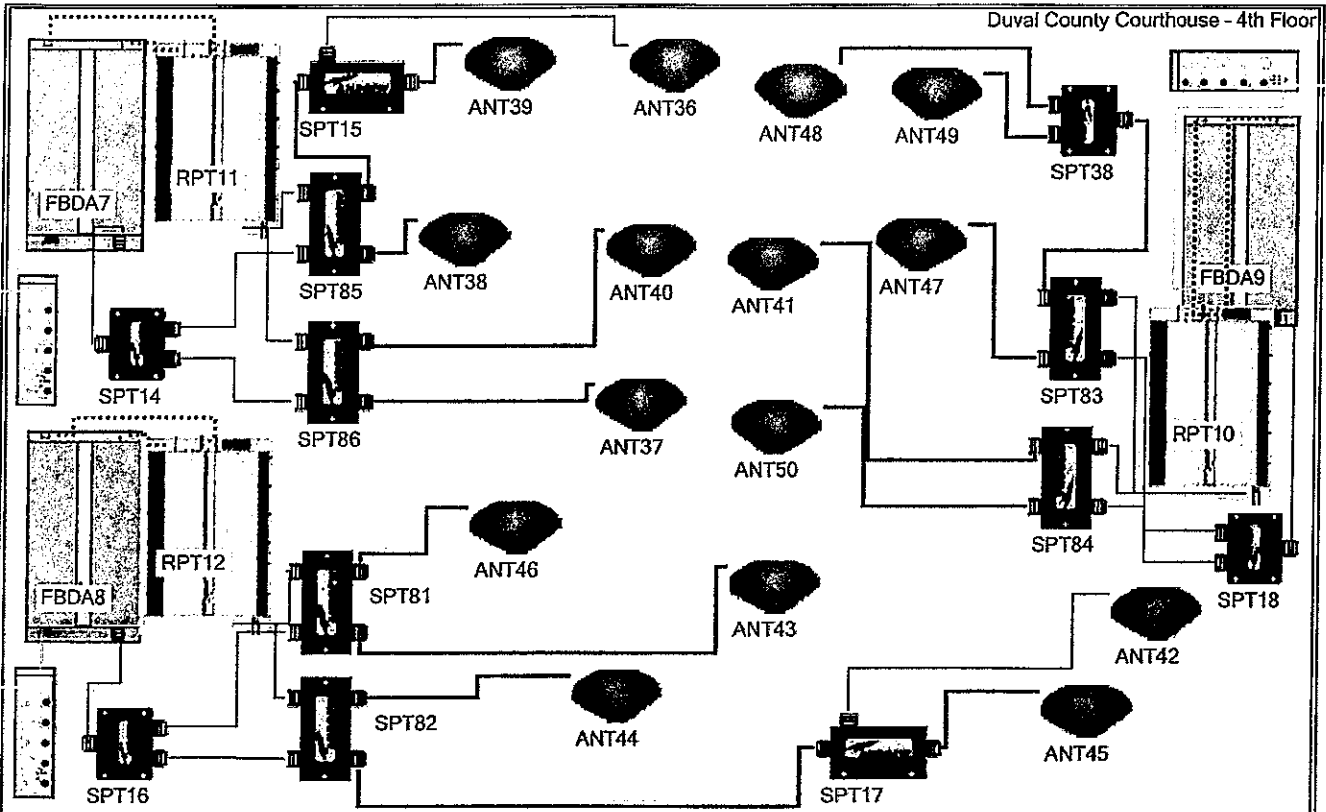

	TITLE	System Overview	DESIGNER	Rick Rausch
	COMPANY	Duval County Courthouse	DATE	1/18/2012
		Longent LLC		

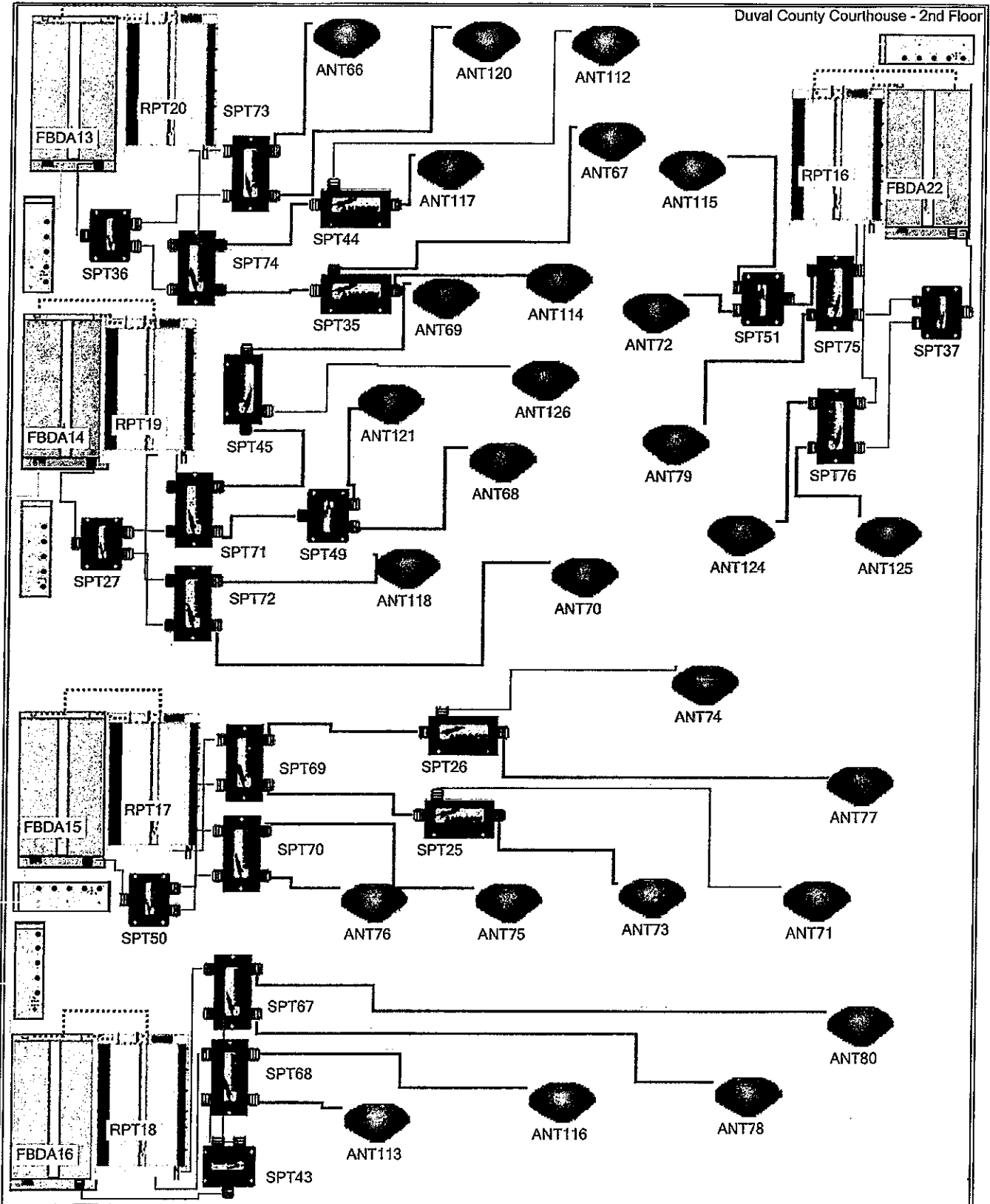

	TITLE	System Overview	DESIGNER
		Duval County Courthouse	Rick Rausch
	COMPANY	Longent LLC	DATE
			1/18/2012

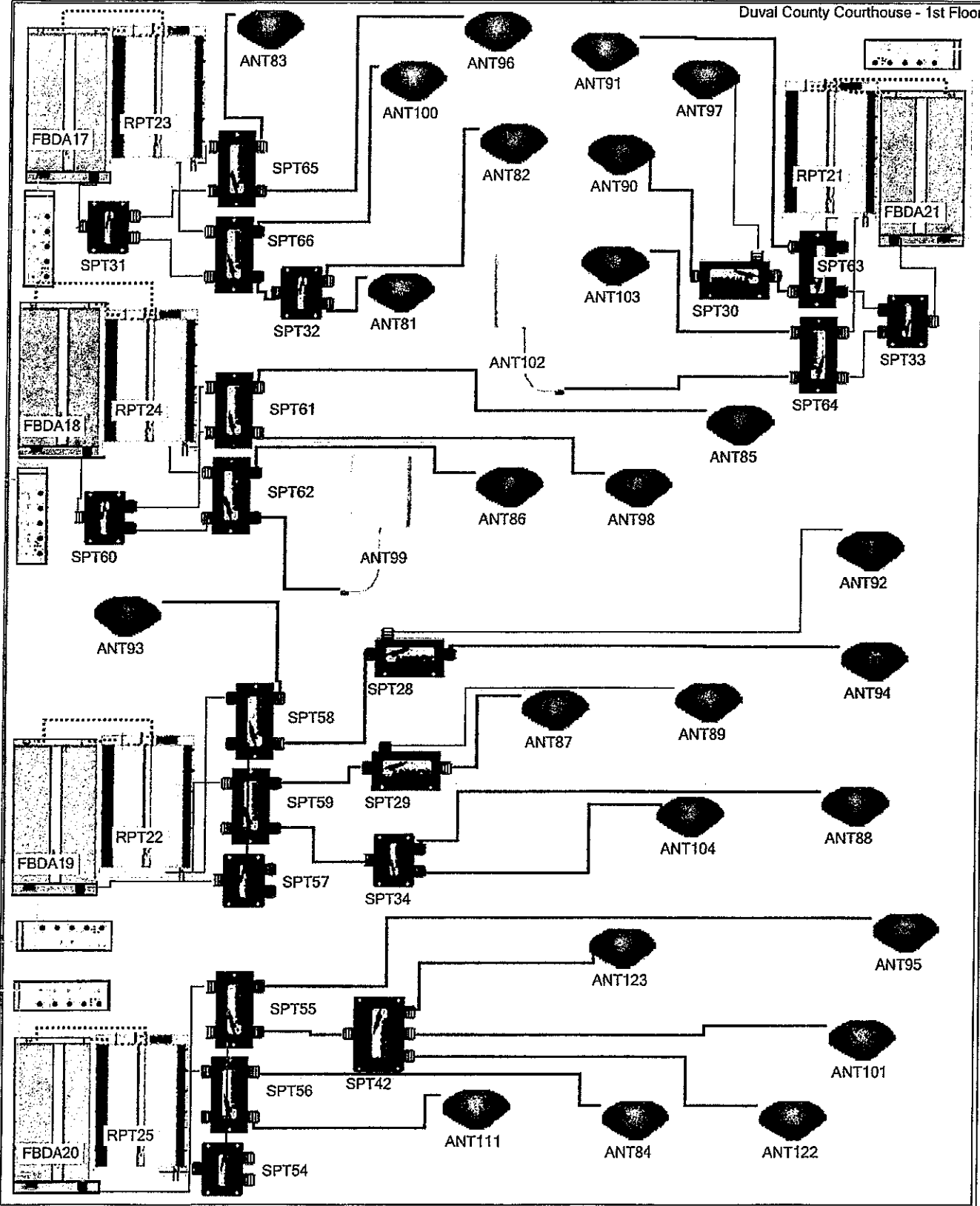

	TITLE	System Overview	DESIGNER
		Duval County Courthouse	Rick Rausch
	COMPANY	Longent LLC	DATE
			1/18/2012

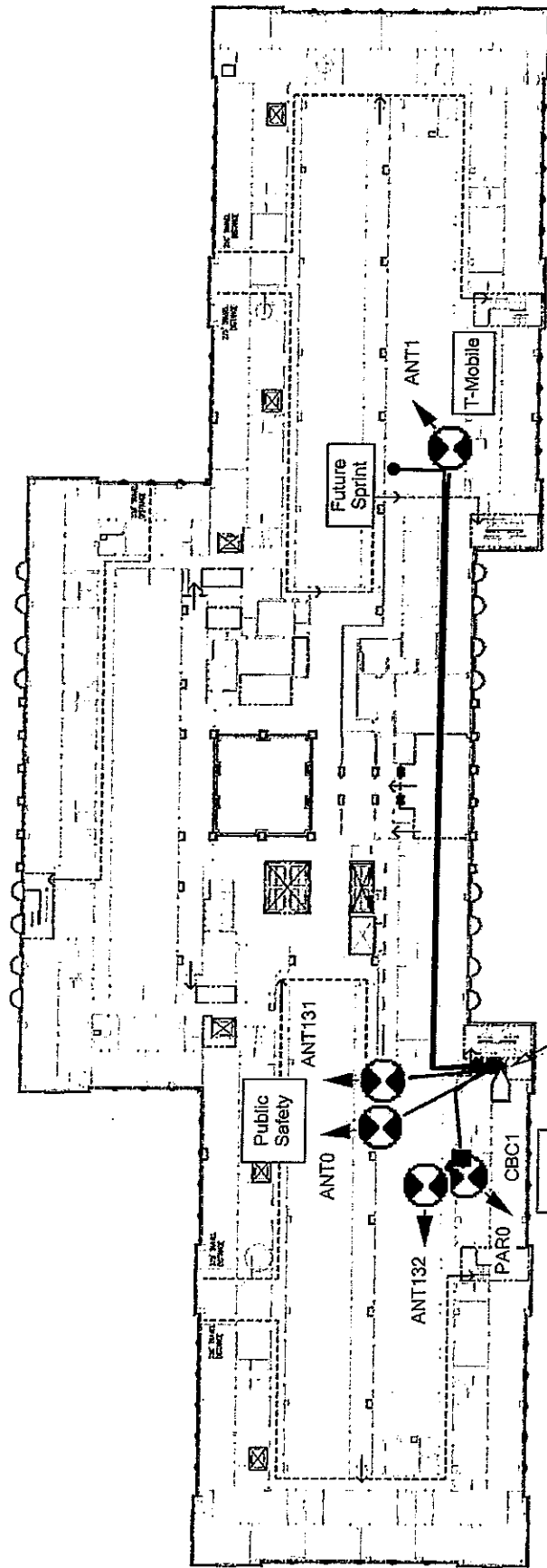

VIA46 to MSC29 on 7th Floor
 VIA45 to MSC28 on 7th Floor
 VIA43 to CBC0 on 7th Floor
 VIA41 to MSC28 on 7th Floor
 VIA53 to CBC2 on 7th Floor

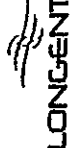
	TITLE	Roof
	DESIGNER	Rick Rausch
	COMPANY	Duval County Courthouse
	DATE	1/18/2012
		Longent LLC

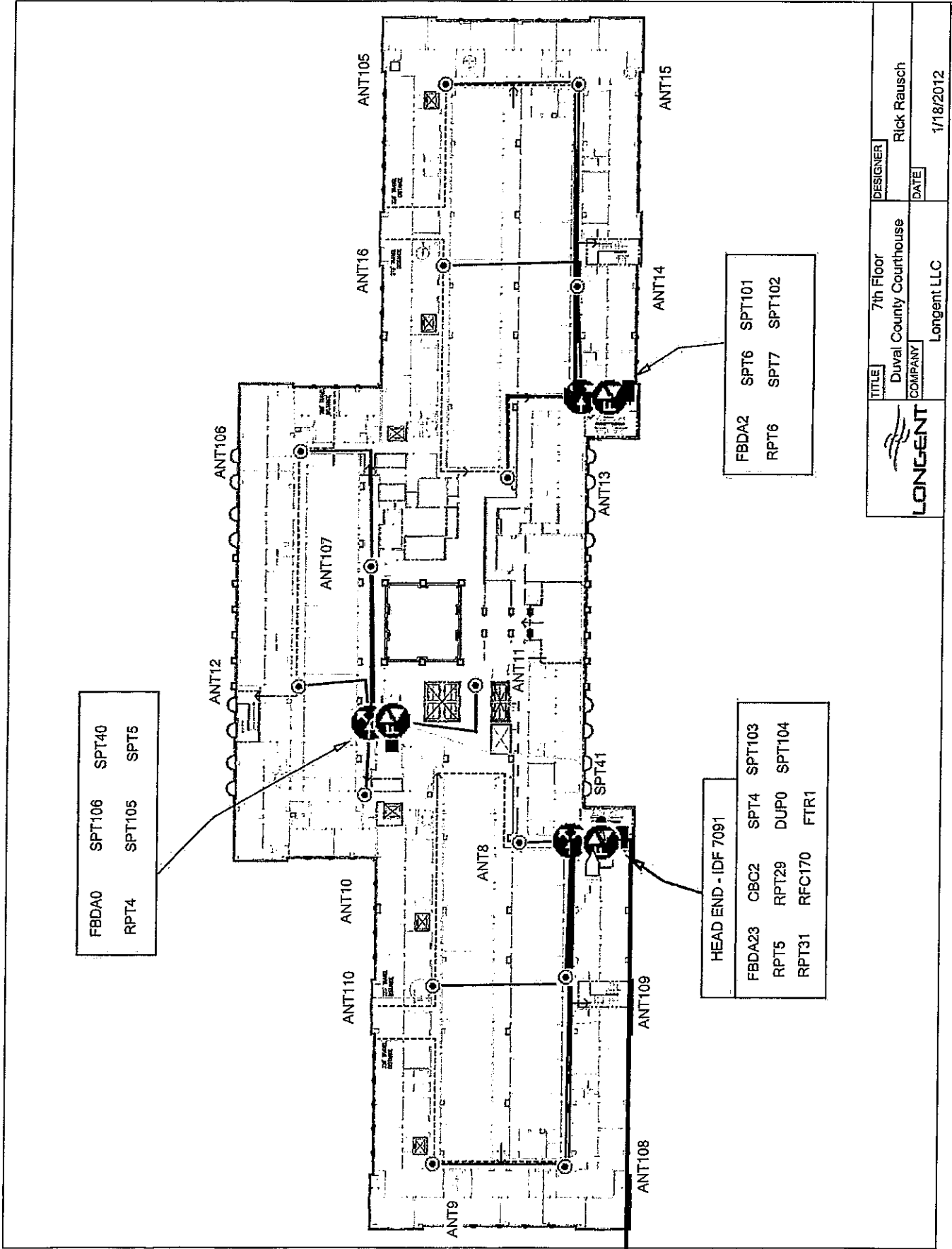

FBDA0 SPT106 SPT40
RPT4 SPT105 SPT5

FBDA2 SPT6 SPT101
RPT6 SPT7 SPT102

HEAD END - IDF 7091
FBDA23 CBC2 SPT4 SPT103
RPT5 RPT29 DUP0 SPT104
RPT31 RFC170 FTR1

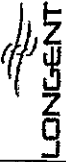
	TITLE	7th Floor	DESIGNER	Rick Rausch
	COMPANY	Duval County Courthouse	DATE	1/18/2012

Legend

	Antenna
	Fiber BDA
	Repeater
	Splitter
	Splitter
	Via

VIA24 to PP5 on 7th Floor
 FBDA5 SPT11 SPT97
 RPT26 SPT12 SPT98

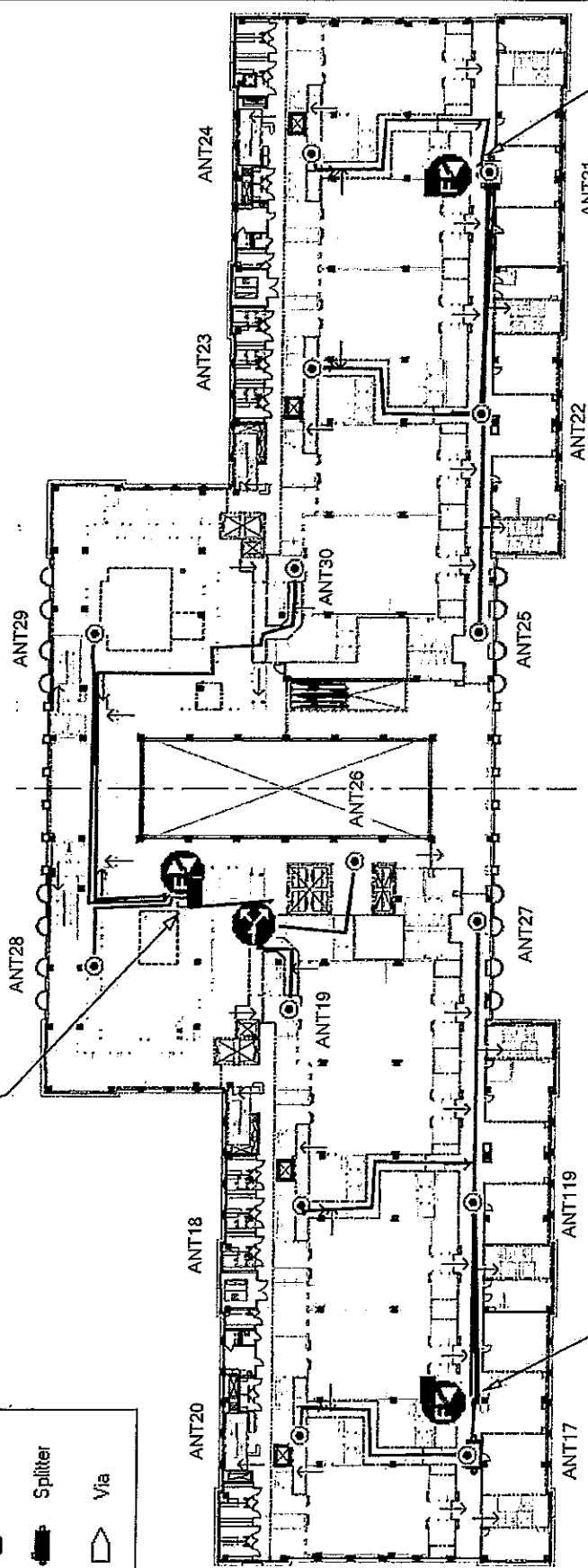

VIA3 to PP5 on 7th Floor
 FBDA4 SPT9 SPT95
 RPT28 SPT96

VIA0 to PP2 on 7th Floor
 RPT27 SPT8 SPT99
 FBDA3 SPT100

	TITLE	6th Floor
	COMPANY	Longent LLC
	DESIGNER	Rick Flausch
	DATE	1/18/2012

Photogrametric

- Antenna
- Fiber BDA
- Repeater
- Splitter
- Splitter
- Via

RPT7 SPT13 SPT91
 FBDA6 SPT39 SPT92
 VIA26 to PP5 on 7th Floor





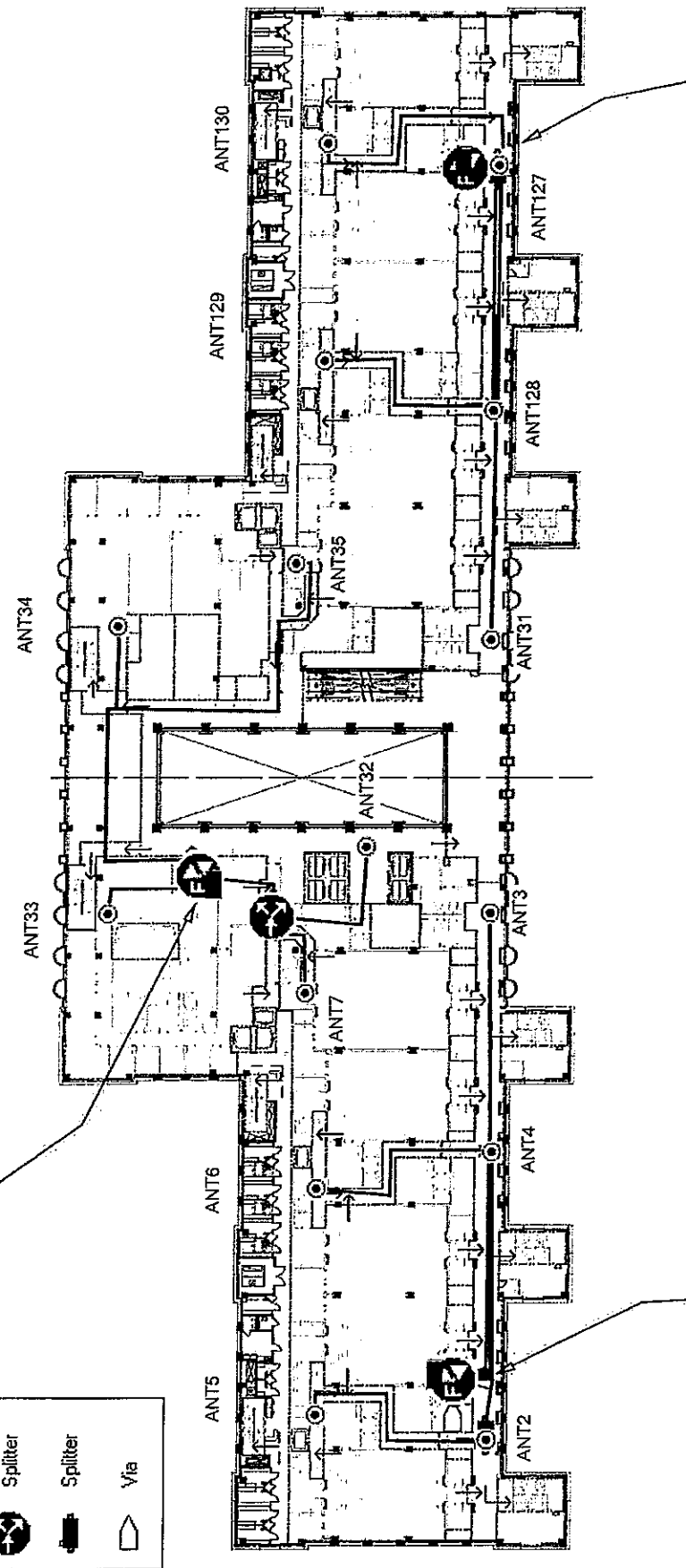

VIA28 to PP2 on 7th Floor
 FBDA1 RPT9 SPT2
 SPT89 SPT90

VIA38 to PP5 on 7th Floor
 FBDA24 RPT8 SPT93
 SPT48 SPT47 SPT94



	TITLE	5th Floor	DESIGNER	Rick Rausch
	COMPANY	Duval County Courthouse	DATE	
		Longent LLC		1/18/2012

Photoarams Legend

-  Antenna
-  Fiber BDA
-  Repeater
-  Splitter
-  Splitter
-  Via

VIA8 to PP3 on 7th Floor
 FBDA9 RPT10 SPT83
 SPT18 SPT38 SPT84

VIA4 to PP5 on 7th Floor
 FBDA7 RPT11 SPT14
 SPT85 SPT86

VIA6 to PP5 on 7th Floor
 FBDA8 RPT12 SPT16
 SPT81 SPT82

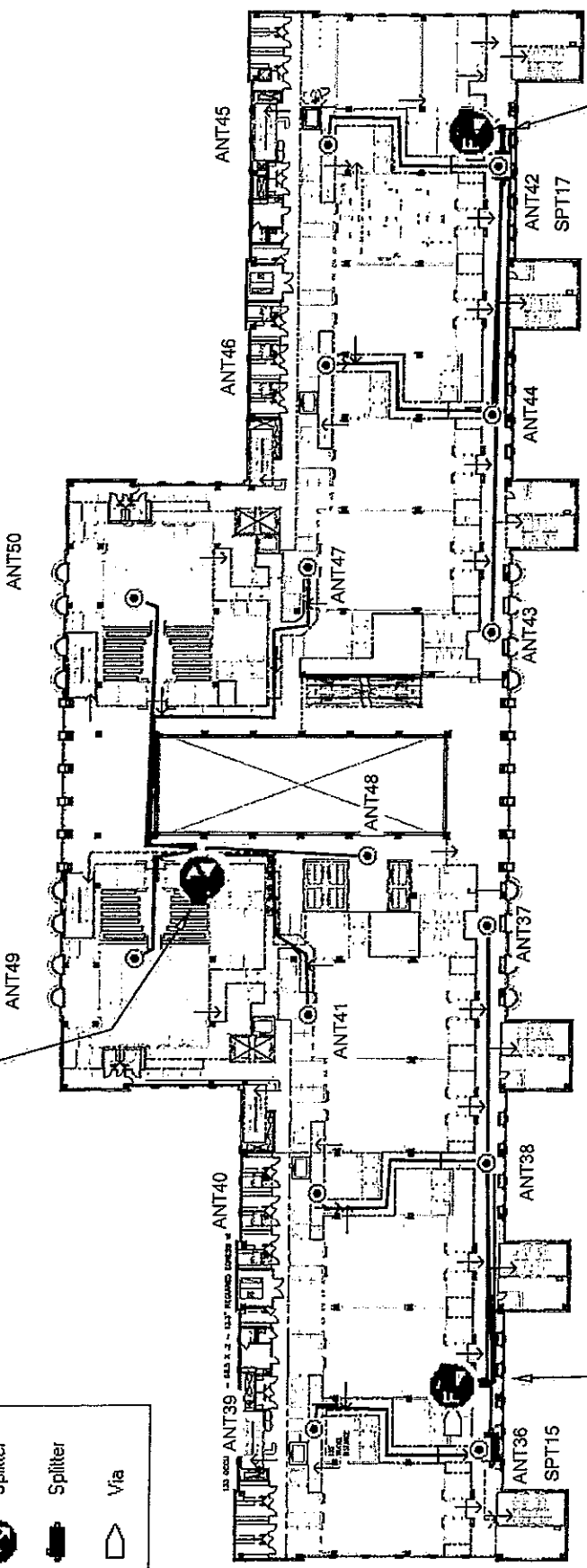

LONGENT

TITLE	4th Floor	DESIGNER	
COMPANY	Duval County Courthouse	DATE	
	Longent LLC	DESIGNER	Rick Rausch
		DATE	1/18/2012







VIA14 to PP3 on 7th Floor
 FBDA12 RPT14 SPT24 SPT23 SPT80 SPT79

VIA10 to PP2 on 7th Floor
 FBDA10 RPT15 SPT19 SPT87 SPT88

VIA12 to PP2 on 7th Floor
 FBDA11 RPT13 SPT22 SPT77 SPT78

1 3RD FLR. LIFE SAFETY PLAN

Legend

-  Antenna
-  Fiber BDA
-  Repeater
-  Splitter
-  Splitter
-  Via

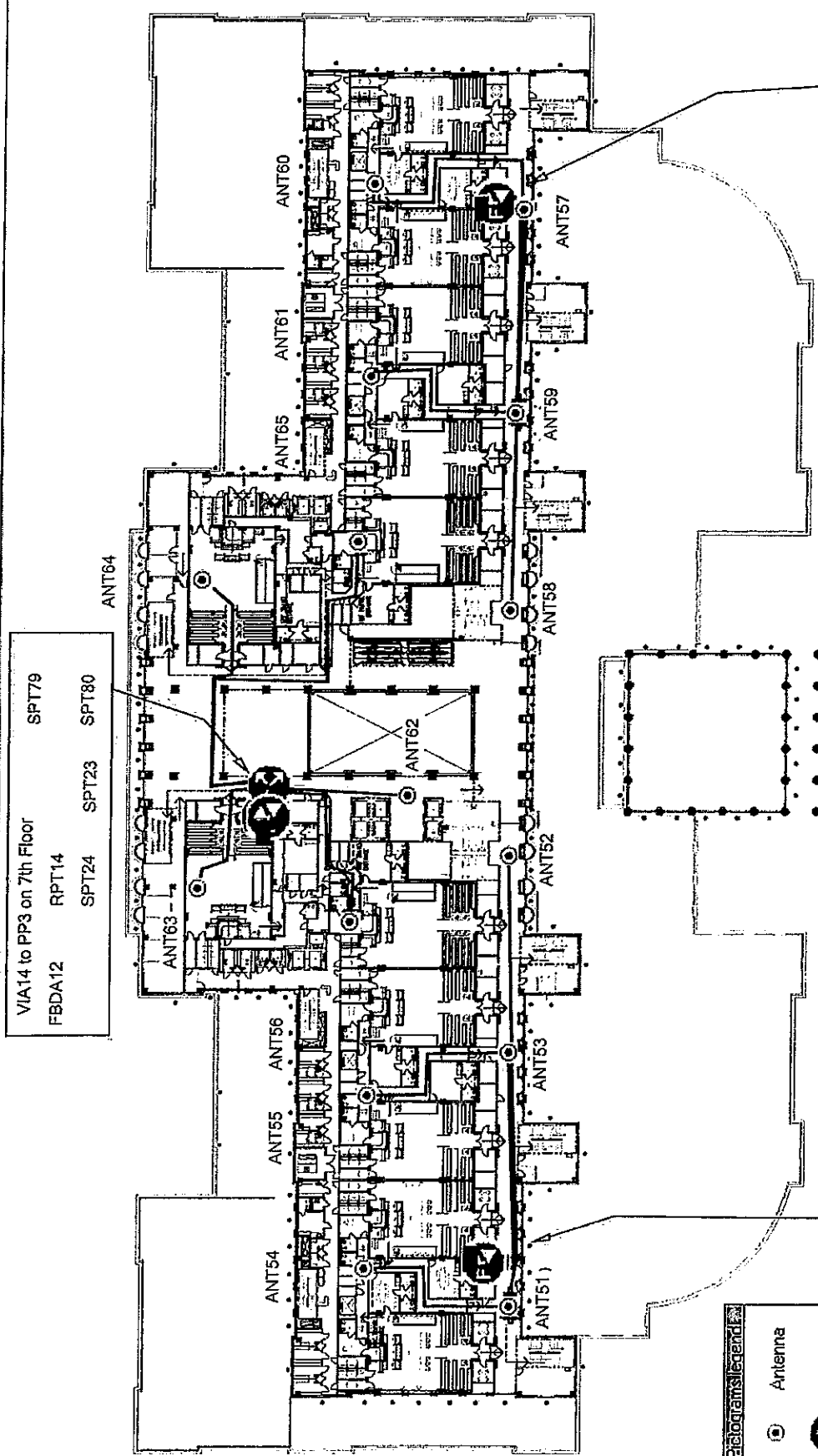

LONGENT

TITLE: 3rd Floor
 Duval County Courthouse
 COMPANY: Longent LLC

DESIGNER: Rick Rausch
 DATE: 1/18/2012

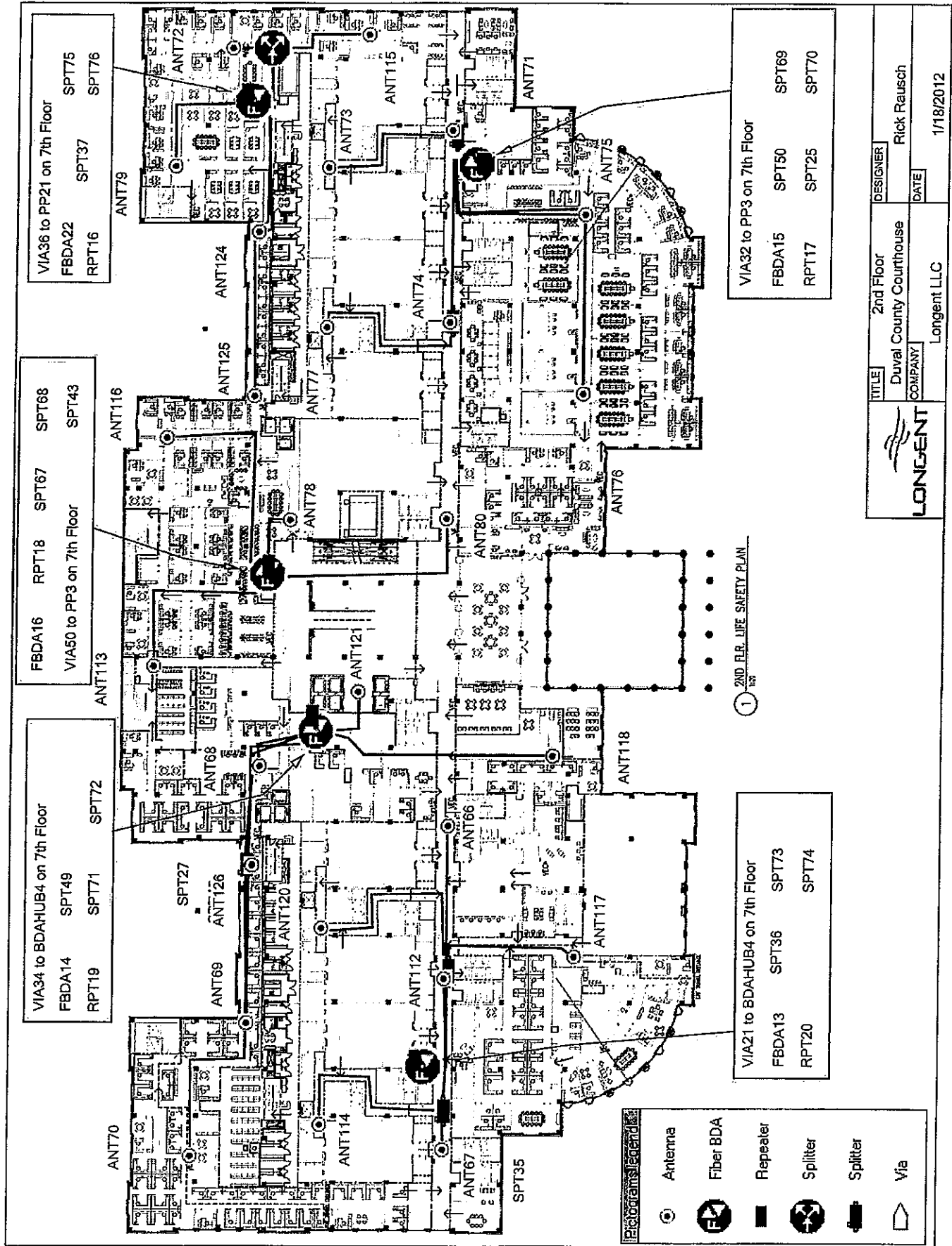

VIA36 to PP21 on 7th Floor
 FBDA22 SPT37 SPT75
 RPT16 SPT37 SPT76

FBDA16 RPT18 SPT67 SPT68
 VIA50 to PP3 on 7th Floor SPT43
 ANT113

VIA34 to BDAHUB4 on 7th Floor
 FBDA14 SPT49 SPT72
 RPT19 SPT71

VIA32 to PP3 on 7th Floor
 FBDA15 SPT50 SPT69
 RPT17 SPT25 SPT70

VIA21 to BDAHUB4 on 7th Floor
 FBDA13 SPT36 SPT73
 RPT20 SPT74

LEGEND

- Antenna
- Fiber BDA
- Repeater
- Splitter
- Splitter
- Via

LONGENT

TITLE: 2nd Floor
 Designer: Rick Rausch
 Duval County Courthouse
 COMPANY: Longent LLC
 DATE: 1/18/2012

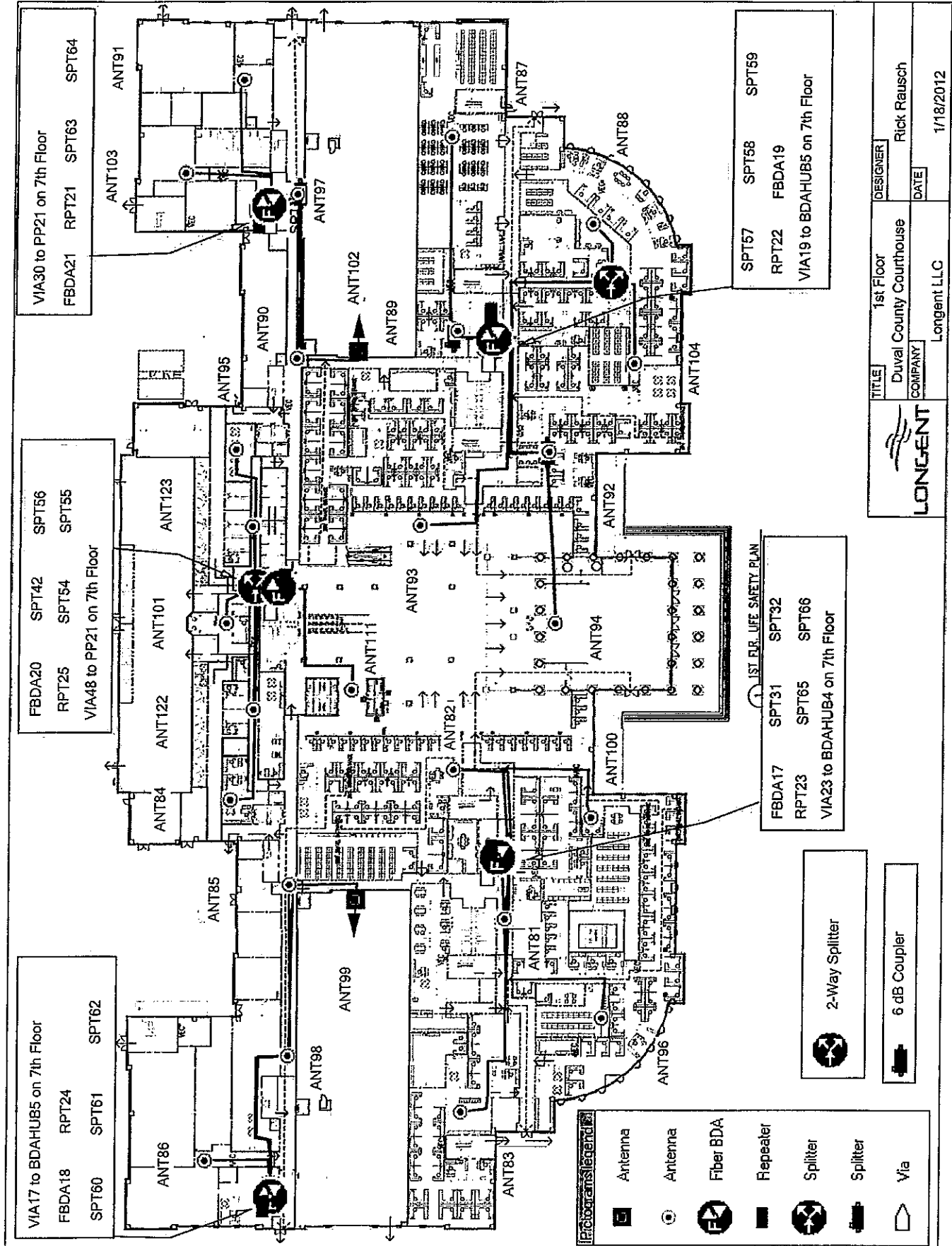

VIA17 to BDAHUB5 on 7th Floor
 FBDA18 RPT24 SPT61 SPT62

FBDA20 SPT42 SPT56
 RPT25 SPT54 SPT55
 VIA48 to PP21 on 7th Floor

VIA30 to PP21 on 7th Floor
 FBDA21 RPT21 SPT63 SPT64

SPT57 SPT58 SPT59
 RPT22 FBDA19
 VIA19 to BDAHUB5 on 7th Floor

FBDA17 SPT31 SPT32
 RPT23 SPT65 SPT66
 VIA23 to BDAHUB4 on 7th Floor

- Legend**
- Antenna
 - Antenna
 - Fiber BDA
 - Repeater
 - Splitter
 - Splitter
 - Via

2-Way Splitter

6 dB Coupler

LONGENT

TITLE: 1st Floor
 Duval County Courthouse
 COMPANY: Longent LLC
 DESIGNER: Rick Rausch
 DATE: 1/18/2012

EXHIBIT B

(The physical space to be used by the Licensee Equipment is shown herein)

Licensee is referred to as "Verizon" or "Verizon Wireless" herein.



VERIZON WIRELESS SITE NAME / GOZER NUMBER
DUVAL COUNTY COURTHOUSE / 102524

INBLD-UJPG

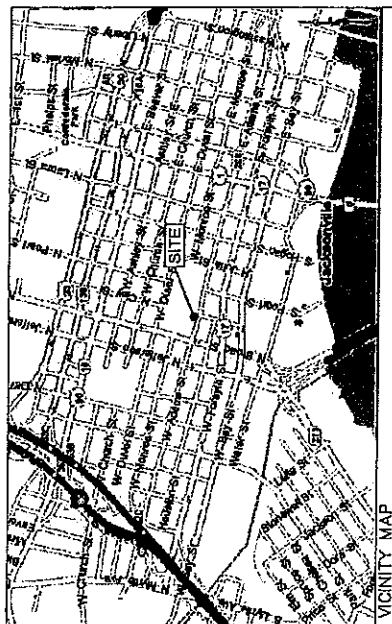

VICINITY MAP

SHEET	DESCRIPTION	REV
T-1	COVER SHEET	0
C-1	GENERAL NOTES	0
C-1	BUILDING SCHEMATIC DIAGRAM	0
C-2	EQUIPMENT ROOM DETAILS	0
C-3	GPS DETAILS	0
C-4	EQUIPMENT PLAN	0
E-1	ELECTRICAL DETAILS	0
E-2	ELECTRICAL DETAILS	0

SHEET INDEX

SITE DATA:
 LATITUDE: 30.19° 47.09' NORTH
 LONGITUDE: 81° 39' 48.83" WEST
 ADDRESS: 301 W ADAMS STREET JACKSONVILLE, FL 32202
 PARCEL ID: 973795-0010
 ZONING DATA: FLORIDA BLDG. CODE 2010 & TIA/BA 222-0-2
 COMPOUND WIND SPEED: 124 MPH (PER FBC 2010)
 SITE WIND SPEED: ULTIMATE NOMINALS
 EXPOSURE CATEGORY: C
 WIND PRESSURE COEFFICIENT: N/A
 COMPONENT & CLADDING WIND PRESSURES: 0/A

PROJECT DATA

FORESITE GROUP
 FORESITE GROUP, INC.
 11111 W. UNIVERSITY BLVD.
 SUITE 2100
 TAMPA, FL 33618
 TEL: 813.281.2529
 FAX: 813.281.2530
 WWW.FORESITEGROUP.COM

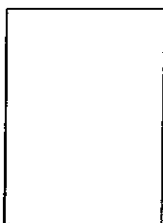

PROJECT: **DUVAL COUNTY COURTHOUSE #102524**
 DEVELOPER: **VERIZON WIRELESS**
 1455 MICROSITE DRIVE
 TAMPA, FL 33627

ISSUED FOR: CONSTRUCTION PERMIT
 PROJECT MANAGER: HOR
 DRAWING BY: K-V
 DATE: 07/28/14
 TITLE:
 REVISIONS: DATE
 COVER SHEET
 SHEET NUMBER: T-1
 JOB/FILE NUMBER: 044-259

VERIZON WIRELESS
 1455 MICROSITE DRIVE STE 600
 TAMPA, FL 33627
CONTACTS



Keep what's below
 Call before you dig
 www.callbeforeyoudig.com

CAUTION
 THIS PROJECT INVOLVES THE USE OF HIGH VOLTAGE ELECTRICAL SYSTEMS. ALL WORK MUST BE DONE IN ACCORDANCE WITH THE NATIONAL ELECTRICAL CODE (NEC) AND ALL APPLICABLE LOCAL, STATE AND FEDERAL REGULATIONS. ALL WORK MUST BE DONE UNDER THE CLOSE SUPERVISION OF A LICENSED ELECTRICIAN. ALL WORK MUST BE DONE IN ACCORDANCE WITH THE PROJECT SPECIFICATIONS AND ALL APPLICABLE LOCAL, STATE AND FEDERAL REGULATIONS.

FOR EMERGENCIES CALL 911

FORESITE GROUP
 11 CA BLDG
 15140 W. GOLF COURSE RD.
 TAMPA, FL 33610

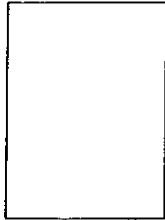

PROJECT: **DUVAL COUNTY COURTHOUSE #102524**
 DATE: 09/29/14

DEVELOPER: **VERIZON WIRELESS**
 1403 SHERWOOD BLVD
 SUITE 200
 TAMPA, FL 33607

REVISIONS	DATE

ISSUED FOR: CONSTRUCTION/PERMIT
 PROJECT MANAGER: HOR
 DRAWING BY: KJV
 DATE: 09/29/14
 TITLE:

BUILDING SCHEMATIC DIAGRAM
 SHEET NUMBER: C-1
 JOB/FILE NUMBER: 044.259

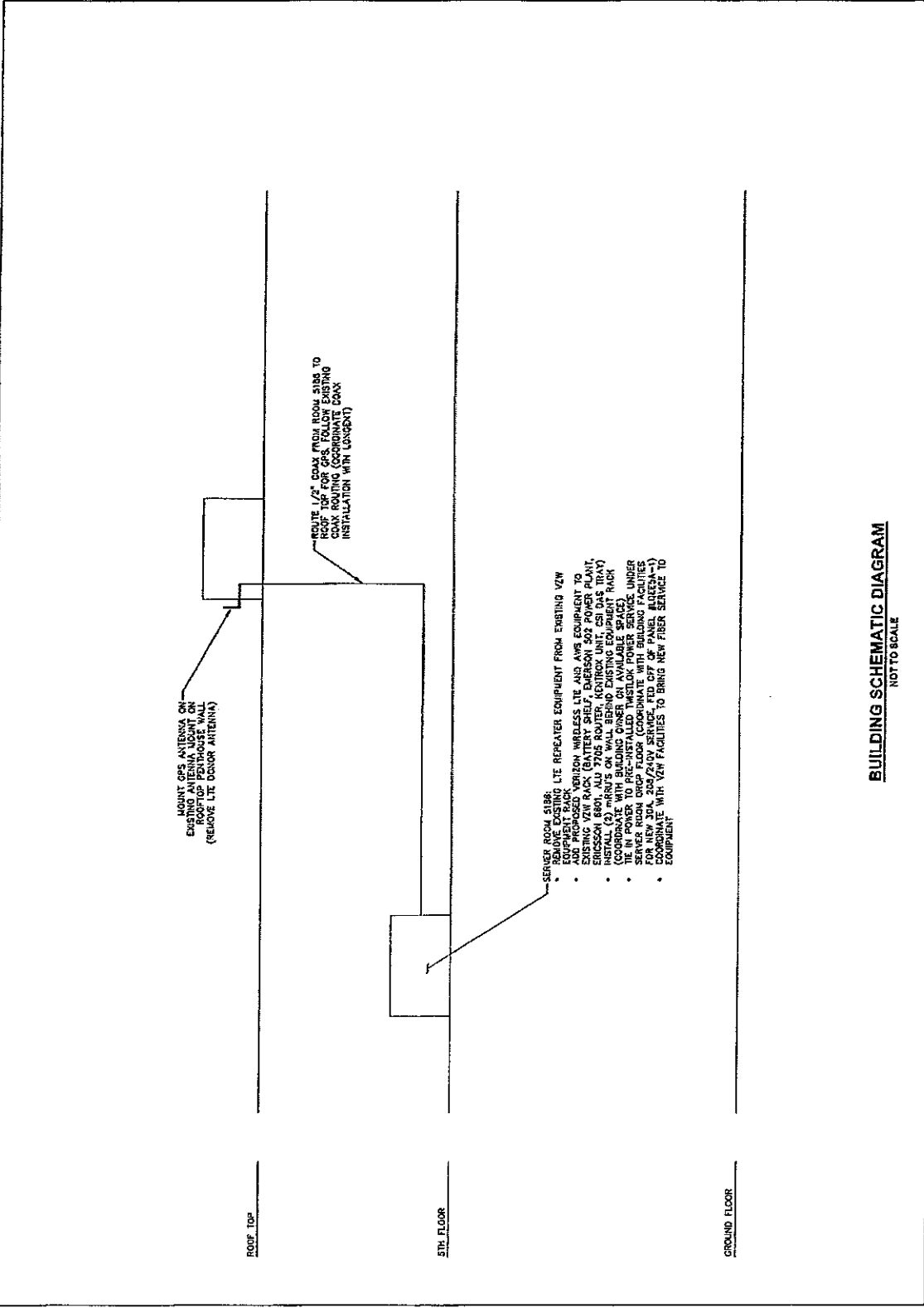

BUILDING SCHEMATIC DIAGRAM
 NOT TO SCALE

FORESITE GROUP
 4000 N. W. 11th St.
 Fort Lauderdale, FL 33304
 Phone: 754.241.1111
 Fax: 754.241.1111
 www.foresite.com

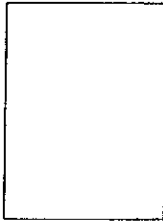

09/29/14

PROJECT:

**DUVAL COUNTY
 COURTHOUSE
 #102524**

DEVELOPER:

VERIZON WIRELESS
 1435 BIRCHWOOD BLVD
 TAMPA, FL 33617

REVISIONS

DATE

ISSUED FOR: CONSTRUCTION/PERMIT
 PROJECT MANAGER: HCR
 DRAWING BY: KJV
 DATE: 09/29/14
 TITLE:

EQUIPMENT ROOM
 DETAILS
 SHEET NUMBER: C-2
 JOB/FILE NUMBER: D-44-259



- SERVER ROOM 318B:
- REMOVE EXISTING LTE REPEATER EQUIPMENT FROM EXISTING VZW EQUIPMENT RACK
 - REMOVE EXISTING VERIZON WIRELESS LIE AND AHS EQUIPMENT TO EXISTING VZW RACK (BATTERY SHELF, EMERSON 502 POWER PLANT, EMERSON 860, ALU 7705 ROUTER, AHS UNIT, CSI D43 TRAY)
 - INSTALL (2) MARR'S ON WALL BEHIND EXISTING EQUIPMENT RACK (COORDINATE WITH BUILDING OWNER ON AVAILABLE SPACE)
 - COORDINATE WITH BUILDING AND VZW FACILITIES TO BRING NEW FIBER SERVICE TO EQUIPMENT

VZW EQUIPMENT RACK (REAR)

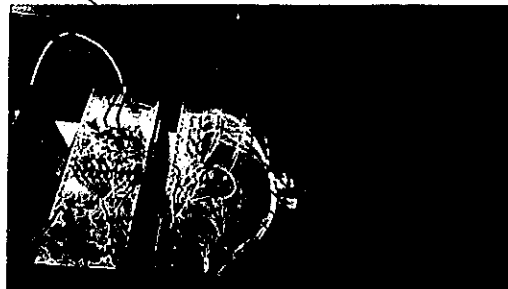

- SERVER ROOM 318B:
- REMOVE EXISTING LTE REPEATER EQUIPMENT FROM EXISTING VZW EQUIPMENT RACK
 - ADD PROPOSED VERIZON WIRELESS LIE AND AHS EQUIPMENT TO EXISTING VZW RACK (BATTERY SHELF, EMERSON 502 POWER PLANT, EMERSON 860, ALU 7705 ROUTER, MARR'S ON WALL, CSI D43 TRAY)
 - INSTALL (2) MARR'S ON WALL BEHIND EXISTING EQUIPMENT RACK (COORDINATE WITH BUILDING OWNER ON AVAILABLE SPACE)
 - COORDINATE WITH BUILDING AND VZW FACILITIES TO BRING NEW FIBER SERVICE TO EQUIPMENT

VZW EQUIPMENT RACK (FRONT)

FORESITE GROUP
 18050 Gulfport Manor Dr. #1101
 Tampa, FL 33618
 Phone: 813-541-3358
 Fax: 813-541-3359
 www.foresitegroup.com

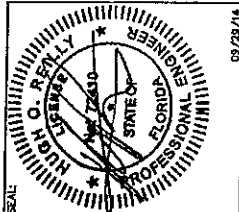
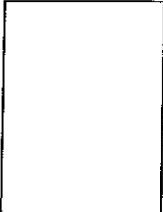

PROJECT: **DUVAL COUNTY COURTHOUSE #102524**
 DEVELOPER: **VERIZON WIRELESS**
 1400 BRENDALE WHITE
 TUSCOLOO, FL 32077

REVISIONS: _____ DATE: _____
 ISSUED FOR: _____
 PROJECT MANAGER: _____
 DRAWING BY: _____
 DATE: 09/29/14
 TITLE: _____

ELECTRICAL DETAILS
 SHEET NUMBER: **E-1**
 037/FILE NUMBER: **044.259**

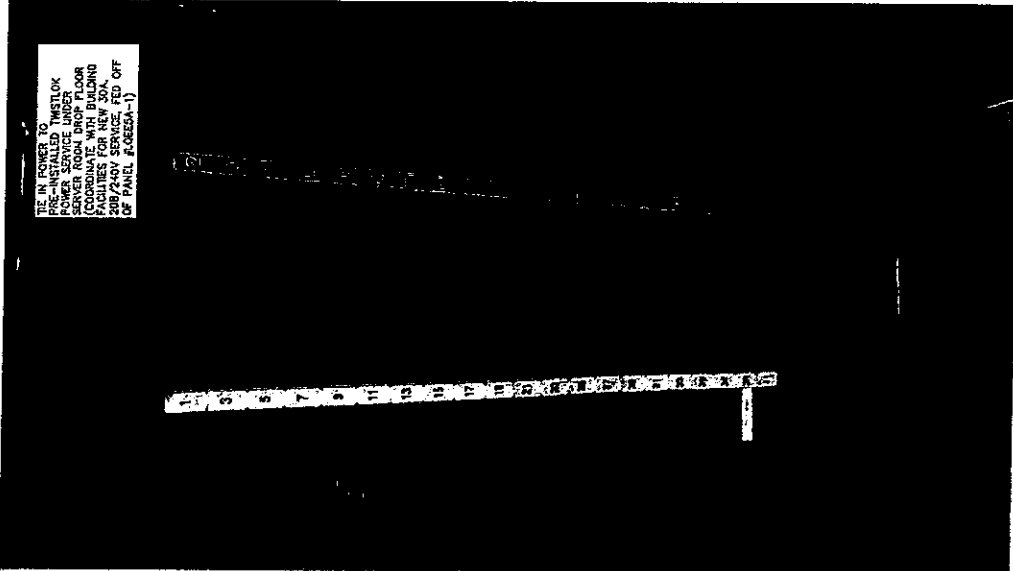

ELECTRICAL PANEL DETAIL

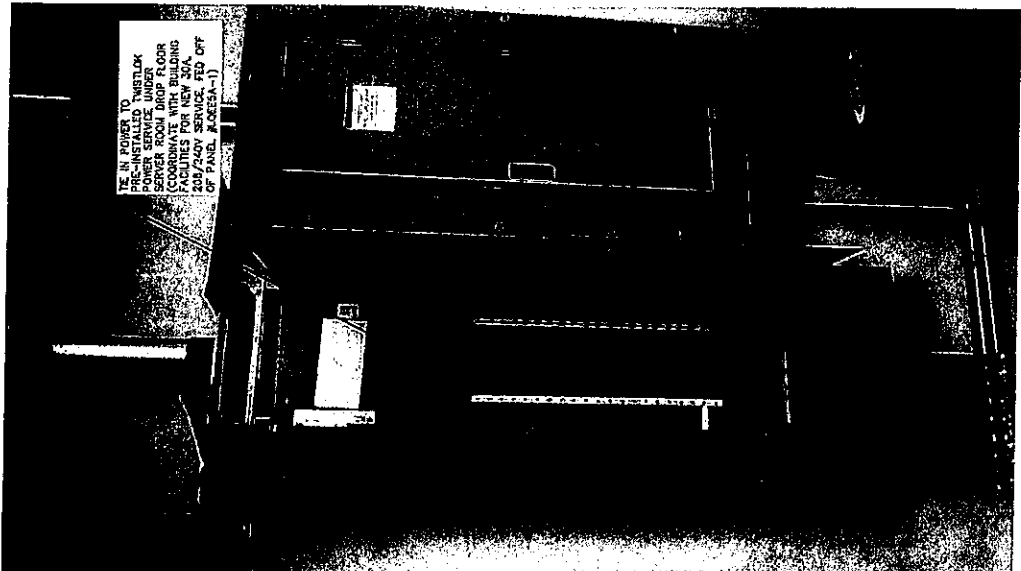

ELECTRICAL PANEL DETAIL

15083

ADMINISTRATIVE AWARD

BID No.: AD-0061-15

AD-0062-15 - MR 12/5/14

DESCRIPTION OF GOODS/SERVICES: Recommend approval for Information Technologies Division to enter into an agreement for IN Building Radio Distribution between Verizon Wireless Personal Communications LP d/b/a Verizon Wireless and the City of Jacksonville. The term of the Agreement shall be five (5) years from date of executed contract with four (4) automatic five (5) year renewal terms. These services are being provided by Verizon Wireless at no cost to the City.

FOR AGENCY/DEPARTMENT: Information Technologies Division

REQUISITION NUMBERS: N/A

NUMBER FIRMS SOLICITED: N/A **NUMBER FIRMS BIDDING:** N/A

REASON FOR LESS THAN REQUIRED MINIMUM SOLICITATION/QUOTATION: N/A

RECOMMEND AWARD TO: Verizon Wireless Personal Communications LP d/b/a Verizon Wireless

CONCURRENCE BY: Usha Mohan, Division Chief/CIO, ITD

PRICE: \$0.00

TERMS: NET 30

REASON FOR NOT ACCEPTING LOW BID: N/A

3



Buyer/Analyst
12/2/14

Date



Mariana Russell
Manager of Purchasing Services
12/4/14

Date

APPROVAL/DISAPPROVAL:

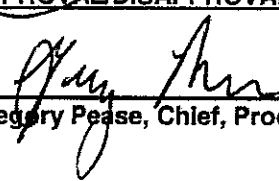

Gregory Pease, Chief, Procurement Division 12/5/14

Date