



Land Development Procedures Manual

VOLUME 3:

Standard Design Details

Effective: January 2025



LAND DEVELOPMENT PROCEDURES MANUAL

VOLUME 3: STANDARD DESIGN DETAILS

CITY OF JACKSONVILLE, FLORIDA

2025

Approved and Adopted in Accordance with
Provisions of Chapter 654, Jacksonville Ordinance Code
(Code of Subdivision Regulations)

Prepared By:

**CDM
Smith**

Effective: January 2025

GENERAL STATEMENT OF LAND DEVELOPMENT PROCEDURES AND CRITERIA

The Land Development Procedures Manual (LDPM) has been produced by the Subdivision Standards and Policy Advisory Committee and the Context Sensitive Streets Standards Committee in conjunction with the Department of Planning and Development, the Department of Public Works, JEA, the Office of General Counsel, and the Private Sector in order to assist in the development of land within the City of Jacksonville. In addition, hereto, certain criteria have been incorporated pursuant to various elements of the 2030 Comprehensive Plan, adopted per Chapter 650 of the Jacksonville Ordinance Code and Chapter 163, Part II, Florida Statutes.

The LDPM includes four volumes as outlined below which are adopted and approved as provided in Chapter 654 of the Jacksonville Ordinance Code to be used by the Divisions within the Department of Planning and Development, the Engineering Division of the Department of Public Works, and JEA in review and approval of permit applications and site development plans.

VOLUME 1: Land Development Review and Approval Procedures

VOLUME 2: Design Guidelines

VOLUME 3: Standard Design Details

VOLUME 4: Standard Specifications

The information contained in the LDPM Volumes 1 through 4 will apply to all development and construction projects, both public and private, within the jurisdiction of the Department of Planning and Development of the City of Jacksonville.

DEPARTMENT OF PUBLIC WORKS
ENGINEERING DIVISION
ROADWAY STANDARD SECTION
INDEX

Series 100 ROADWAYS

- P-108 Flexible Pavement Design for Design Classification Groups P&Q
- P-109 Rigid Pavement
- P-110 Rigid Pavement Joint Details
- P-111 Standard Cul-De-Sac with Curb & Gutter
- P-112 Standard Cul-De-Sac with Swale
- P-113 Special "T" Turnaround
- P-114 Bicycle Facility Typical Standards
- P-115 Vacant
- P-116 Vacant
- P-117 Vacant
- P-118 Vacant
- P-119 Design Classification A Thoroughfare
- P-120 Design Classification B/C Boulevard
- P-121 Vacant
- P-122 Design Classification D/G Avenue
- P-123 Vacant
- P-124 Design Classification E/H Limited Avenue
- P-125 Design Classification J/N Neighborhood Commercial Street
- P-126 Design Classification L/P Neighborhood Residential Street
- P-127 Design Classification Q Residential Local Subdivision
- P-128 Design Classification F/I/M Industrial
- P-129 Design Classification K/O Business Park
- P-130 Street Classification R Alley

Series 200 PRIVATE D/W AND ROADWAYS

- P-201 Private Road Driveway Entrances
- P-202 Inverted Crown Private Drive
- P-203 Private Drive with Parking
- P-204 Standard Asphaltic Concrete Driveway
- P-205 Standard & Optical Flared Concrete Driveway Detail
- P-206 Optional Flared Commercial Concrete Driveway Details

Series 300 CURB & GUTTER AND HANDICAP

- P-301 City Standard Curb Templates
- P-302 Curb Cut Ramp Facility for Physically Handicapped City Standard Curb & Gutter
- P-303 Curb Cut Ramp Facility for Physically Handicapped Miami Curb & Gutter
- P-304 Curb Cut Ramp Facility for Physically Handicapped
- P-305 Curb Cut Ramp Facility for Physically Handicapped
- P-306 Handicap Parking Detail

Series 400 PAVEMENT REPAIRS

- P-401 Standard Paving Manhole Adjustments
- P-402 Case I Standard Paving Repair Detail
- P-403 Case II Standard Paving Repair Detail
- P-404 Case III Standard Paving Repair Detail
- P-405 Case IV Standard Paving Repair Detail
- P-406 Case V Standard Paving Repair Detail
- P-407 Case VI & VII Standard Paving Repair Detail
- P-408 Case IX Standard Paving Repair Detail
- P-409 Case X Standard Paving Repair Detail
- P-410 Case XI Standard Paving Repair Detail
- P-411 Case XII Standard Brick Street Repair Detail
- P-412 Case XIII Standard Brick Street Repair Detail
- P-413 Case XIV Standard Brick Street Repair Detail

Series 500 TRADITIONAL NEIGHBORHOOD UTILITY LOCATION

- P-501 Vacant
- P-502 Vacant
- P-503 Vacant
- P-504 Vacant
- P-505 Vacant
- P-506 TND Alley

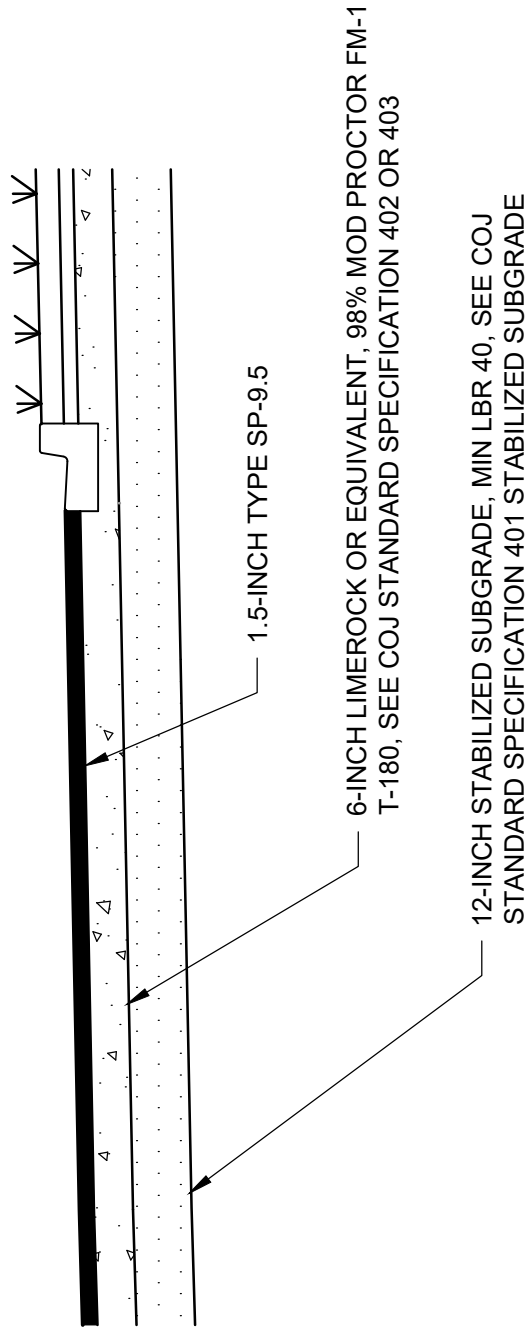

NOTES:

1. A TWO-LIFT ASPHALT COURSE IS REQUIRED FOR ALL NEW ROADWAYS. THE TWO-LIFT REQUIREMENT SHALL INCLUDE A FIRST ASPHALT COURSE (FIRST LIFT) AND A FINAL ASPHALT SURFACE (SECOND LIFT) APPLIED IN 1 INCH MINIMUM THICKNESSES. A TRACK COAT SHALL BE REQUIRED BETWEEN EACH LIFT OF ASPHALT.
2. ALL DISTURBED AREAS SHALL BE SEEDED & MULCHED. ALL AREAS WHERE SOD HAS BEEN DISTURBED OR REMOVED SHALL BE RESODDED TO SATISFACTION OF OWNER.

FLEXIBLE PAVEMENT DESIGN
FOR DESIGN CLASSIFICATION
GROUPS P&Q

CITY OF
JACKSONVILLE
STANDARD

N.T.S.

PLATE P-108

DATE DRAWN 03-21-89

REVISED DATE 12-06-24

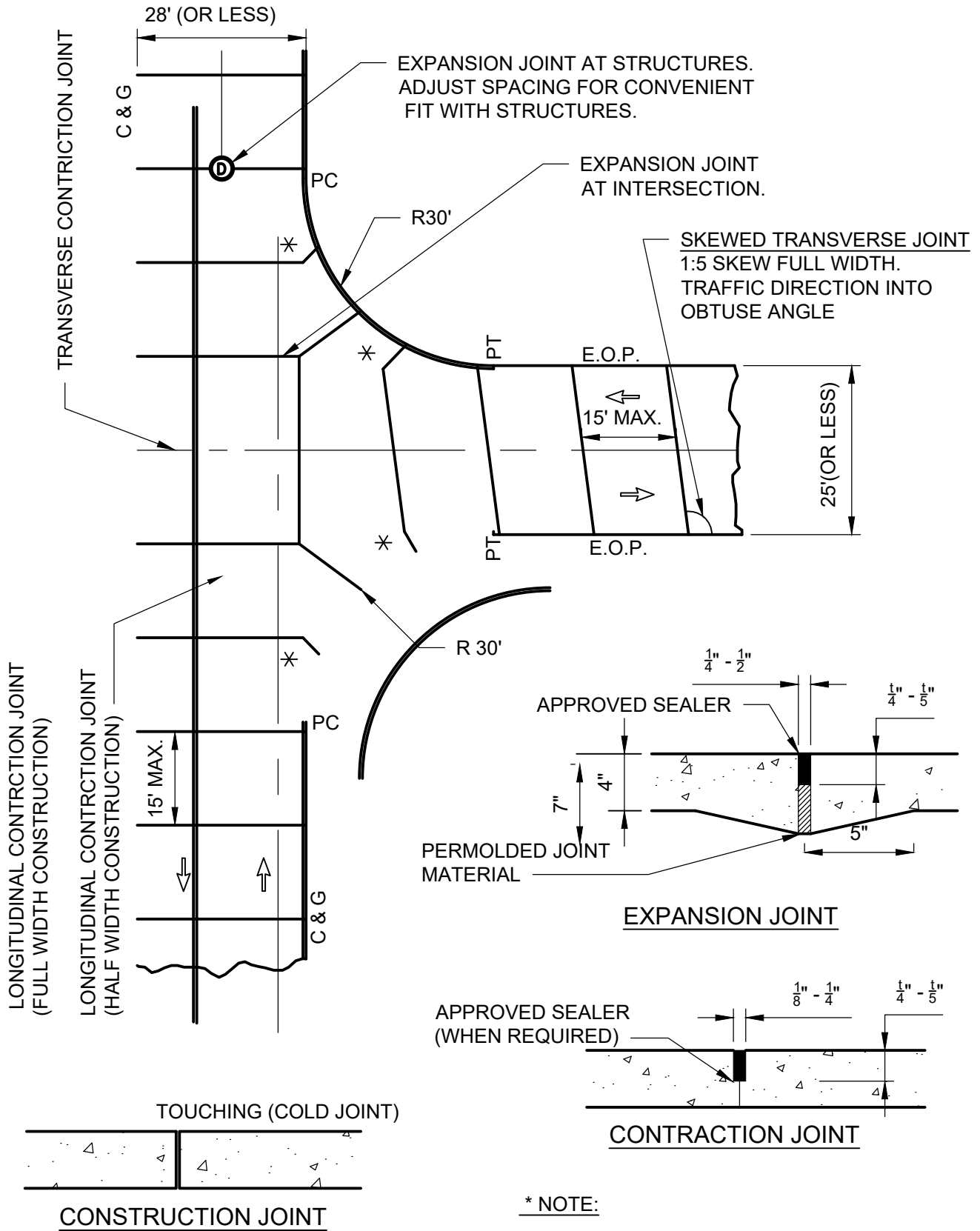

RIGID PAVEMENT JOINT
DETAILS

CITY OF
JACKSONVILLE
STANDARD

N.T.S.

PLATE P-110

DATE DRAWN

8-3-79

REVISED DATE

12-06-24

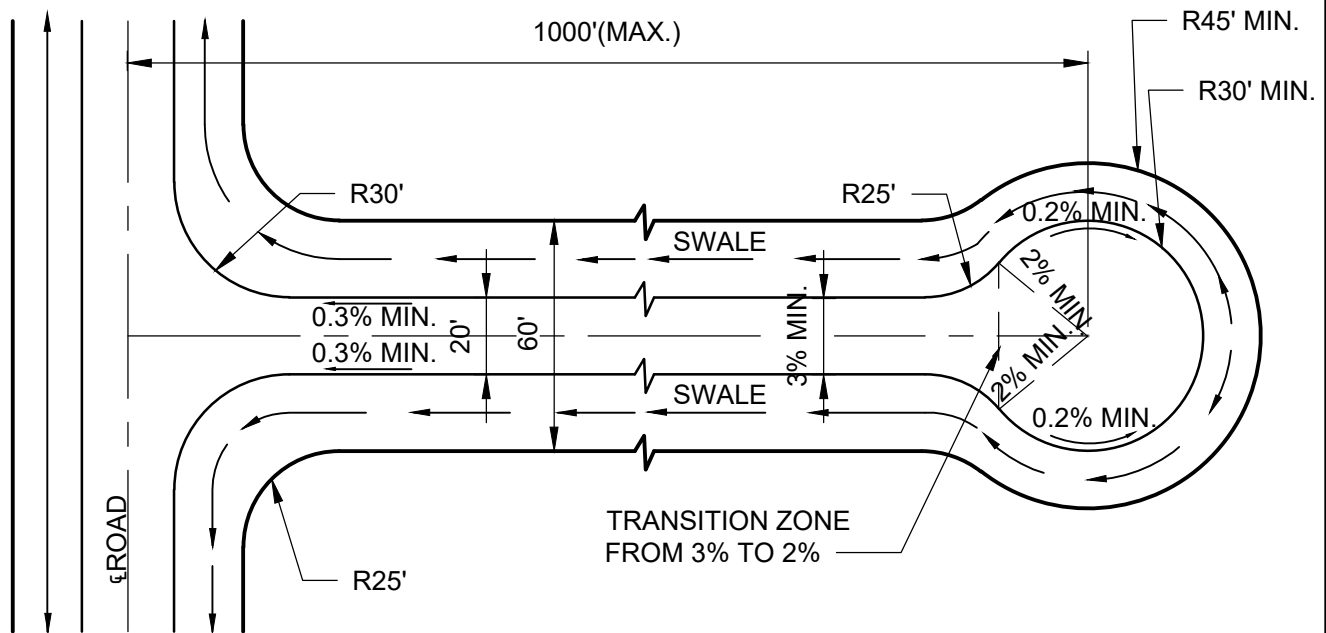
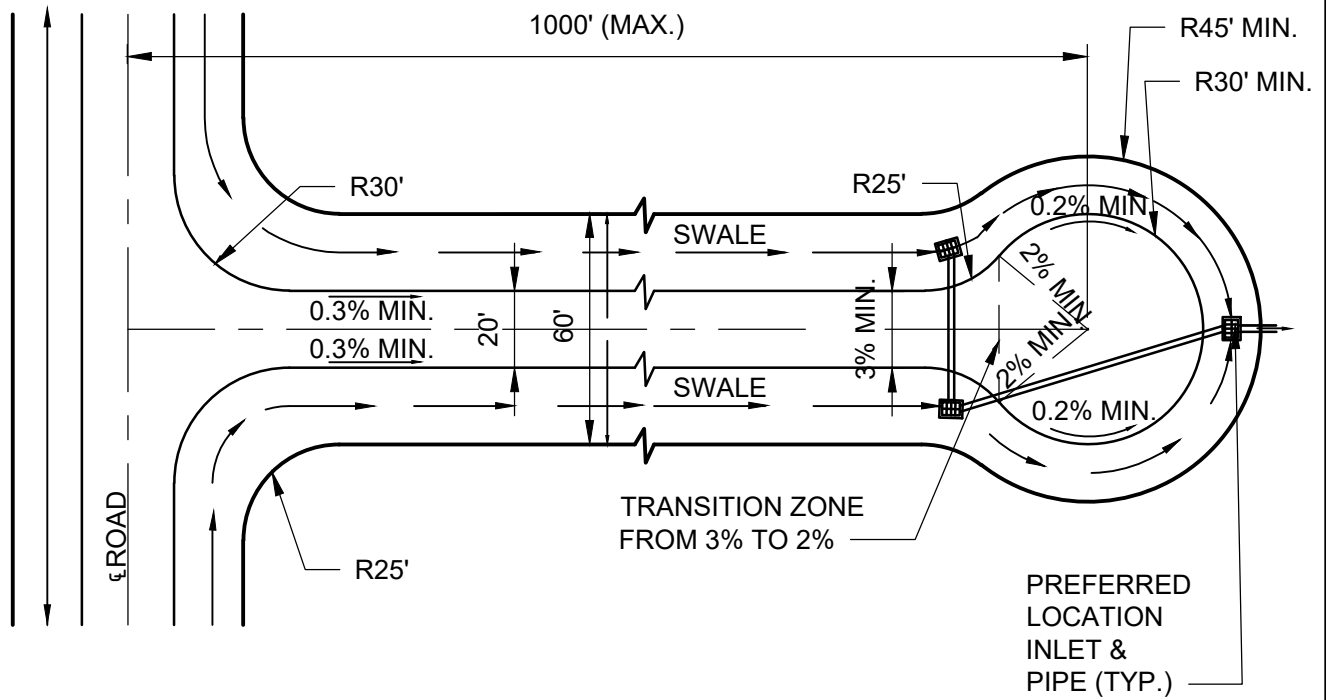

GENERAL NOTES:

1. SWALE SLOPE DEPENDS ON VELOCITY: MAX. 2 f.p.s.
2. PAVING SHALL BE CROWNED MIN. OF 3% TO PROVIDE ADEQUATE RUN-OFF OFF STREET PAVEMENT.
3. PAVING SHALL BE CROWNED MIN. OF 2% TO PROVIDE ADEQUATE RUN-OFF OFF CUL-DE-SAC PAVEMENT.
4. VALLEY GUTTERS ARE NOT ALLOWED.
5. INLETS & PIPES TO BE LOCATED AS NECESSARY.

STANDARD CUL-DE-SAC
WITH SWALE

CITY OF
JACKSONVILLE
STANDARD

N.T.S.

PLATE P-112

DATE DRAWN 03-23-89

REVISED DATE 12-06-24

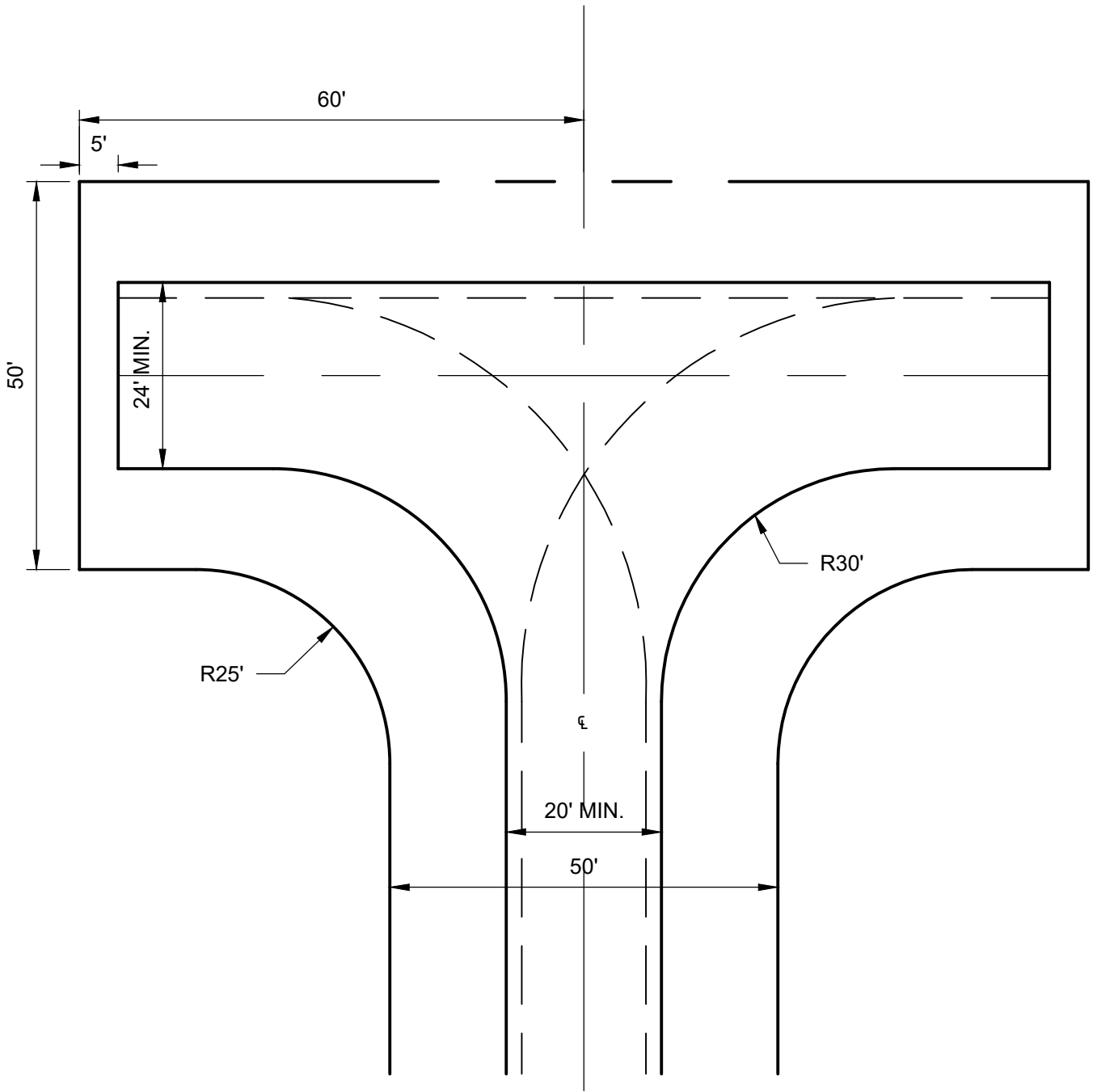

SYMMETRICAL ABOUT CL

KEY: PATH OF RIGHT FRONT WHEEL
(S.U. DESIGN VEHICLE-AASHTO, A
POLICY ON GEOMETRIC DESIGN)

NOTE:
TO BE USED ONLY WHERE
CUL-DE-SAC IS INAPPROPRIATE

SPECIAL "T" TURNAROUND	CITY OF JACKSONVILLE STANDARD	N.T.S.	PLATE P-113
		DATE DRAWN	5-24-89
		REVISED DATE	12-06-24

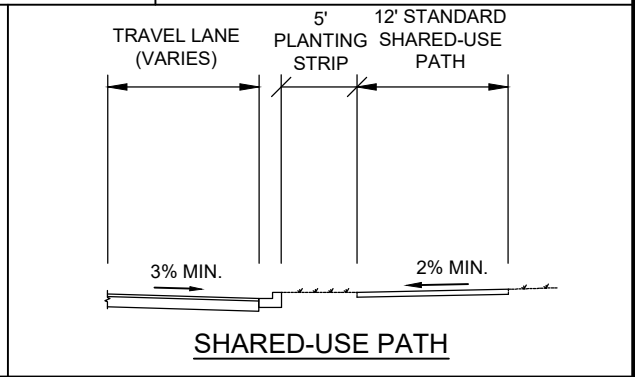
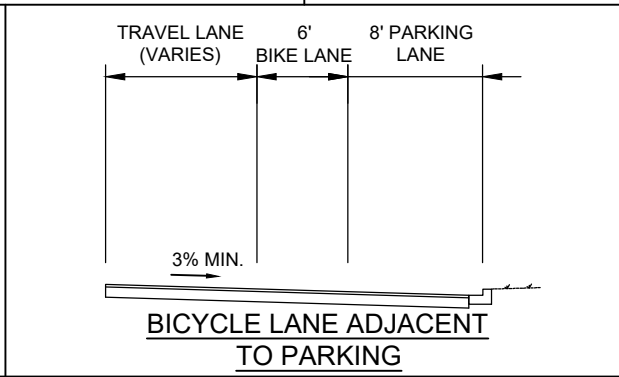
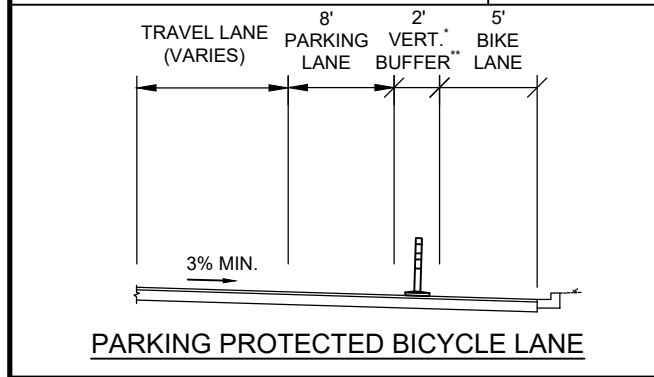
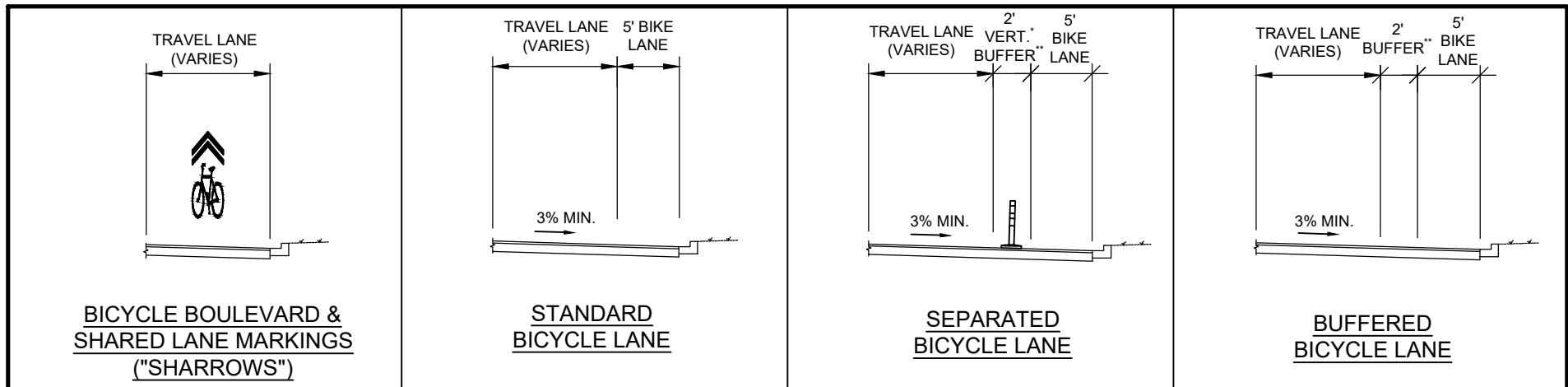

1. PAVEMENT MARKINGS AND SIGNAGE SHALL CONFORM WITH CURRENT FDOT DESIGN MANUAL AND CURRENT FHWA-MANUAL ON UNIFORM TRAFFIC CONTROL DEVICES.
 2. REFER TO SECTION 3.0 OF THE LAND DEVELOPMENT PROCEDURES MANUAL FOR ADDITIONAL DETAILS.
 3. BIKE LANES AND TRAVEL LANES ARE MEASURED TO THE EDGE OF PAVEMENT.
 4. PARKING LANES ARE MEASURED TO THE FACE OF CURB.
- * VERTICAL BUFFER CAN BE MADE OF VARIOUS MATERIALS, INCLUDING: CONCRETE, PLANTERS, SOFT-HIT POSTS AND BOLLARDS.
- ** BUFFER AREA SHALL HAVE INTERIOR DIAGONAL CROSS HATCHING.

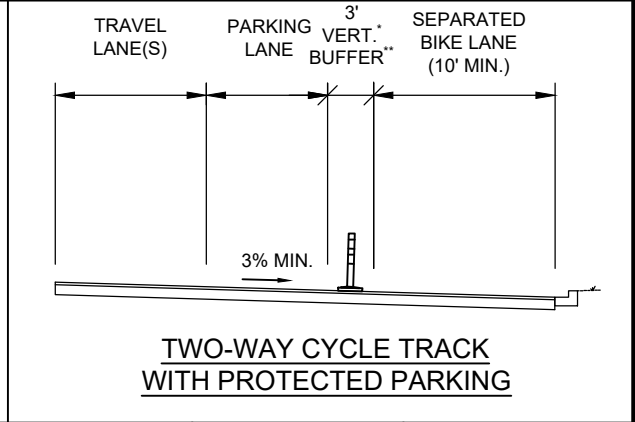
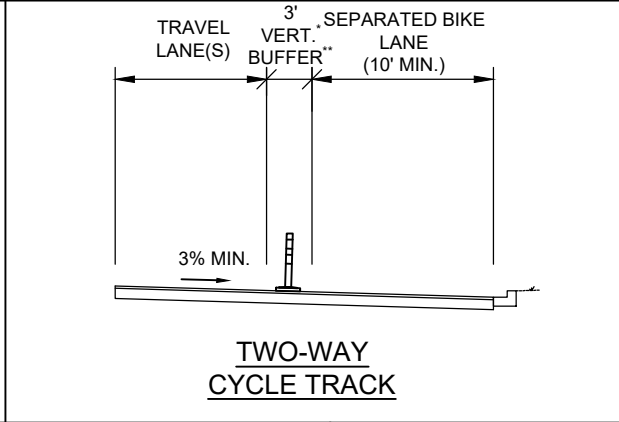

CITY OF JACKSONVILLE STANDARD	BICYCLE FACILITY TYPICAL STANDARDS	N.T.S.	PLATE P-114
		DATE DRAWN 1-31-17	
		REVISED DATE 11-22-24	

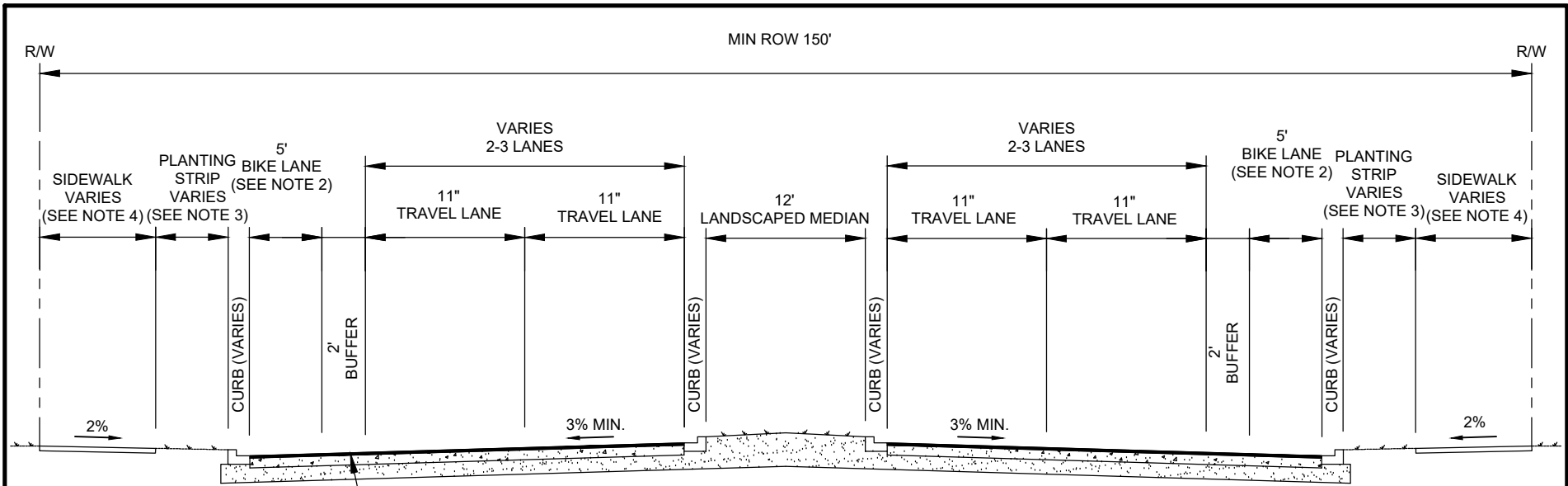

BUFFER AREA SHALL HAVE INTERIOR DIAGONAL CROSS HATCHING

NOTES:

1. ALL DISTURBED AREAS SHALL BE SEEDED & MULCHED. ALL AREAS WHERE SOD HAS BEEN DISTURBED OR REMOVED SHALL BE RESODDED.
2. SEE LAND DEVELOPMENT PROCEDURES MANUAL, VOLUME 2, SECTION 2.4 FOR BICYCLE FACILITY DESIGN REQUIREMENTS AND BIKE FACILITY PREFERENCES.
3. PLANTING STRIP TO HAVE A DESIRED MINIMUM OF 5' WIDTH. 8' IS DESIRED IF STREET TREES ARE INCLUDED.
4. SEE LAND DEVELOPMENT PROCEDURES MANUAL, VOLUME 2, TABLE 2.2-1 FOR SIDEWALK DESIGN REQUIREMENTS. SIDEWALKS MUST START WITHIN 12" OF THE ROW LINE.
5. SEE LAND DEVELOPMENT PROCEDURES MANUAL, VOLUME 2, SECTION 2.3 FOR PAVEMENT DESIGN REQUIREMENTS.

	CITY OF JACKSONVILLE STANDARD	DESIGN CLASSIFICATION A THOROUGHFARE	N.T.S.	PLATE P-119
			DATE DRAWN	1-31-17
			REVISED DATE	11-22-24

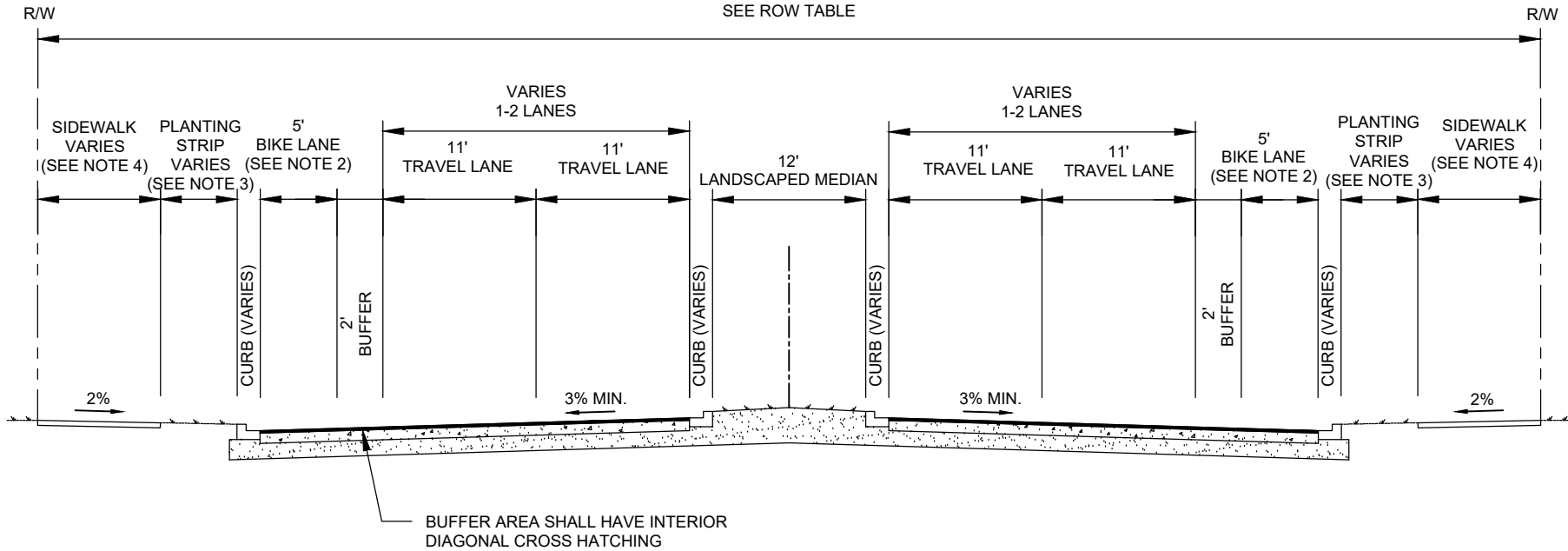

NOTES:

1. ALL DISTURBED AREAS SHALL BE SEEDED & MULCHED. ALL AREAS WHERE SOD HAS BEEN DISTURBED OR REMOVED SHALL BE RESODDED.
2. SEE LAND DEVELOPMENT PROCEDURES MANUAL, VOLUME 2, SECTION 2.4 FOR BICYCLE FACILITY DESIGN REQUIREMENTS AND BIKE FACILITY PREFERENCES.
3. PLANTING STRIP TO HAVE A DESIRED MINIMUM OF 5' WIDTH. 8' IS DESIRED IF STREET TREES ARE INCLUDED.
4. SEE LAND DEVELOPMENT PROCEDURES MANUAL, VOLUME 2, TABLE 2.2-1 FOR SIDEWALK DESIGN REQUIREMENTS. SIDEWALKS MUST START WITHIN 12" OF THE ROW LINE.
5. SEE LAND DEVELOPMENT PROCEDURES MANUAL, VOLUME 2, SECTION 2.3 FOR PAVEMENT DESIGN REQUIREMENTS.

FUNCTIONAL HIGHWAY CLASSIFICATION	ROADWAY DESIGN MATRIX	DEVELOPMENT AREA	TYPICAL NUMBER OF TRAVEL LANES	MINIMUM ROW (FT)
MAJOR ARTERIAL	B	ALL	5	150
MINOR ARTERIAL	C	ALL	4	120

**CITY OF JACKSONVILLE
STANDARD**

**DESIGN CLASSIFICATION B/C
BOULEVARD**

N.T.S.

PLATE P-120

DATE DRAWN 1-31-17

REVISED DATE 11-22-24

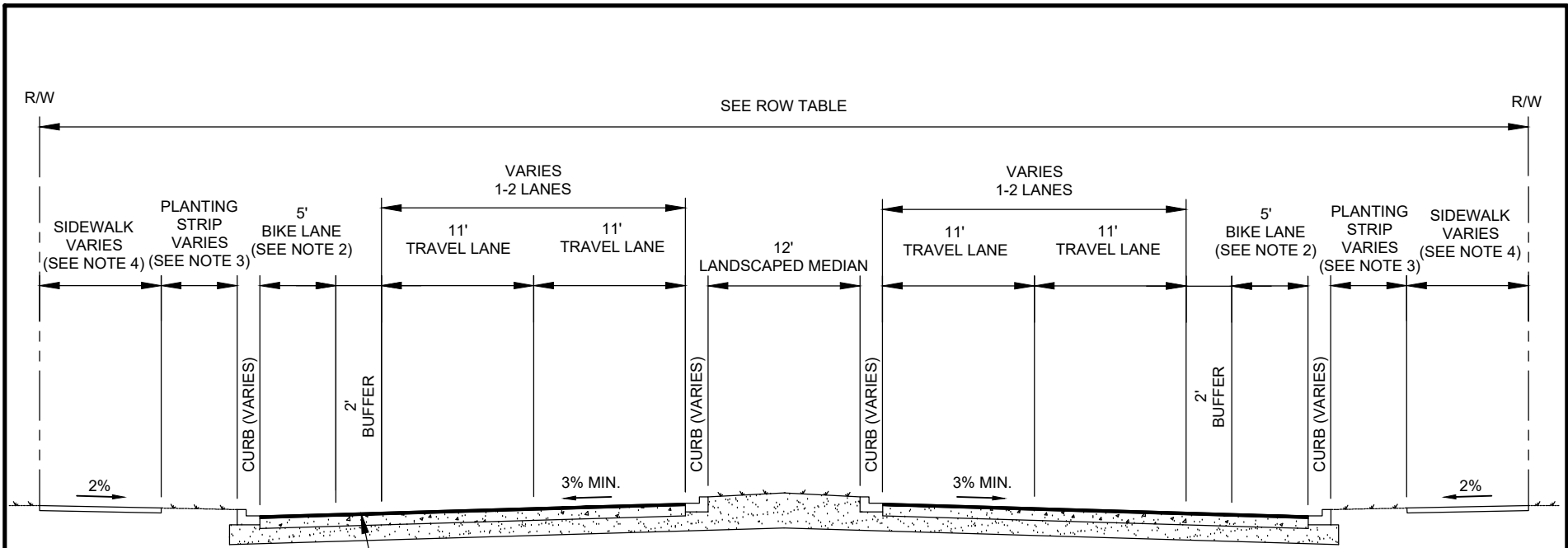

BUFFER AREA SHALL HAVE INTERIOR DIAGONAL CROSS HATCHING

NOTES:

1. ALL DISTURBED AREAS SHALL BE SEEDED & MULCHED. ALL AREAS WHERE SOD HAS BEEN DISTURBED OR REMOVED SHALL BE RESODDED.
2. SEE LAND DEVELOPMENT PROCEDURES MANUAL, VOLUME 2, SECTION 2.4 FOR BICYCLE FACILITY DESIGN REQUIREMENTS AND BIKE FACILITY PREFERENCES.
3. PLANTING STRIP TO HAVE A DESIRED MINIMUM OF 5' WIDTH. 8' IS DESIRED IF STREET TREES ARE INCLUDED.
4. SEE LAND DEVELOPMENT PROCEDURES MANUAL, VOLUME 2, TABLE 2.2-1 FOR SIDEWALK DESIGN REQUIREMENTS. SIDEWALKS MUST START WITHIN 12" OF THE ROW LINE.
5. SEE LAND DEVELOPMENT PROCEDURES MANUAL, VOLUME 2, SECTION 2.3 FOR PAVEMENT DESIGN REQUIREMENTS

FUNCTIONAL HIGHWAY CLASSIFICATION	ROADWAY DESIGN MATRIX	DEVELOPMENT AREA	TYPICAL NUMBER OF TRAVEL LANES	MINIMUM ROW (FT)
MINOR ARTERIAL	D	ALL	4	120
COLLECTOR	G	DOWNTOWN, URBAN, URBAN PRIORITY, SUBURBAN	2	80
		RURAL		100

CITY OF JACKSONVILLE STANDARD	DESIGN CLASSIFICATION D/G AVENUE	N.T.S.	PLATE P-122
		DATE DRAWN	1-31-17
		REVISED DATE	11-22-24

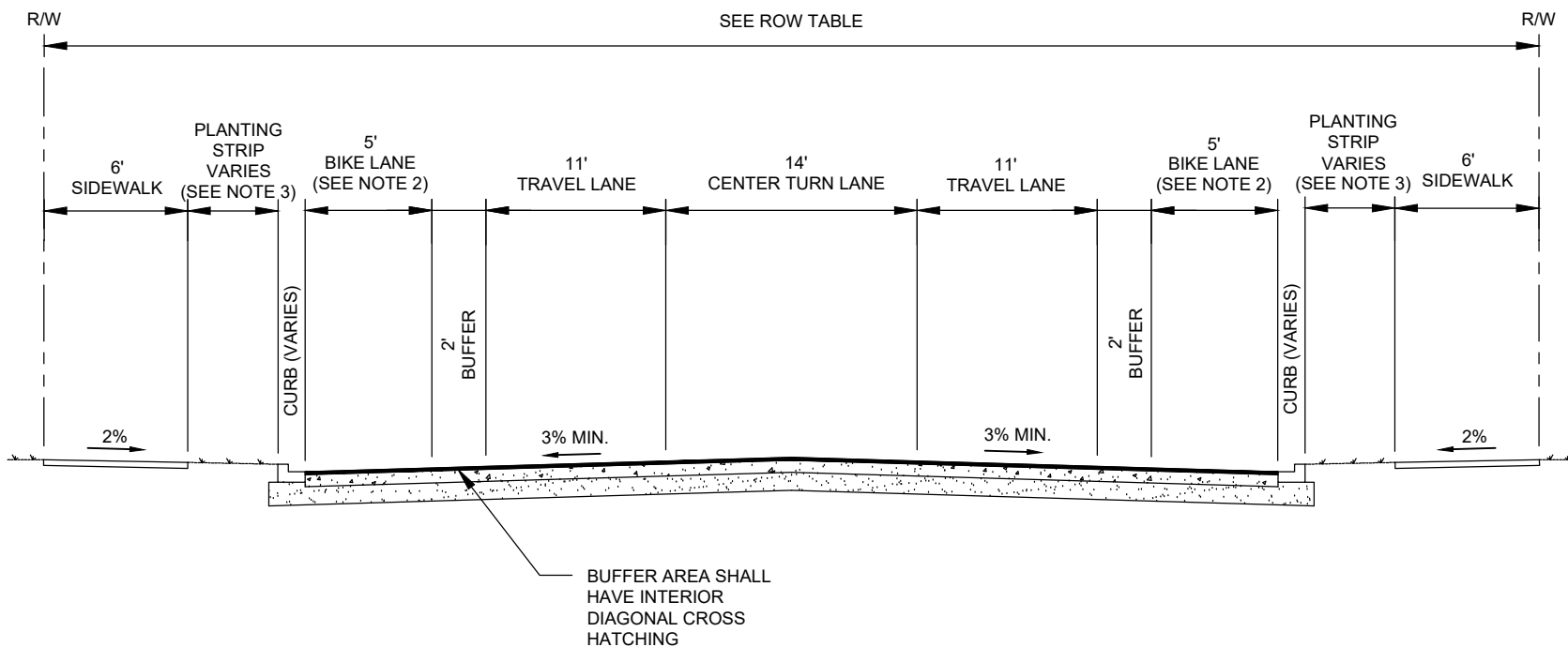

NOTES:

1. ALL DISTURBED AREAS SHALL BE SEEDED & MULCHED. ALL AREAS WHERE SOD HAS BEEN DISTURBED OR REMOVED SHALL BE RESODDED.
2. SEE LAND DEVELOPMENT PROCEDURES MANUAL, VOLUME 2, SECTION 2.4 FOR BICYCLE FACILITY DESIGN REQUIREMENTS AND BIKE FACILITY PREFERENCES.
3. PLANTING STRIP TO HAVE A MINIMUM 5' WIDTH. 8' IS DESIRED IF STREET TREES ARE INCLUDED.
4. SEE LAND DEVELOPMENT PROCEDURES MANUAL, VOLUME 2, TABLE 2.2-1 FOR SIDEWALK DESIGN REQUIREMENTS. SIDEWALKS MUST START WITHIN 12" OF THE ROW LINE.
5. SEE LAND DEVELOPMENT PROCEDURES MANUAL, VOLUME 2, SECTION 2.3 FOR PAVEMENT DESIGN REQUIREMENTS.

FUNCTIONAL HIGHWAY CLASSIFICATION	ROADWAY DESIGN MATRIX	DEVELOPMENT AREA	TYPICAL NUMBER OF TRAVEL LANES	MINIMUM ROW (FT)
MINOR ARTERIAL	E	ALL	5	120
COLLECTOR	H	DOWNTOWN, URBAN, URBAN PRIORITY, SUBURBAN	3	80
		RURAL		100

**CITY OF JACKSONVILLE
STANDARD**

DESIGN CLASSIFICATION E/H
LIMITED AVENUE

N.T.S.

PLATE P-124

DATE DRAWN 9-9-20

REVISED DATE 11-22-24

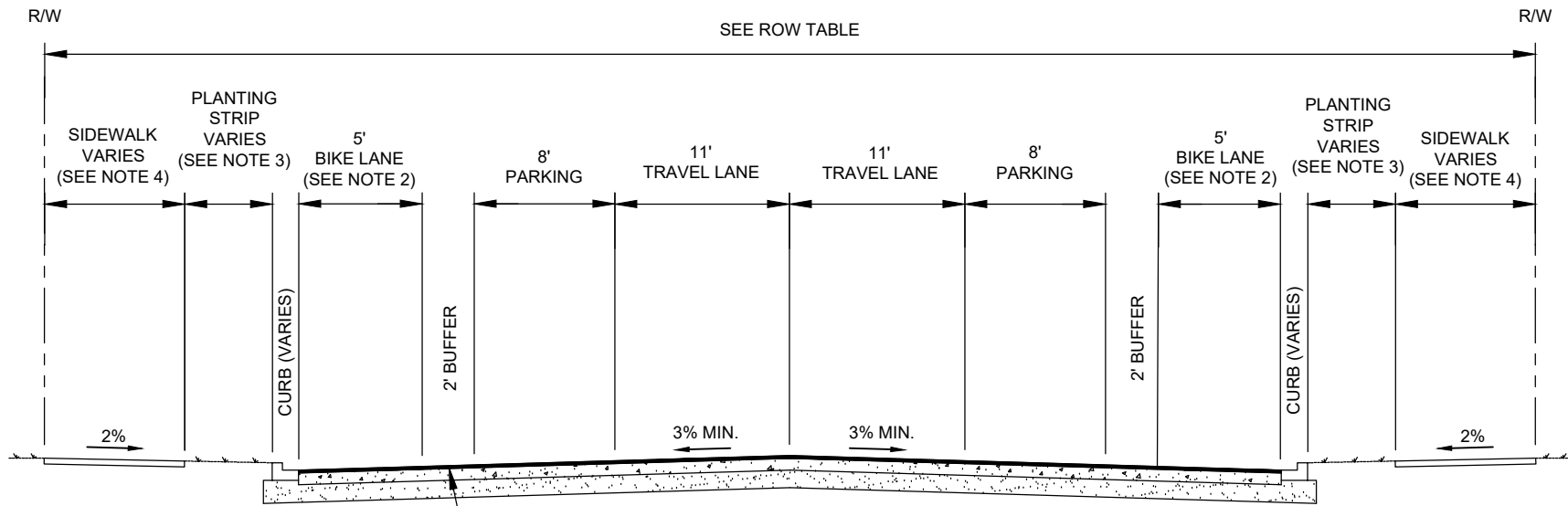

BUFFER AREA SHALL HAVE INTERIOR DIAGONAL CROSS HATCHING

NOTES:

1. ALL DISTURBED AREAS SHALL BE SEEDED & MULCHED. ALL AREAS WHERE SOD HAS BEEN DISTURBED OR REMOVED SHALL BE RESODDED.
2. SEE LAND DEVELOPMENT PROCEDURES MANUAL, VOLUME 2, SECTION 2.4 FOR BICYCLE FACILITY DESIGN REQUIREMENTS AND BIKE FACILITY PREFERENCES.
3. PLANTING STRIP TO HAVE A MINIMUM 5' WIDTH. 8' IS DESIRED IF STREET TREES ARE INCLUDED.
4. SEE LAND DEVELOPMENT PROCEDURES MANUAL, VOLUME 2, TABLE 2.2-1 FOR SIDEWALK DESIGN REQUIREMENTS. SIDEWALKS MUST START WITHIN 12" OF THE ROW LINE.
5. SEE LAND DEVELOPMENT PROCEDURES MANUAL, VOLUME 2, SECTION 2.3 FOR PAVEMENT DESIGN REQUIREMENTS.

FUNCTIONAL HIGHWAY CLASSIFICATION	ROADWAY DESIGN MATRIX	DEVELOPMENT AREA	TYPICAL NUMBER OF TRAVEL LANES	MINIMUM ROW (FT)
COLLECTOR	J	DOWNTOWN, URBAN, URBAN PRIORITY, SUBURBAN	3	100
		RURAL		120
LOCAL	N	DOWNTOWN, URBAN, URBAN PRIORITY, SUBURBAN	2	80
		RURAL		100

CITY OF JACKSONVILLE STANDARD	DESIGN CLASSIFICATION J/N NEIGHBORHOOD COMMERCIAL STREET	N.T.S.	PLATE P-125
		DATE DRAWN	1-31-17
		REVISED DATE	11-22-24

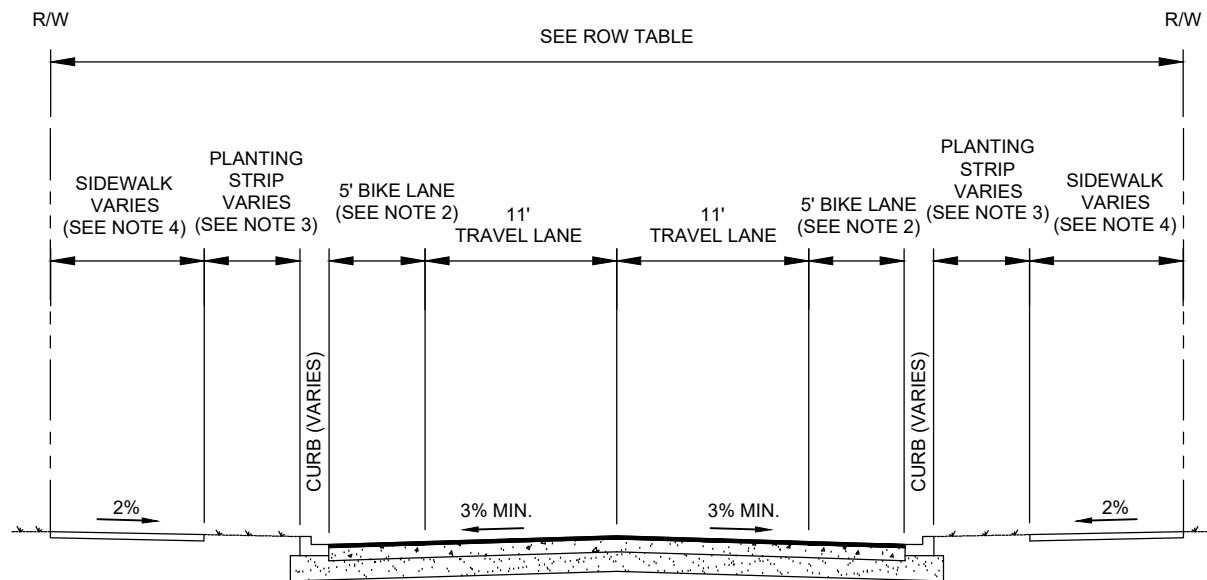

NOTES:

1. ALL DISTURBED AREAS SHALL BE SEEDED & MULCHED. ALL AREAS WHERE SOD HAS BEEN DISTURBED OR REMOVED SHALL BE RESODDED.
2. SEE LAND DEVELOPMENT PROCEDURES MANUAL, VOLUME 2, SECTION 2.4 FOR BICYCLE FACILITY DESIGN REQUIREMENTS AND BIKE FACILITY PREFERENCES.
3. PLANTING STRIP TO HAVE A MINIMUM 5' WIDTH. 8' IS DESIRED IF STREET TREES ARE INCLUDED.
4. SEE LAND DEVELOPMENT PROCEDURES MANUAL, VOLUME 2, TABLE 2.2-1 FOR SIDEWALK DESIGN REQUIREMENTS. SIDEWALKS MUST START WITHIN 12" OF THE ROW LINE.
5. SEE LAND DEVELOPMENT PROCEDURES MANUAL, VOLUME 2, SECTION 2.3 FOR PAVEMENT DESIGN REQUIREMENTS.

FUNCTIONAL HIGHWAY CLASSIFICATION	ROADWAY DESIGN MATRIX	DEVELOPMENT AREA	TYPICAL NUMBER OF TRAVEL LANES	MINIMUM ROW (FT)
COLLECTOR	L	DOWNTOWN, URBAN, URBAN PRIORITY, SUBURBAN	3	80
		RURAL		100
LOCAL	P	DOWNTOWN, URBAN, URBAN PRIORITY, SUBURBAN	2	60
		RURAL		80

**CITY OF JACKSONVILLE
STANDARD**

**DESIGN CLASSIFICATION L/P
NEIGHBORHOOD
RESIDENTIAL STREET**

N.T.S.

PLATE P-126

DATE DRAWN 1-31-17

REVISED DATE 11-22-24

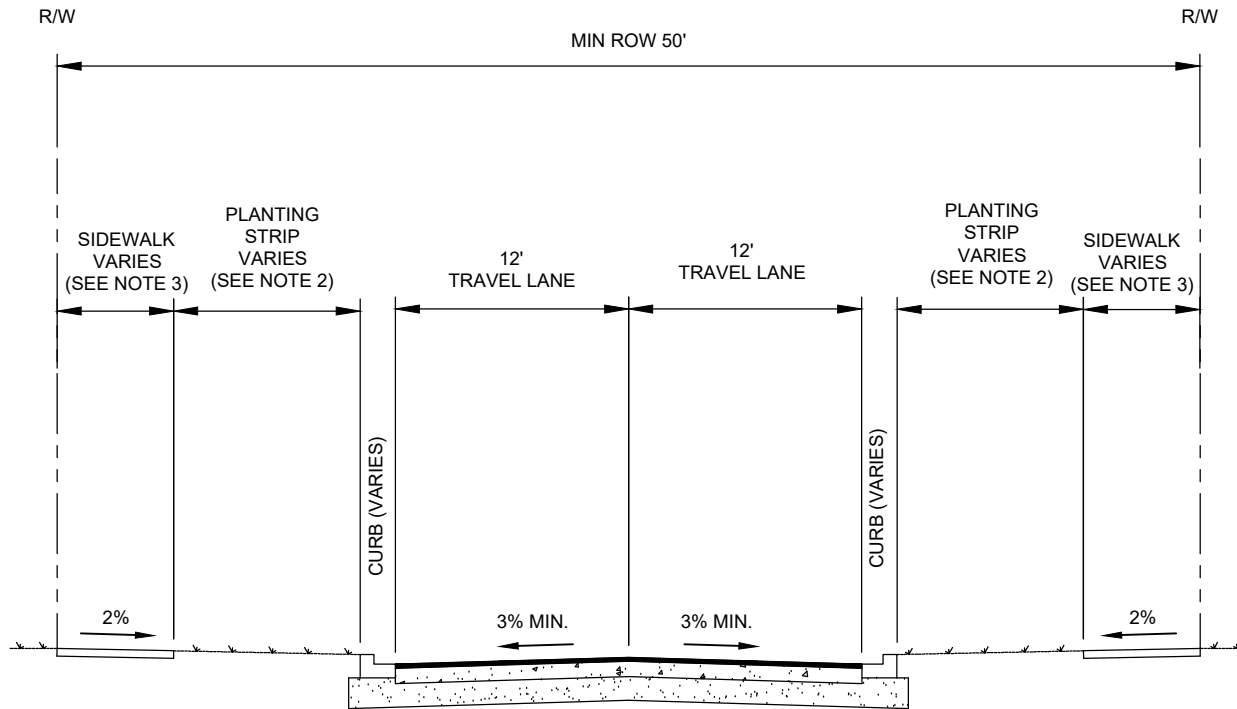

NOTES:

1. ALL DISTURBED AREAS SHALL BE SEEDED & MULCHED. ALL AREAS WHERE SOD HAS BEEN DISTURBED OR REMOVED SHALL BE RESODDED.
2. PLANTING STRIP TO HAVE A DESIRED MINIMUM OF 5' WIDTH. 8' IS DESIRED IF STREET TREES ARE INCLUDED.
3. SEE LAND DEVELOPMENT PROCEDURES MANUAL, VOLUME 2, TABLE 2.2-1 FOR SIDEWALK DESIGN REQUIREMENTS. SIDEWALKS MUST START WITHIN 12" OF THE ROW LINE.
4. SEE LAND DEVELOPMENT PROCEDURES MANUAL, VOLUME 2, SECTION 2.3 FOR PAVEMENT DESIGN REQUIREMENTS.

**CITY OF JACKSONVILLE
STANDARD**

**DESIGN CLASSIFICATION Q
RESIDENTIAL LOCAL
SUBDIVISION**

N.T.S.

PLATE P-127

DATE DRAWN 10-6-17

REVISED DATE 11-22-24

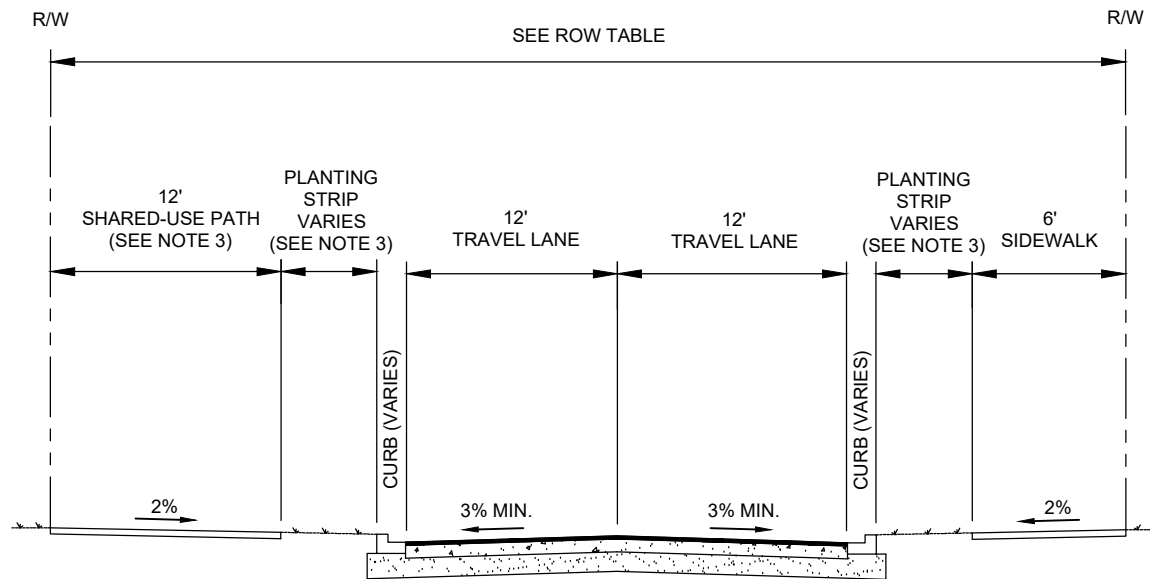

NOTES:

1. ALL DISTURBED AREAS SHALL BE SEEDED & MULCHED. ALL AREAS WHERE SOD HAS BEEN DISTURBED OR REMOVED SHALL BE RESODDED.
2. SEE LAND DEVELOPMENT PROCEDURES MANUAL, VOLUME 2, SECTION 2.4 FOR BICYCLE FACILITY DESIGN REQUIREMENTS AND BIKE FACILITY PREFERENCES.
3. PLANTING STRIP TO HAVE A MINIMUM 5' WIDTH. 8' IS DESIRED IF STREET TREES ARE INCLUDED.
4. SEE LAND DEVELOPMENT PROCEDURES MANUAL, VOLUME 2, TABLE 2.2-1 FOR SIDEWALK DESIGN REQUIREMENTS. SIDEWALKS MUST START WITHIN 12" OF THE ROW LINE.
5. SEE LAND DEVELOPMENT PROCEDURES MANUAL, VOLUME 2, SECTION 2.3 FOR PAVEMENT DESIGN REQUIREMENTS.

FUNCTIONAL HIGHWAY CLASSIFICATION	ROADWAY DESIGN MATRIX	DEVELOPMENT AREA	TYPICAL NUMBER OF TRAVEL LANES	MINIMUM ROW (FT)
MINOR ARTERIAL	F	ALL	4	120
COLLECTOR	I	DOWNTOWN, URBAN, URBAN PRIORITY, SUBURBAN	3	80
		RURAL		100
LOCAL	M	DOWNTOWN, URBAN, URBAN PRIORITY, SUBURBAN	2	60
		RURAL		80

**CITY OF JACKSONVILLE
STANDARD**

**DESIGN CLASSIFICATION F/I/M
INDUSTRIAL**

N.T.S.

PLATE P-128

DATE DRAWN 9-9-20

REVISED DATE 11-22-24

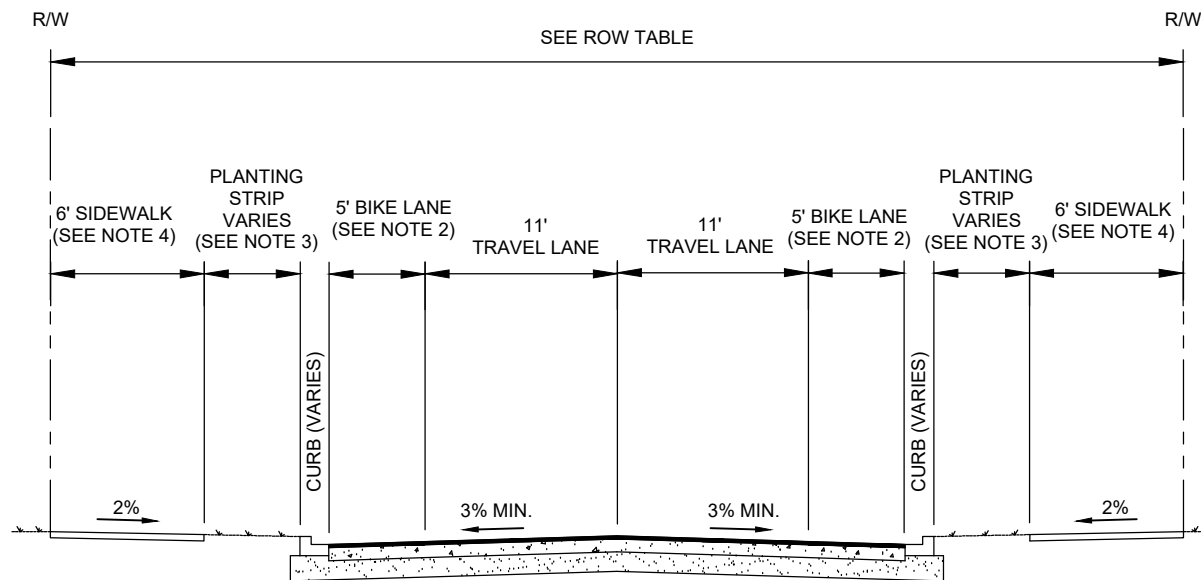

NOTES:

1. ALL DISTURBED AREAS SHALL BE SEEDED & MULCHED. ALL AREAS WHERE SOD HAS BEEN DISTURBED OR REMOVED SHALL BE RESODDED.
2. SEE LAND DEVELOPMENT PROCEDURES MANUAL, VOLUME 2, SECTION 2.4 FOR BICYCLE FACILITY DESIGN REQUIREMENTS AND BIKE FACILITY PREFERENCES.
3. PLANTING STRIP TO HAVE A MINIMUM 5' WIDTH. 8' IS DESIRED IF STREET TREES ARE INCLUDED.
4. SEE LAND DEVELOPMENT PROCEDURES MANUAL, VOLUME 2, TABLE 2.2-1 FOR SIDEWALK DESIGN REQUIREMENTS. SIDEWALKS MUST START WITHIN 12" OF THE ROW LINE.
5. SEE LAND DEVELOPMENT PROCEDURES MANUAL, VOLUME 2, SECTION 2.3 FOR PAVEMENT DESIGN REQUIREMENTS.

FUNCTIONAL HIGHWAY CLASSIFICATION	ROADWAY DESIGN MATRIX	DEVELOPMENT AREA	TYPICAL NUMBER OF TRAVEL LANES	MINIMUM ROW (FT)
COLLECTOR	K	DOWNTOWN, URBAN, URBAN PRIORITY, SUBURBAN	3	80
		RURAL		100
LOCAL	O	DOWNTOWN, URBAN, URBAN PRIORITY, SUBURBAN	2	60
		RURAL		80

**CITY OF JACKSONVILLE
STANDARD**

**DESIGN CLASSIFICATION K/O
BUSINESS PARK**

N.T.S.

PLATE P-129

DATE DRAWN 9-9-20

REVISED DATE 11-22-24

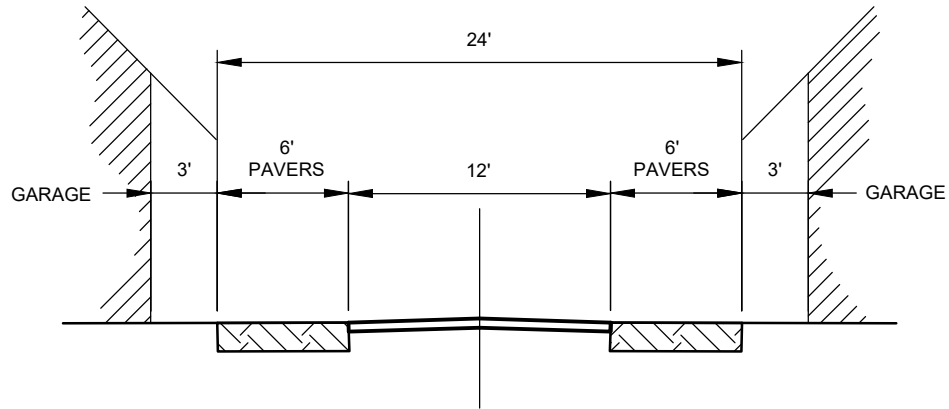

NOTE:

1. SEE LAND DEVELOPMENT PROCEDURES MANUAL, VOLUME 2, TABLE 2.2-1 FOR ROADWAY DESIGN REQUIREMENTS.

CITY OF JACKSONVILLE
STANDARD

STREET CLASSIFICATION R
ALLEY

N.T.S.

PLATE P-130

DATE DRAWN 9-9-20

REVISED DATE 11-22-24

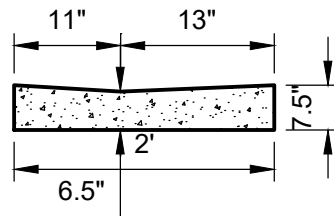
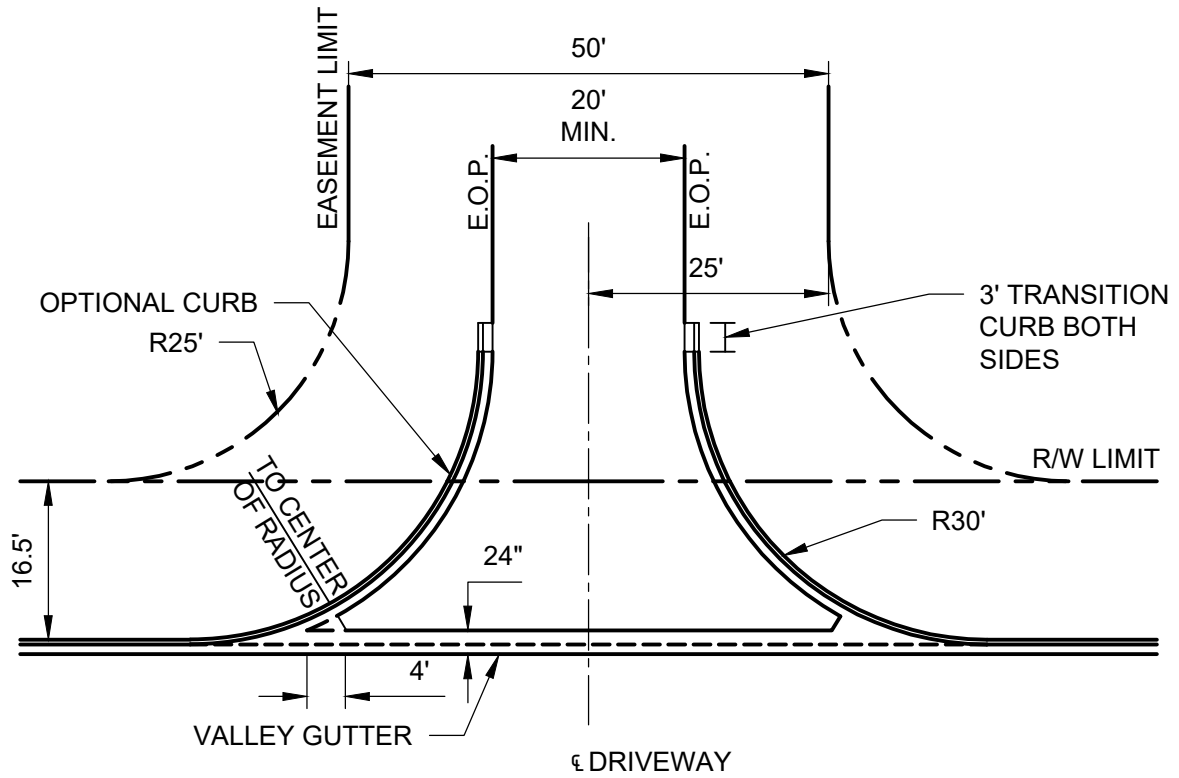

TYPICAL CONC. VALLEY
(MIN. 3500 PSI CONC.)

NOTE:

THAT PORTION OF DRIVEWAY THAT EXTENDS INTO PUBLIC R/W SHALL HAVE 1 1/4" ASPHALTIC CONCRETE ON 6" LIMEROCK BASE/ 12" STABILIZED SUBGRADE OR 12" LIMEROCK BASE ON COMPACTED SUBGRADE.

PRIVATE ROAD DRIVEWAY
ENTRANCES

CITY OF
JACKSONVILLE
STANDARD

N.T.S.

PLATE P-201

DATE DRAWN 11-5-81

REVISED DATE 10-15-97

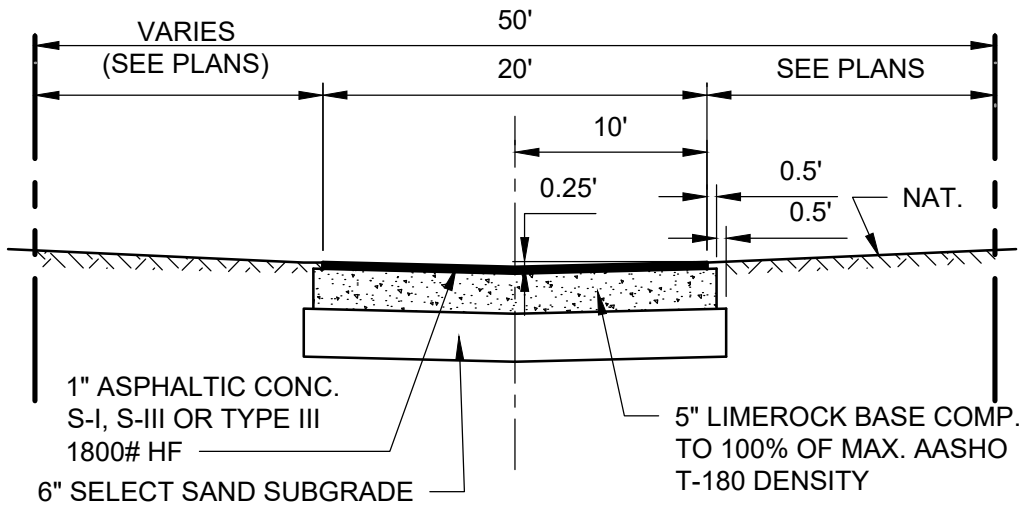
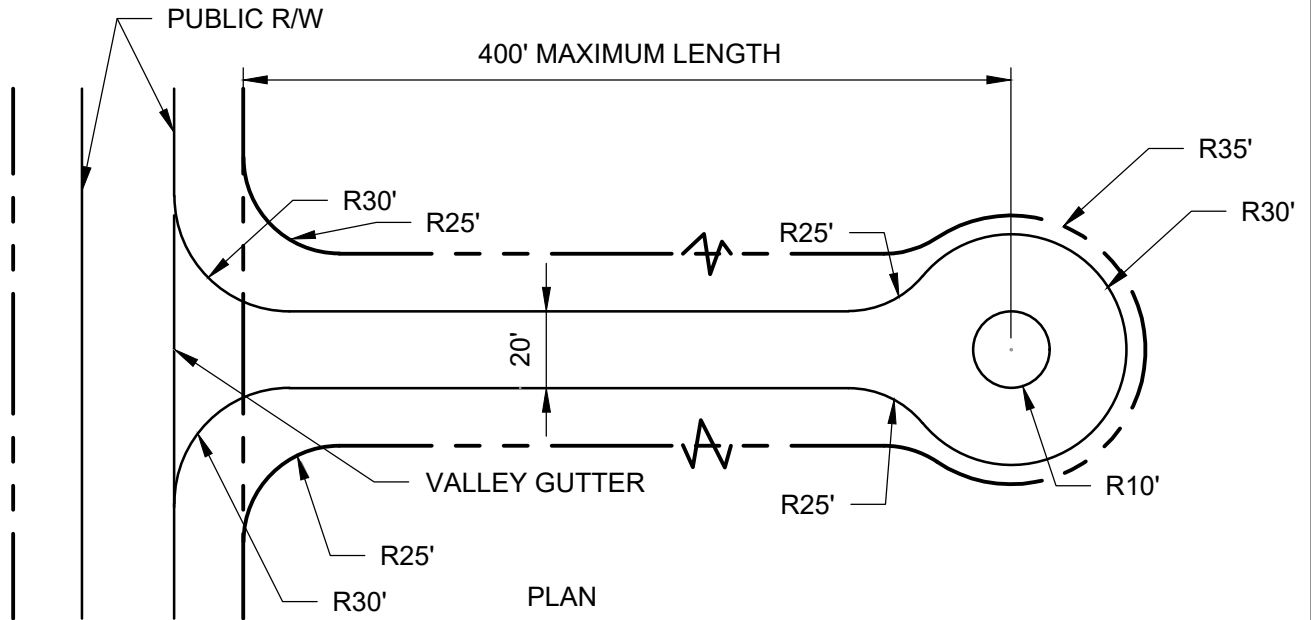

PRIVATE DRIVES ONLY TYPICAL CROSS SECTION

NOTES:

1. THAT PORTION OF DRIVEWAY THAT EXTENDS INTO PUBLIC R/W SHALL HAVE 1 1/4" ASPHALTIC CONCRETE ON 6" LIMEROCK BASE/ 12" STABILIZED SUBGRADE OR 12" LIMEROCK BASE ON COMPACTED SUBGRADE.
2. NOTE: SUCH DRIVES ARE SPECIFICALLY PROHIBITED FROM BEING DEDICATED TO THE CITY OF JACKSONVILLE FOR MAINTENANCE.
3. THE USE OF INVERTED CROWN SECTION (PRIVATE DRIVE) IS FOR USE ONLY WITHIN PLANNED UNIT DEVELOPMENTS WHERE SUCH REZONING SPECIFICALLY PROVIDES FOR ITS USE. IT IS INTENDED THAT SUCH DRIVES BE UTILIZED ONLY WITHIN PATIO HOME/ZERO LOT LINE DEVELOPMENTS AND OWNED BY AN UNDIVIDED, PROPORTIONATE SHARE INTEREST OF CONTIGUOUS PROPERTY OWNERS.

INVERTED CROWN PRIVATE DRIVE	CITY OF JACKSONVILLE STANDARD	N.T.S.	PLATE P-202
		DATE DRAWN	5-10-89
		REVISED DATE	12-06-24

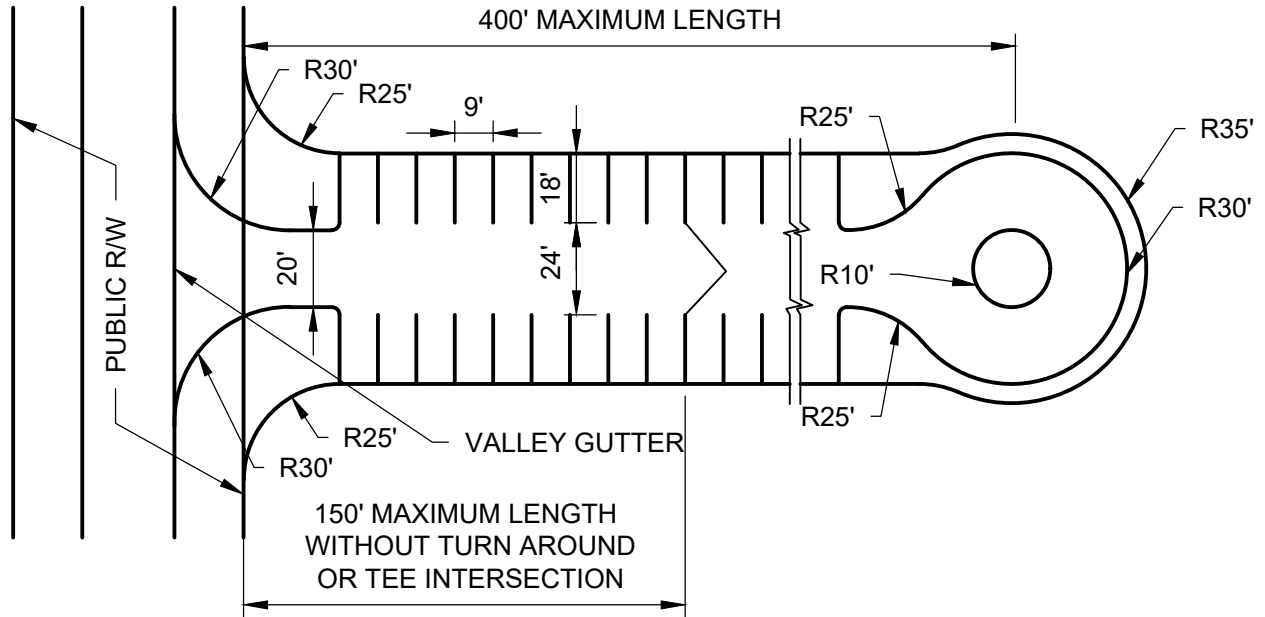

PLAN

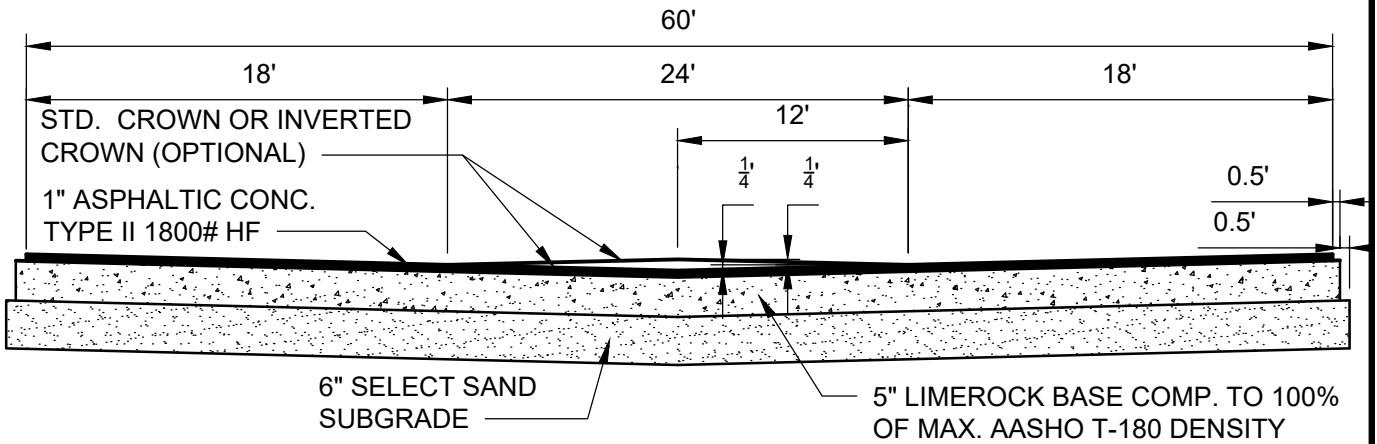

PRIVATE DRIVES ONLY TYPICAL
CROSS SECTION

NOTES:

1. THAT PORTION OF DRIVEWAY THAT EXTENDS INTO PUBLIC R/W SHALL HAVE 1 1/4" ASPHALTIC CONCRETE ON 6" LIMEROCK BASE/ 12" STABILIZED SUBGRADE OR 12" LIMEROCK BASE ON COMPACTED SUBGRADE.
2. SUCH DRIVES ARE SPECIFICALLY PROHIBITED FROM BEING DEDICATED TO THE CITY OF JACKSONVILLE FOR MAINTENANCE.
3. THIS SECTION (PRIVATE DRIVE) IS FOR USE ONLY WITHIN PLANNED UNIT DEVELOPMENTS WHERE SUCH REZONING SPECIFICALLY PROVIDES FOR ITS USE. PAVEMENTS ARE TO BE OWNED BY AN UNDIVIDED, PROPORTIONATE SHARE INTEREST OF CONTIGUOUS PROPERTY OWNERS.

PRIVATE DRIVE WITH PARKING	CITY OF JACKSONVILLE STANDARD	N.T.S.	PLATE P-203
		DATE DRAWN	05-24-89
		REVISED DATE	12-06-24

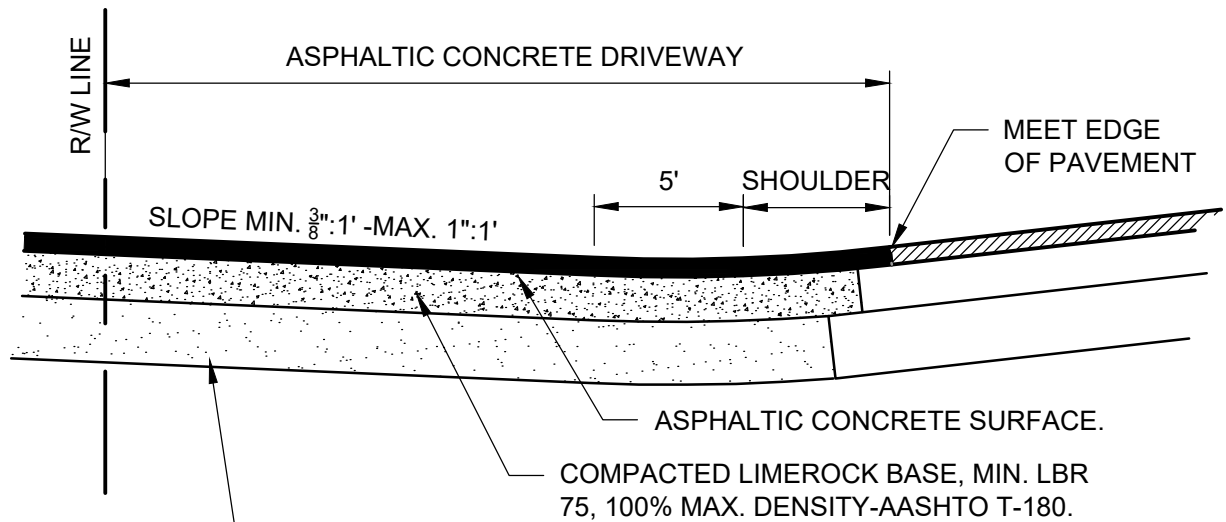
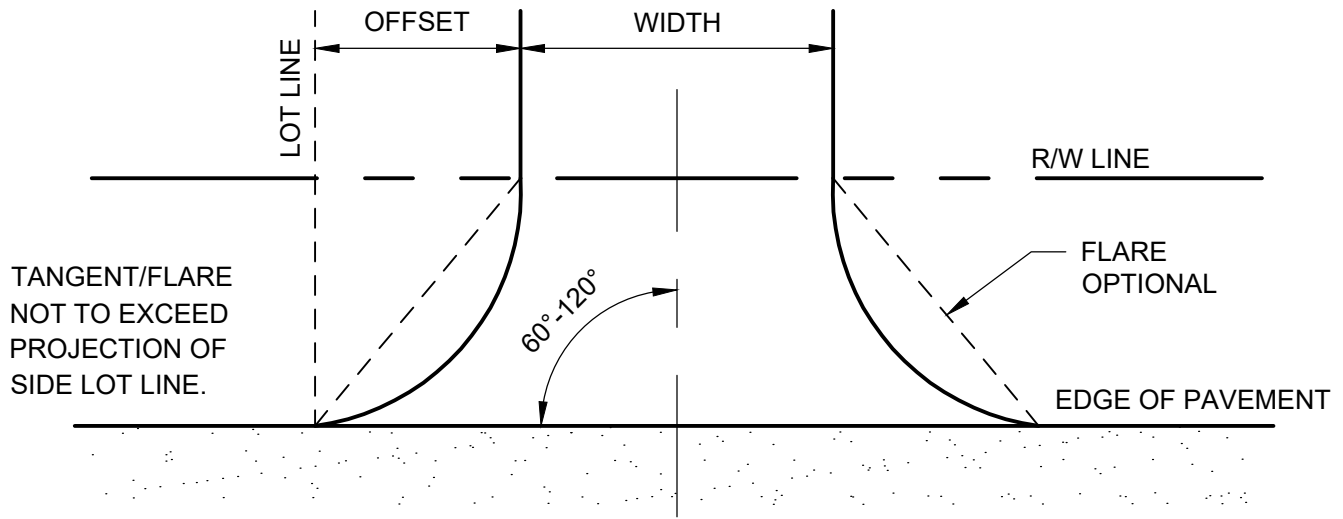

SUB-BASE OPTIONS (SEE CHART BELOW FOR THICKNESSES).

1. STABILIZED SUB-BASE MIN. LBR 30 COMPACTED TO 95% OF MAX. DENSITY AASHTO T-180.
2. SUB-BASE COMPACTED TO 95% OF MAX. DENSITY AASHTO T-180.

NOTES:

1. ALL DRIVEWAYS CONSTRUCTED WITHIN CITY MAINTAINED RIGHT-OF-WAYS SHALL CONFORM TO CITY STANDARDS. A PERMIT MUST BE ISSUED BY THE DEPARTMENT OF PUBLIC WORKS FOR ALL SUCH WORK.
2. ALL MATERIALS SHALL CONFORM TO CITY STANDARDS.
3. ALL DRIVEWAYS CONSTRUCTED WITHIN STATE MAINTAINED RIGHT-OF-WAYS SHALL CONFORM TO D.O.T. STANDARDS.

DRIVEWAY TYPE	MIN. WIDTH	MAX. WIDTH	PAVEMENT OPTION #1			PAVEMENT OPTION #2			MIN. RADIUS	MIN. OFFSET	OPTIONAL FLARE
			ASPHALT	LIME ROCK	STABILIZED SUB-BASE	ASPHALT	LIME ROCK	STABILIZED SUB-BASE			
CLASS I RESIDENTIAL	8'	24'	1 1/4"	6"	6"	1 1/4"	8"	4"	3'	3'	3'
CLASS II COMMERCIAL	24'	36'	1 1/4"	6"	12"	1 1/4"	8"	6"	30'	30'	7'
CLASS III HIGH VOLUME	24'	36'	1 1/4"	8"	12"	1 1/4"	12"	12"	30'	30'	N/A

STANDARD ASPHALTIC
CONCRETE DRIVEWAY

CITY OF
JACKSONVILLE
STANDARD

N.T.S.

PLATE P-204

DATE DRAWN 11-19-81

REVISED DATE 12-06-24

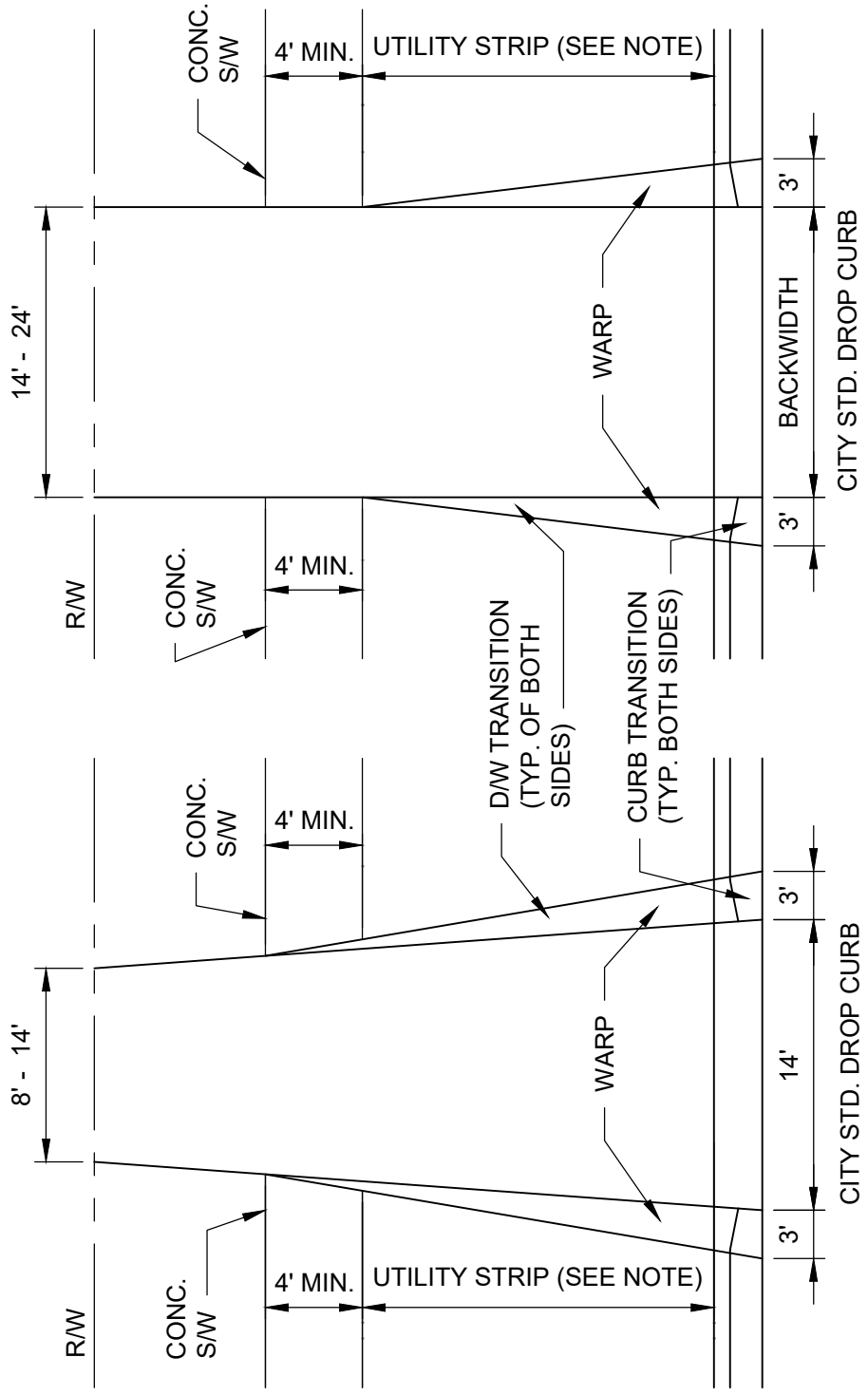

NOTE:

WHERE UTILITY STRIP IS LESS THAN 5', D/W TRANS. TO MEET BACK OF S/W. WHERE UTILITY STRIP IS 5' OR GREATER, D/W TRANS. TO MEET FRONT OF S/W.

STANDARD & OPTIONAL
FLARED CONCRETE
DRIVEWAY DETAIL

CITY OF
JACKSONVILLE
STANDARD

N.T.S.

PLATE P-205

DATE DRAWN 10-10-97

REVISED DATE 12-06-24

STANDARD DRIVEWAY CONSTRUCTION ENGINEERING DIVISION -

CITY OF JACKSONVILLE, FLORIDA

PERMIT REQUIRED

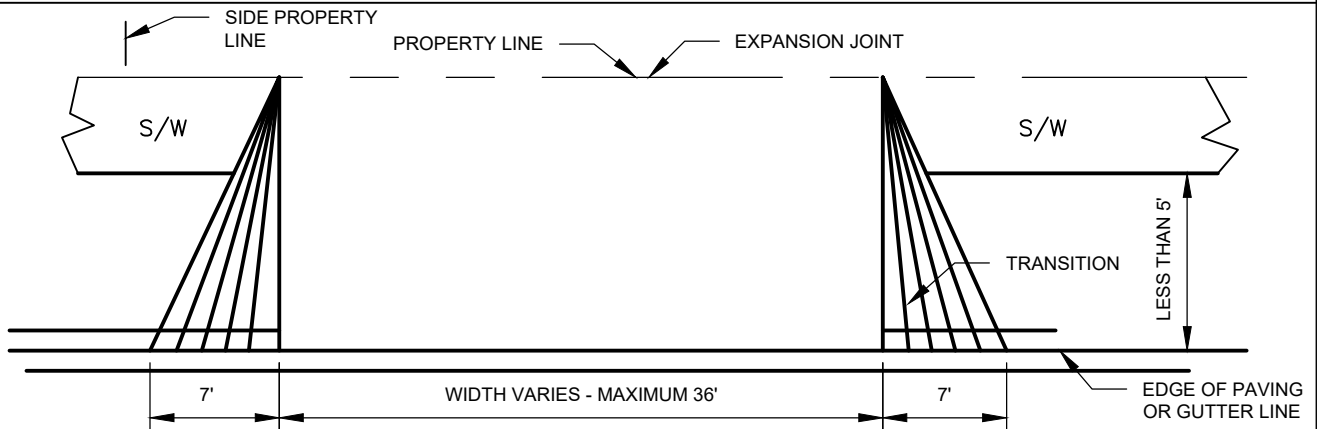
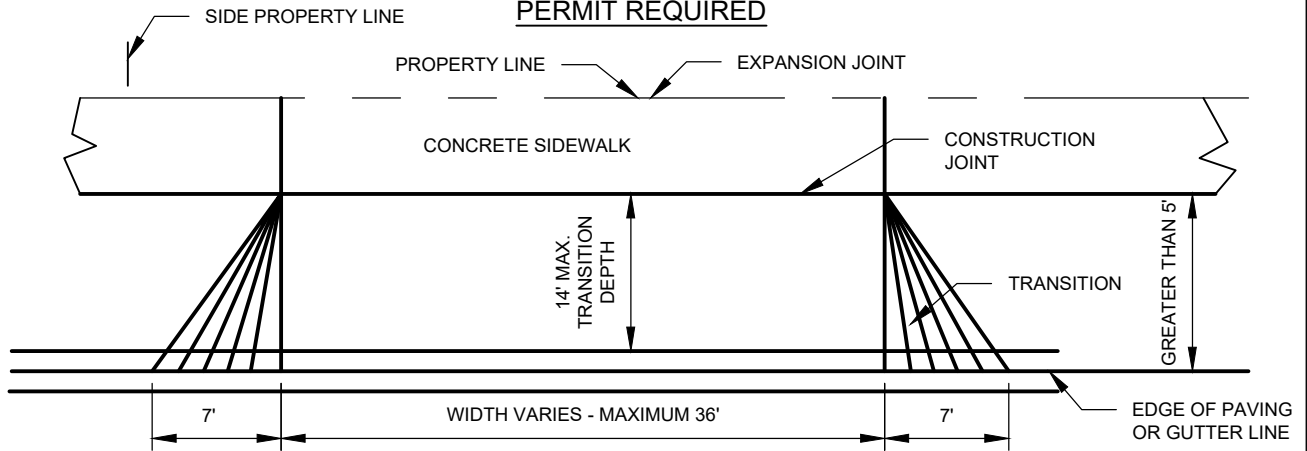

**GRADING DETAIL FOR DRIVEWAYS
WHEN HIGH CURB EXISTS**

TYPE-1

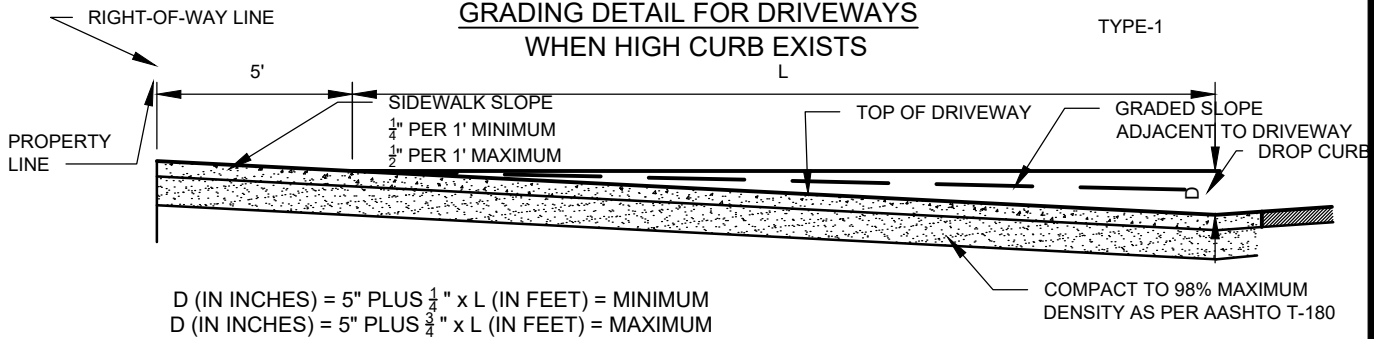

D (IN INCHES) = 5" PLUS $\frac{1}{4}$ " x L (IN FEET) = MINIMUM
 D (IN INCHES) = 5" PLUS $\frac{3}{4}$ " x L (IN FEET) = MAXIMUM

COMPACT TO 98% MAXIMUM DENSITY AS PER AASHTO T-180

WHEN ROLL OR NO CURB EXISTS.

TYPE-2

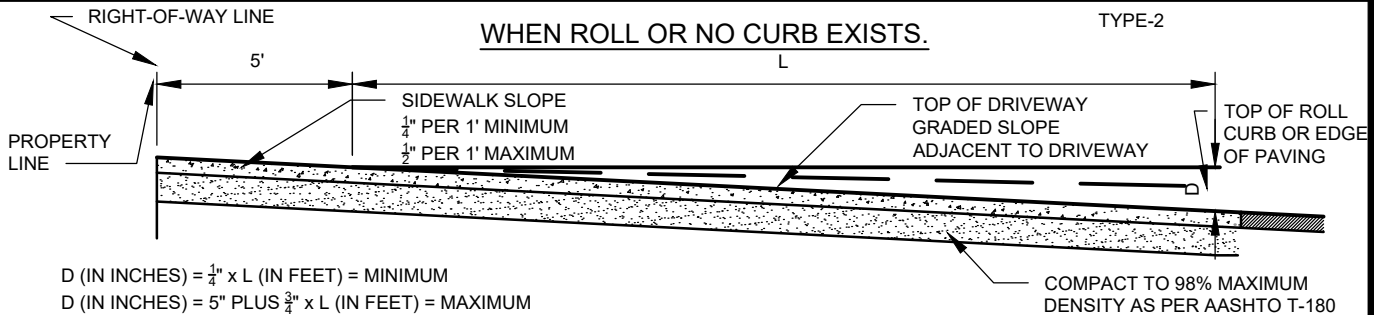

D (IN INCHES) = $\frac{1}{4}$ " x L (IN FEET) = MINIMUM
 D (IN INCHES) = 5" PLUS $\frac{3}{4}$ " x L (IN FEET) = MAXIMUM

COMPACT TO 98% MAXIMUM DENSITY AS PER AASHTO T-180

NOTE:

MOST DRIVEWAY GRADES CAN BE MADE TO FIT THE ABOVE STANDARDS. DRIVEWAYS AND CROSS-OVERS TO BE A MINIMUM OF 2500 P.S.I. CONCRETE. DRIVEWAY NOT TO EXCEED LIMIT OF SIDE PROPERTY LINE. UNDERGROUND UTILITIES MAY EXIST ON SITE. CONTACTOR SHALL CONTACT PROPER AUTHORITIES PRIOR TO CONSTRUCTION.

OPTIONAL FLARED
COMMERCIAL CONCRETE
DRIVEWAY DETAILS

CITY OF
JACKSONVILLE
STANDARD

N.T.S.

PLATE P-206

DATE DRAWN

JULY 1978

REVISED DATE

12-06-24

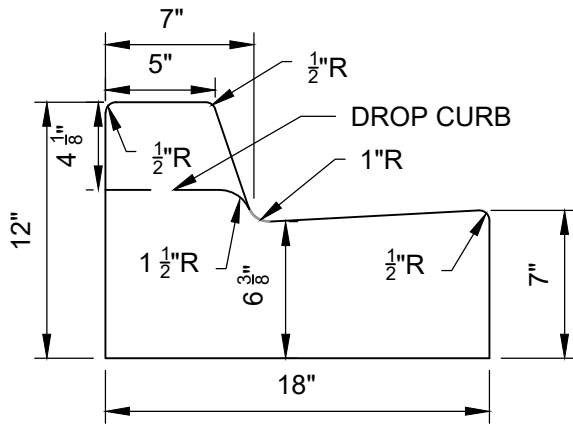

CITY STANDARD

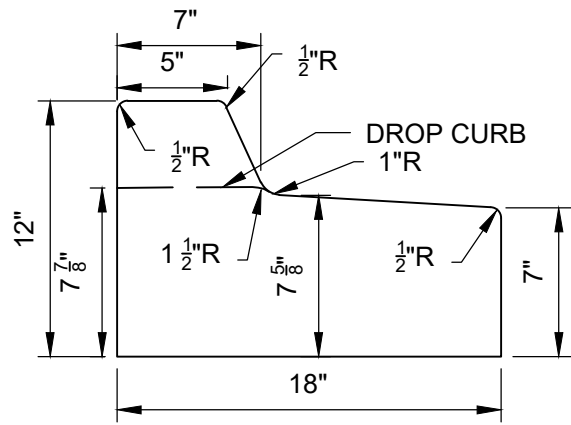

MEDIAN CURB

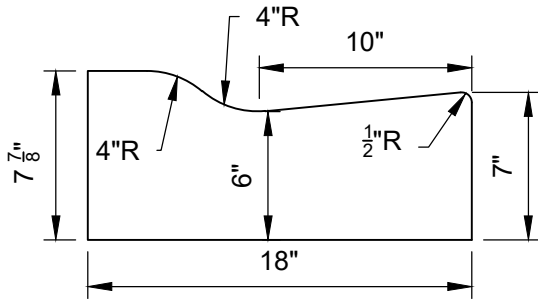

DROP CURB

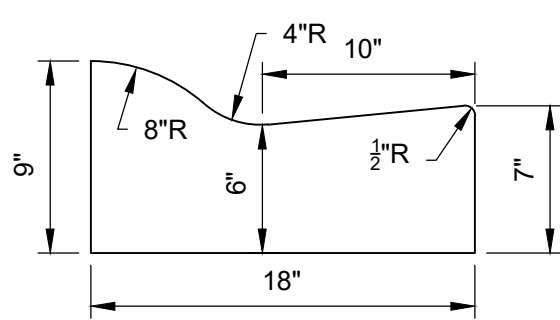

MIAMI CURB

MONOLITHIC
CURB & SIDEWALK

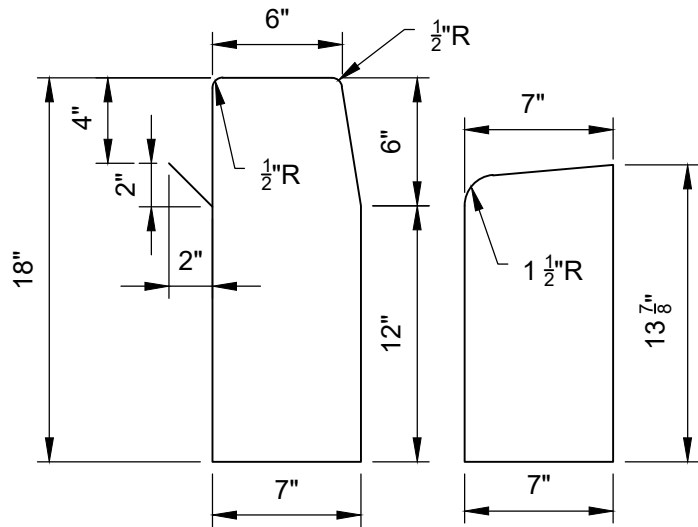

CONCRETE QUANTITIES

HEADER, DROP, &
MONOLITHIC CURB

CITY STANDARD CURB	.0388889	CU. YD./LIN. FT.
STANDARD DROP CURB	.0322222	CU. YD./LIN. FT.
MEDIAN CURB	.0411111	CU. YD./LIN. FT.
MIAMI CURB	.0325926	CU. YD./LIN. FT.
HEADER CURB	.0314815	CU. YD./LIN. FT.
HEADER DROP CURB	.0244444	CU. YD./LIN. FT.

CITY STANDARD
CURB TEMPLATES

CITY OF
JACKSONVILLE
STANDARD

N.T.S.

PLATE P-301

DATE DRAWN 11-07-72

REVISED DATE 12-06-24

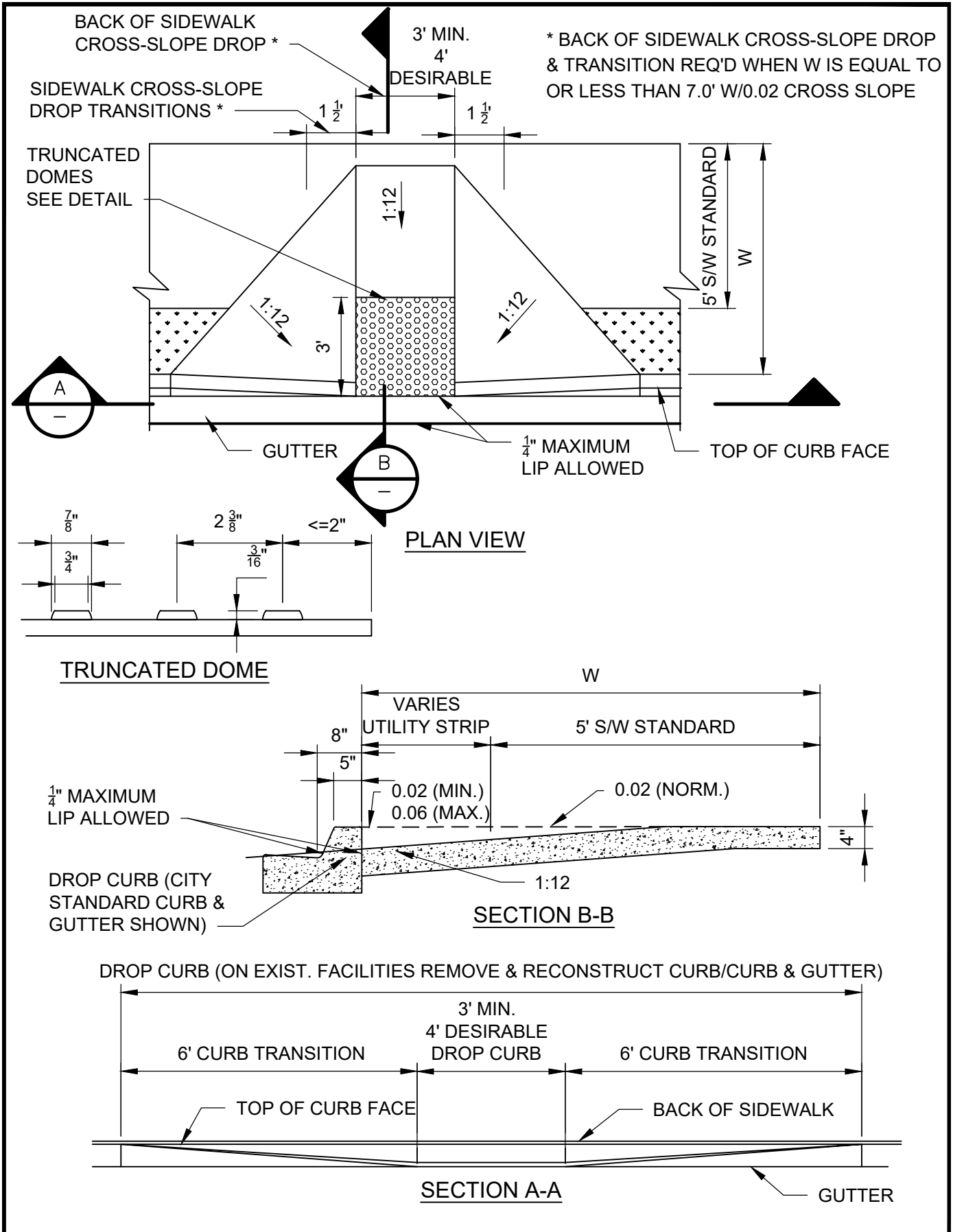

* BACK OF SIDEWALK CROSS-SLOPE DROP & TRANSITION REQ'D WHEN W IS EQUAL TO OR LESS THAN 7.0' W/0.02 CROSS SLOPE

CURB CUT RAMP FACILITY FOR PHYSICALLY HANDICAPPED CITY STANDARD CURB & GUTTER

CITY OF JACKSONVILLE STANDARD

N.T.S.	PLATE P-302
DATE DRAWN	08-12-93
REVISED DATE	12-06-24

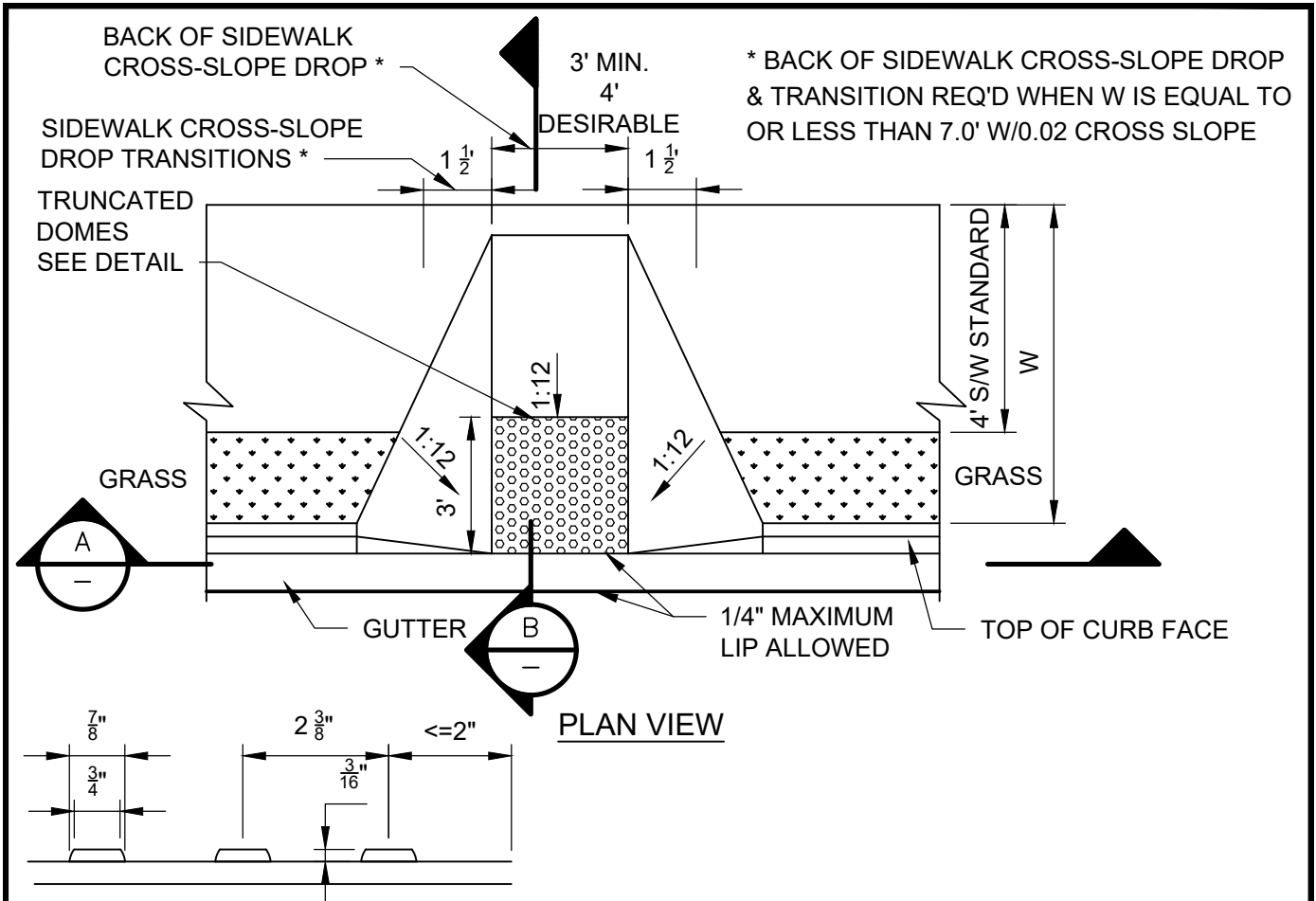

* BACK OF SIDEWALK CROSS-SLOPE DROP & TRANSITION REQ'D WHEN W IS EQUAL TO OR LESS THAN 7.0' W/0.02 CROSS SLOPE

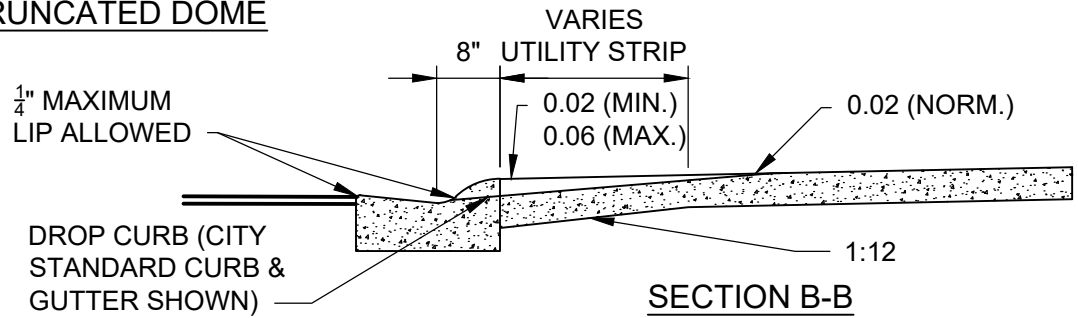
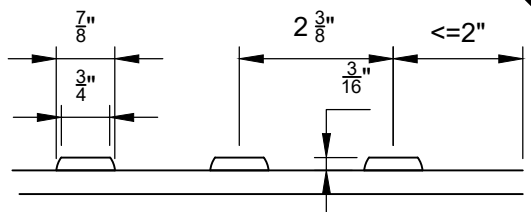

DROP CURB (ON EXIST. FACILITIES REMOVE & RECONSTRUCT CURB/CURB & GUTTER)

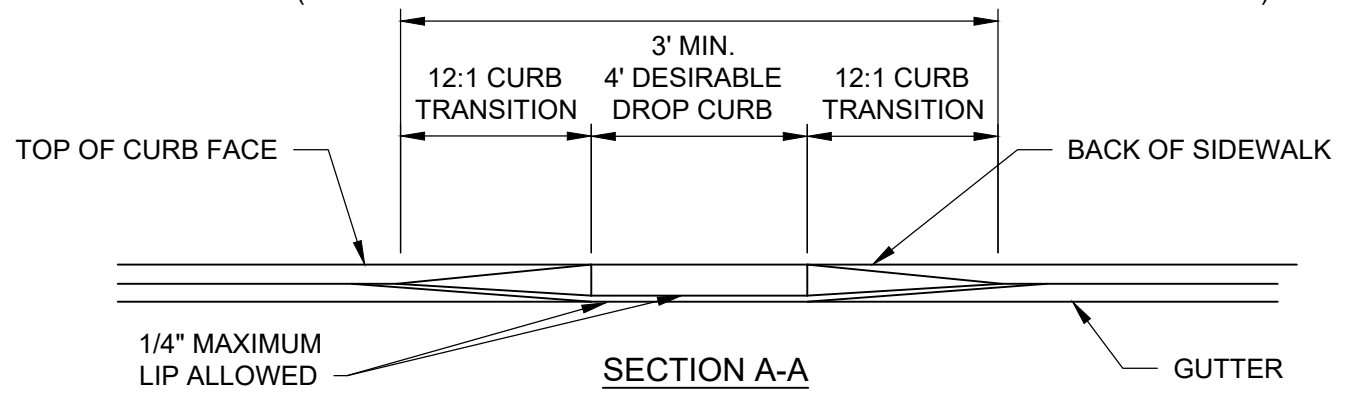

CURB CUT RAMP FACILITY FOR PHYSICALLY HANDICAPPED MIAMI CURB & GUTTER	CITY OF JACKSONVILLE STANDARD	N.T.S.	PLATE P-303
		DATE DRAWN	08-12-93
		REVISED DATE	12-06-24

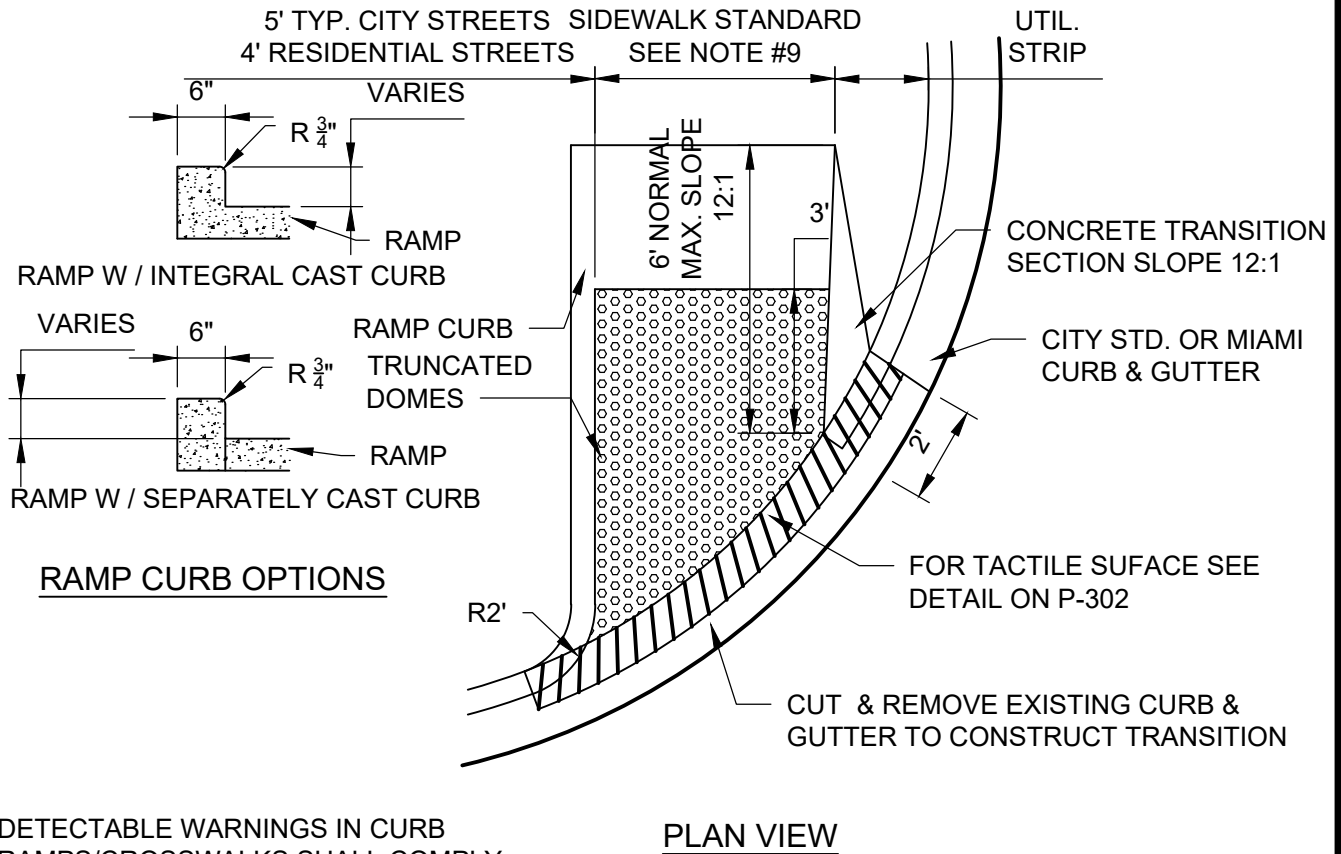
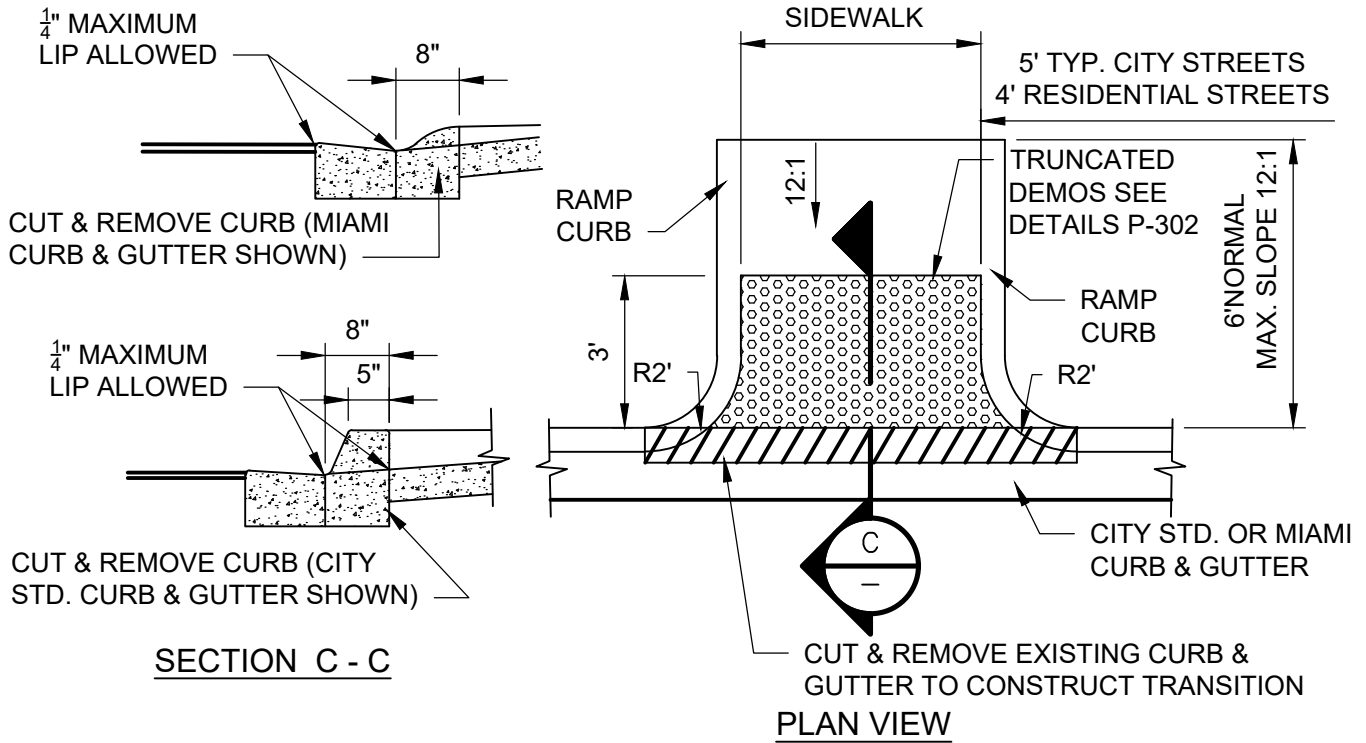

DETECTABLE WARNINGS IN CURB RAMPS/CROSSWALKS SHALL COMPLY WITH ALL ADA REQUIREMENTS INCLUDING 4.7.7 / 4.29 AND FDOT INDEX NO. 304

CURB CUT RAMP FACILITY FOR PHYSICALLY HANDICAPPED

CITY OF JACKSONVILLE STANDARD

N.T.S.

PLATE P-304

DATE DRAWN 08-12-93

REVISED DATE 12-06-24

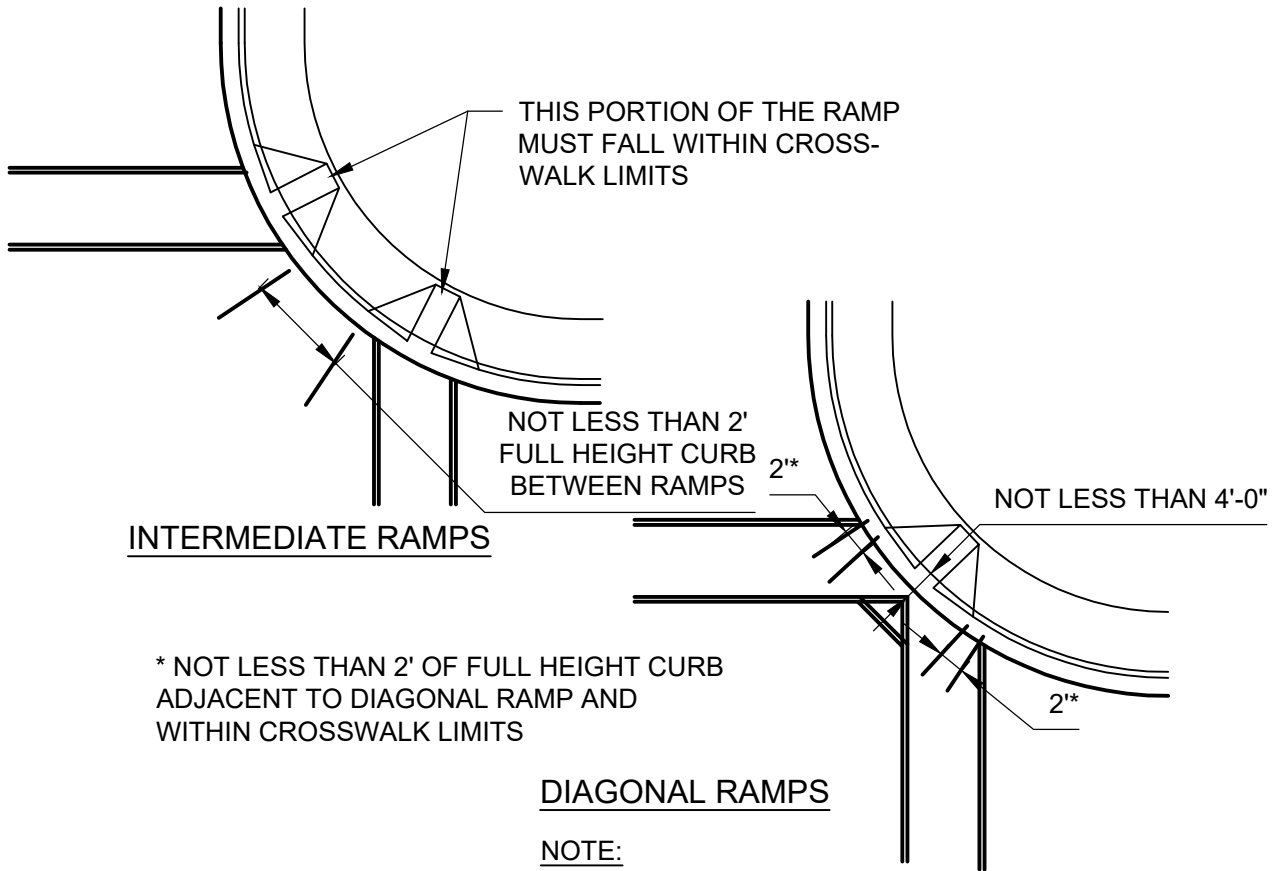

* NOT LESS THAN 2' OF FULL HEIGHT CURB ADJACENT TO DIAGONAL RAMP AND WITHIN CROSSWALK LIMITS

DIAGONAL RAMPS

NOTE:

DIAGONAL RAMPS ARE ONLY TO BE USED WITH THE APPROVAL OF THE CITY TRAFFIC ENGINEER.

GENERAL NOTES:

1. CURB CUT RAMPS ARE TO BE CONSTRUCTED ON ALL CURBED FACILITIES, BUT ONLY AT THOSE LOCATIONS WHERE A MARKED CROSSWALK ADJOINS A SIDEWALK; THE CROSSWALK & SIDEWALK EACH CAN BE EITHER EXISTING TO REMAIN OR NEW MARKINGS & CONSTRUCTION.
2. RAMP LOCATIONS ARE TO BE COORDINATED WITH & IN CONFORMANCE WITH CROSSWALK MARKING DETAILS AS SHOWN IN THE PLANS.
3. IF A CURB RAMP IS LOCATED WHERE PEDESTRIANS MUST WALK ACROSS THE RAMP, THEN IT SHALL HAVE FLARED SIDES; THE MAXIMUM SLOPE OF THE FLARE SHALL BE 12:1.
4. RAMPS TO BE CONSTRUCTED AT ALL LOCATIONS SHOWN ON PLANS EVEN WHEN SIDEWALK IS NOT CONSTRUCTED CONCURRENTLY.
5. BASIS OF PAYMENT: CONTRACT UNIT PRICE ESTABLISHED IN THE PROPOSAL FOR CURB & GUTTER.
6. THIS STANDARD IS NOT INTENDED TO BE ABSOLUTE. FINAL DETERMINATIONS TO BE MADE IN THE FIELD.
7. MIAMI CURB WITHIN LIMITS OF WHEEL CHAIR RAMP TO BE "LOW CURB" TO ACCOMODATE 12:1 MAXIMUM RATE FROM GUTTER TO END OF TRANSITION. MAIMI TYPE CURB & GUTTER DETAILS SIMULAR, CURB TRANSITION LENGTH SHALL BE 3'-0".
8. SIDEWALK WIDTH TO MEET REQUIREMENTS OF THE GOVERNING STANDARDS, REGULATIONS AND SPECIFICATIONS, BUT NOT LESS THAN 4'-0"
9. ALL NEW CONCRETE RAMP SURFACES TO RECEIVE TURNATED DOMES.
10. DIAGONAL RAMPS ARE TO BE USED AT RADIUS LESS THAN 50'.

CURB CUT RAMP FACILITY FOR PHYSICALLY HANDICAPPED

CITY OF JACKSONVILLE STANDARD

N.T.S.

PLATE P-305

DATE DRAWN 8-12-93

REVISED DATE 12-06-24

W* = WIDTH OF SIDEWALK VARIES

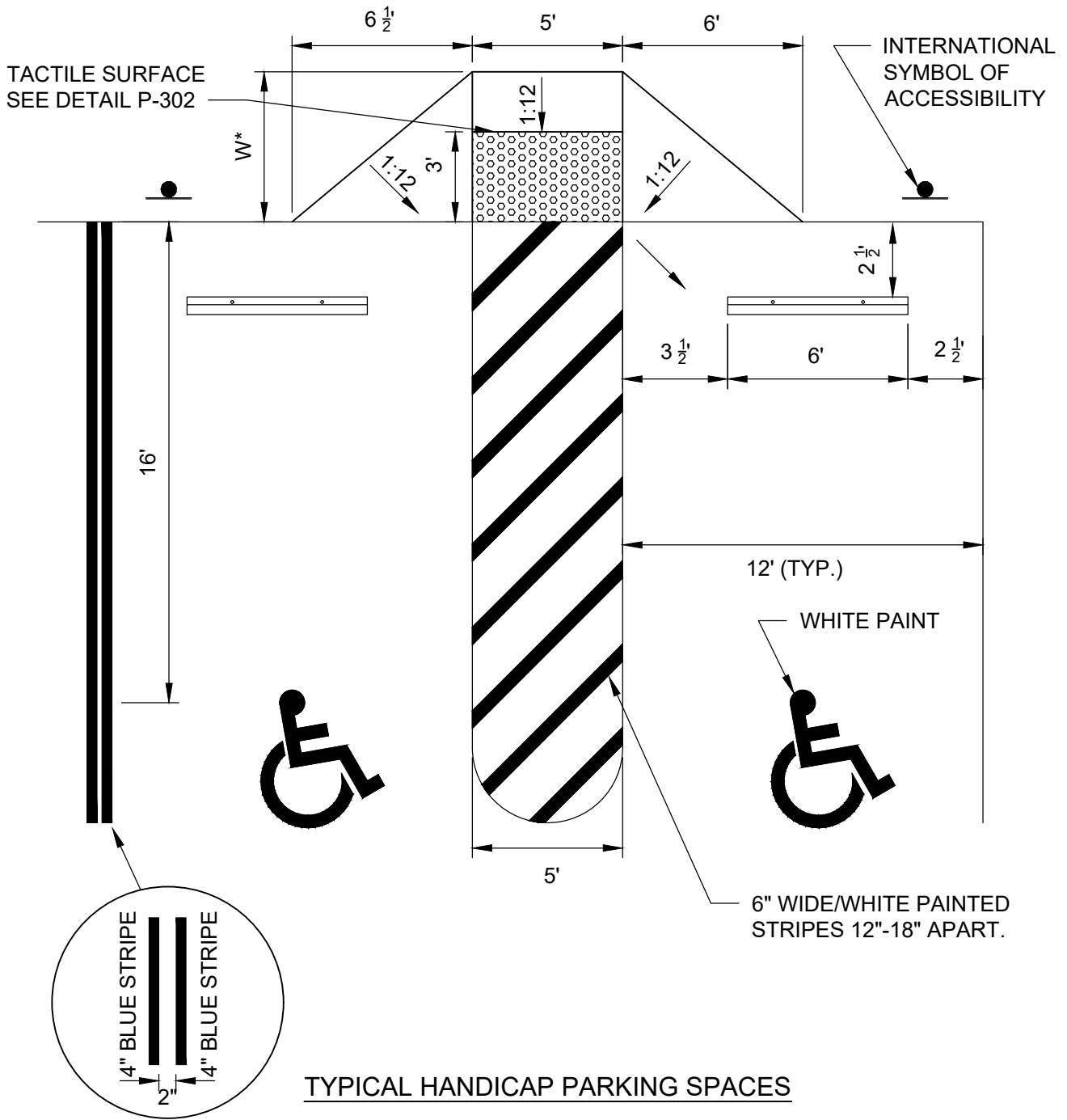

HANDICAP PARKING DETAIL	CITY OF JACKSONVILLE STANDARD	N.T.S.	PLATE P-306
		DATE DRAWN	22-10-97
		REVISED DATE	12-06-24

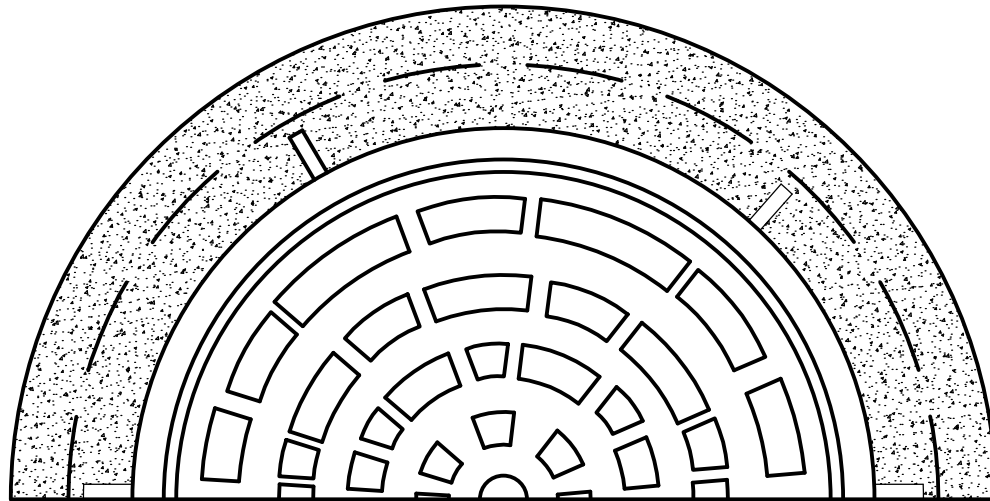

HALF SECTION

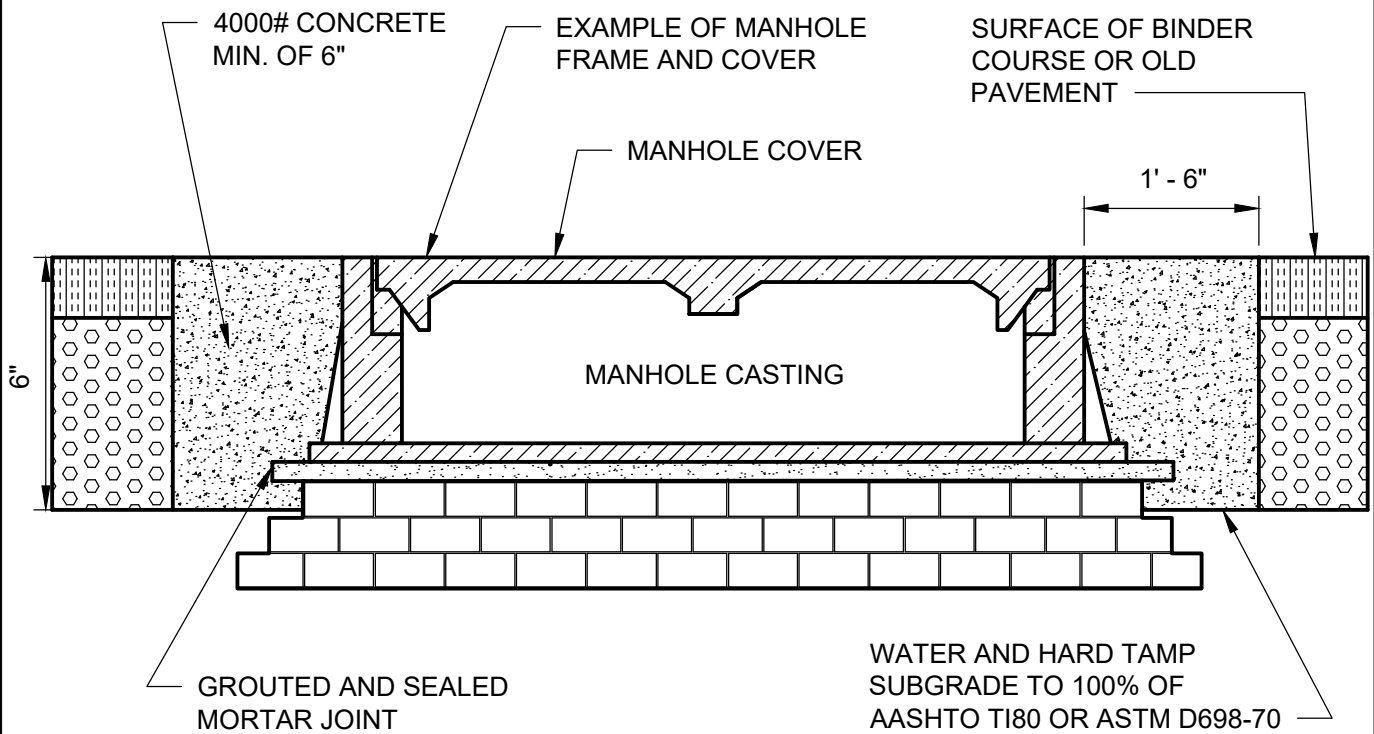

MANHOLE ADJUSTMENT DETAILS

STANDARD PAVING MANHOLE ADJUSTMENT DETAILS	CITY OF JACKSONVILLE STANDARD	N.T.S.	PLATE P-401
		DATE DRAWN	10-30-73
		REVISED DATE	12-06-24

CASE I

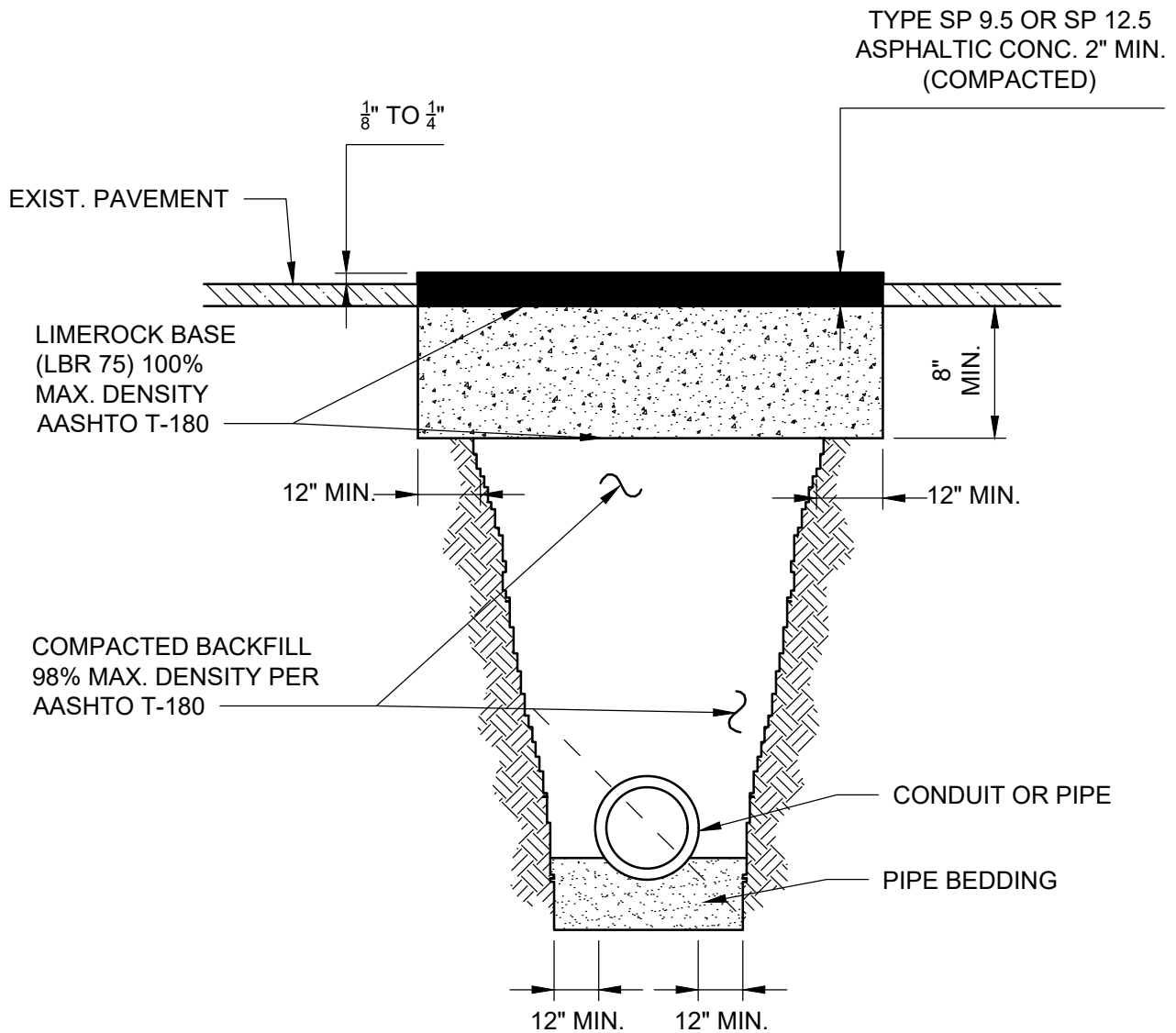

NOTE:

METHOD AND MATERIALS OF REPAIR SUBJECT TO CITY OF JACKSONVILLE CONSTRUCTION REQUIREMENTS FOR NEW FLEXIBLE PAVEMENT.

CASE I STANDARD PAVING REPAIR DETAIL	CITY OF JACKSONVILLE STANDARD		N.T.S.	PLATE P-402
			DATE DRAWN	DEC., 1971
			REVISED DATE	12-06-24

CASE II

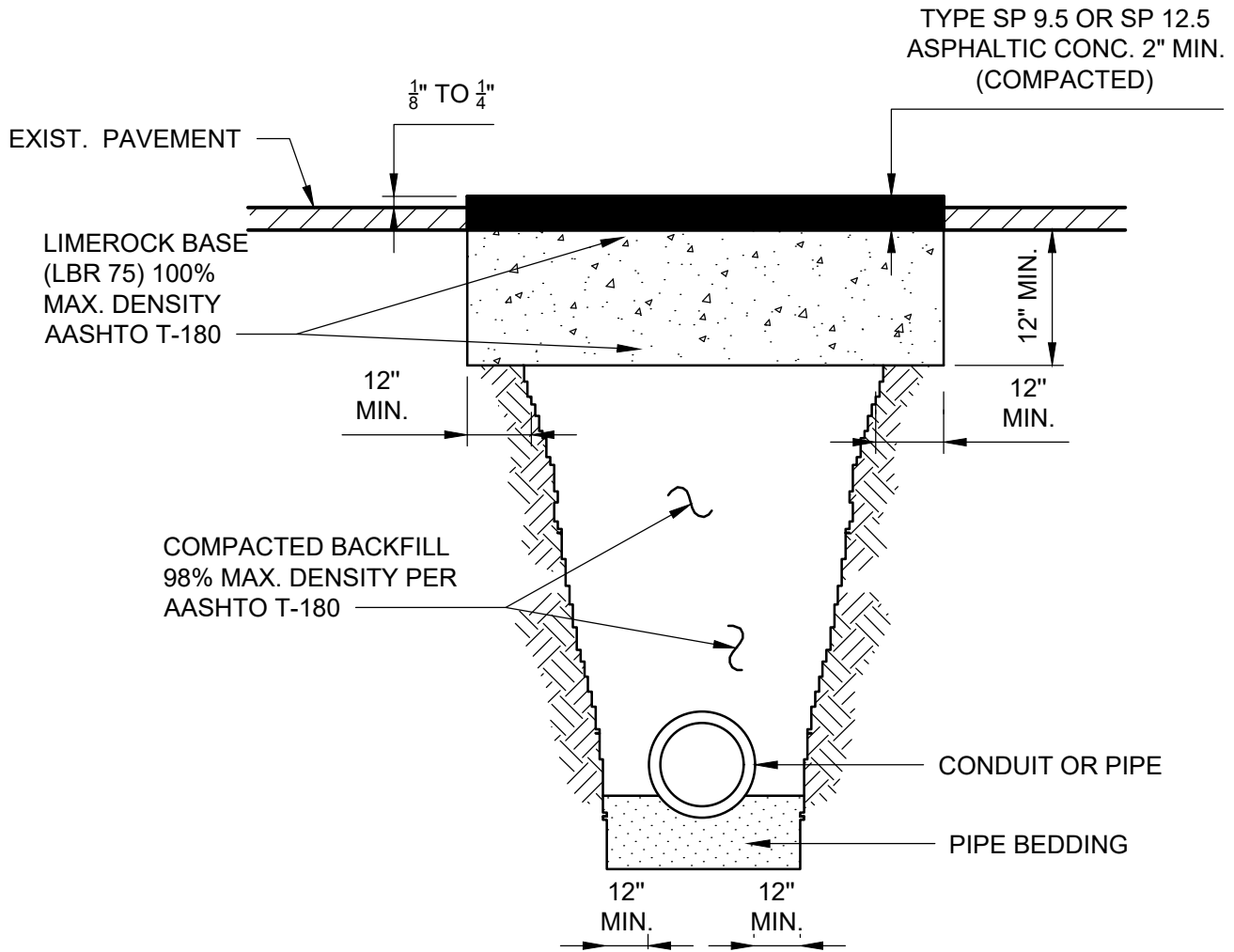

NOTE:

METHOD AND MATERIALS OF REPAIR SUBJECT TO CITY OF JACKSONVILLE CONSTRUCTION REQUIREMENTS FOR NEW FLEXIBLE PAVEMENT.

CASE II STANDARD PAVING REPAIR DETAIL	CITY OF JACKSONVILLE STANDARD	N.T.S.	PLATE P-403
		DATE DRAWN	DEC., 1971
		REVISED DATE	12-06-24

CASE III

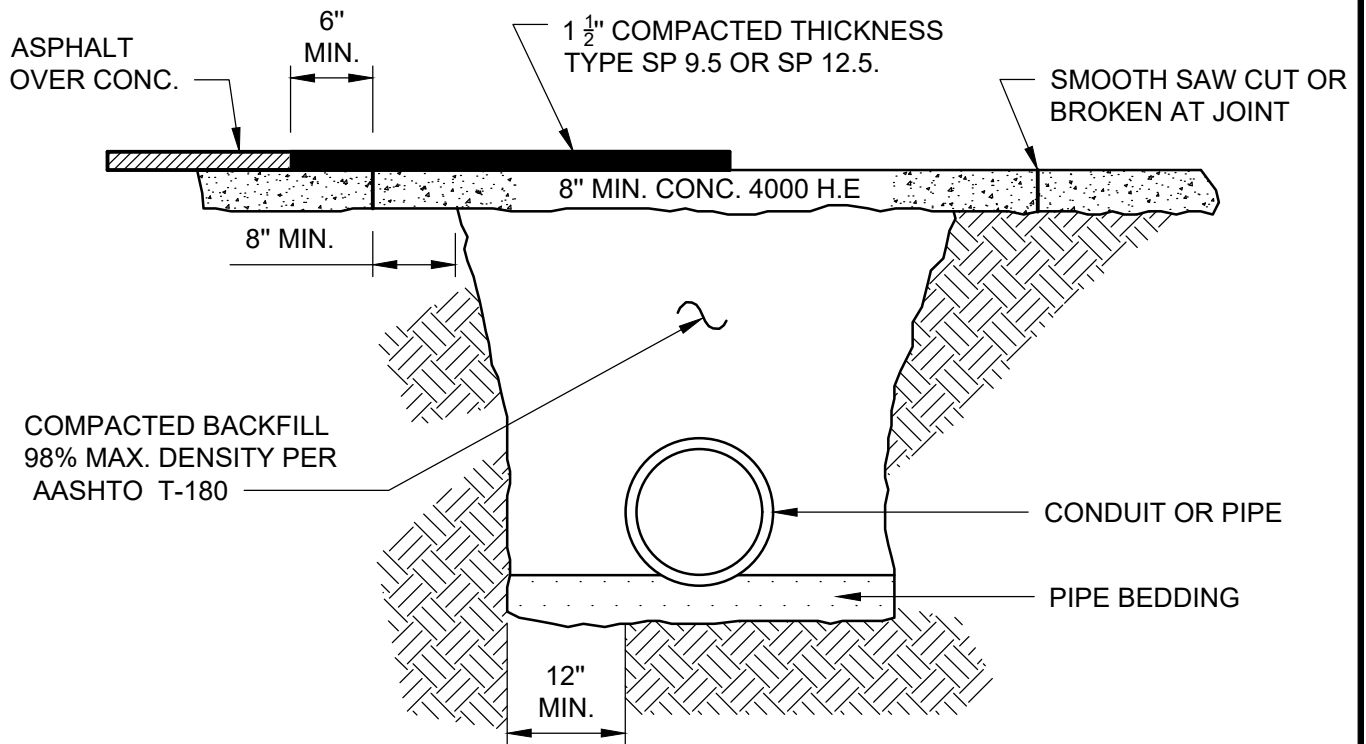

NOTE:

METHOD AND MATERIALS OF REPAIR SUBJECT TO CITY OF JACKSONVILLE CONSTRUCTION REQUIREMENTS FOR NEW FLEXIBLE PAVEMENT.

CASE III
STANDARD PAVING
REPAIR DETAIL

CITY OF
JACKSONVILLE
STANDARD

N.T.S.

PLATE P-404

DATE DRAWN 4/80

REVISED DATE 12-06-24

CASE IV

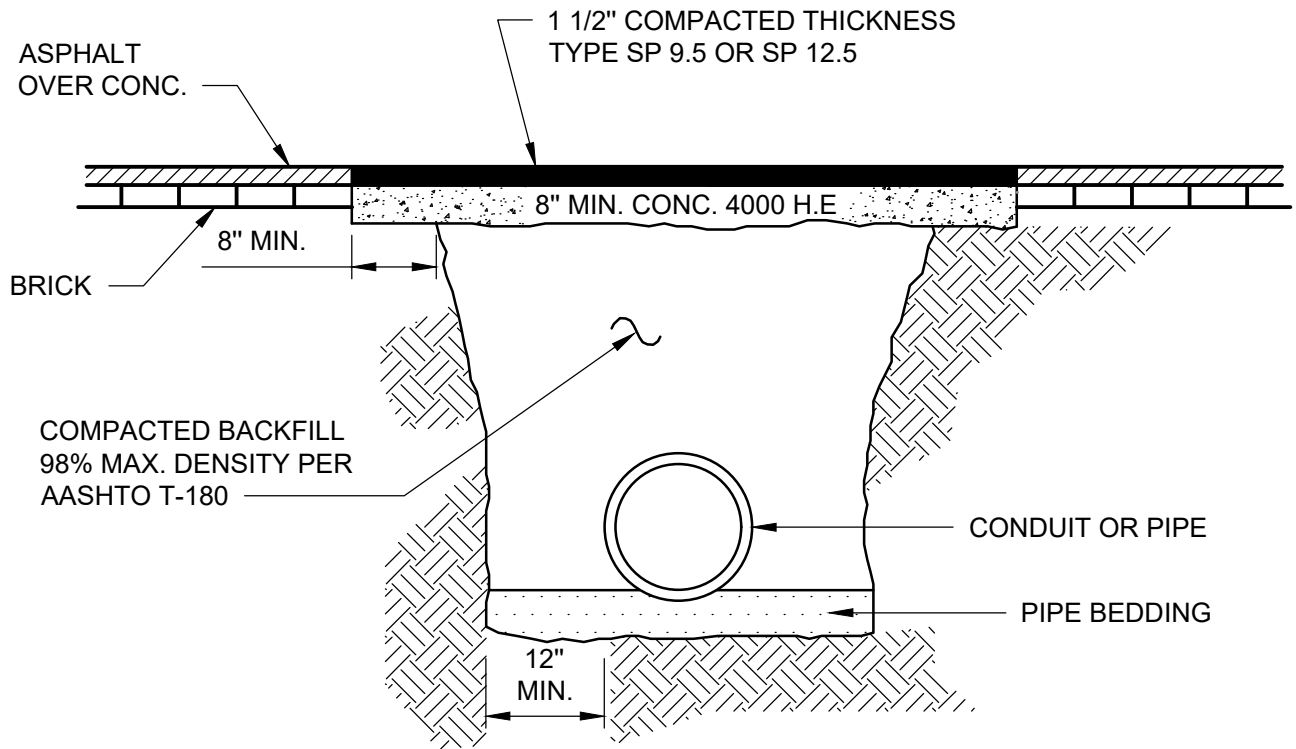

NOTE:

METHOD AND MATERIALS OF REPAIR SUBJECT TO CITY OF JACKSONVILLE
CONSTRUCTION REQUIREMENTS FOR NEW FLEXIBLE PAVEMENT.

CASE IV
STANDARD PAVING
REPAIR DETAIL

CITY OF
JACKSONVILLE
STANDARD

N.T.S.

PLATE P-405

DATE DRAWN 5/80

REVISED DATE 12-06-24

CASE V
UNPAVED ROADS

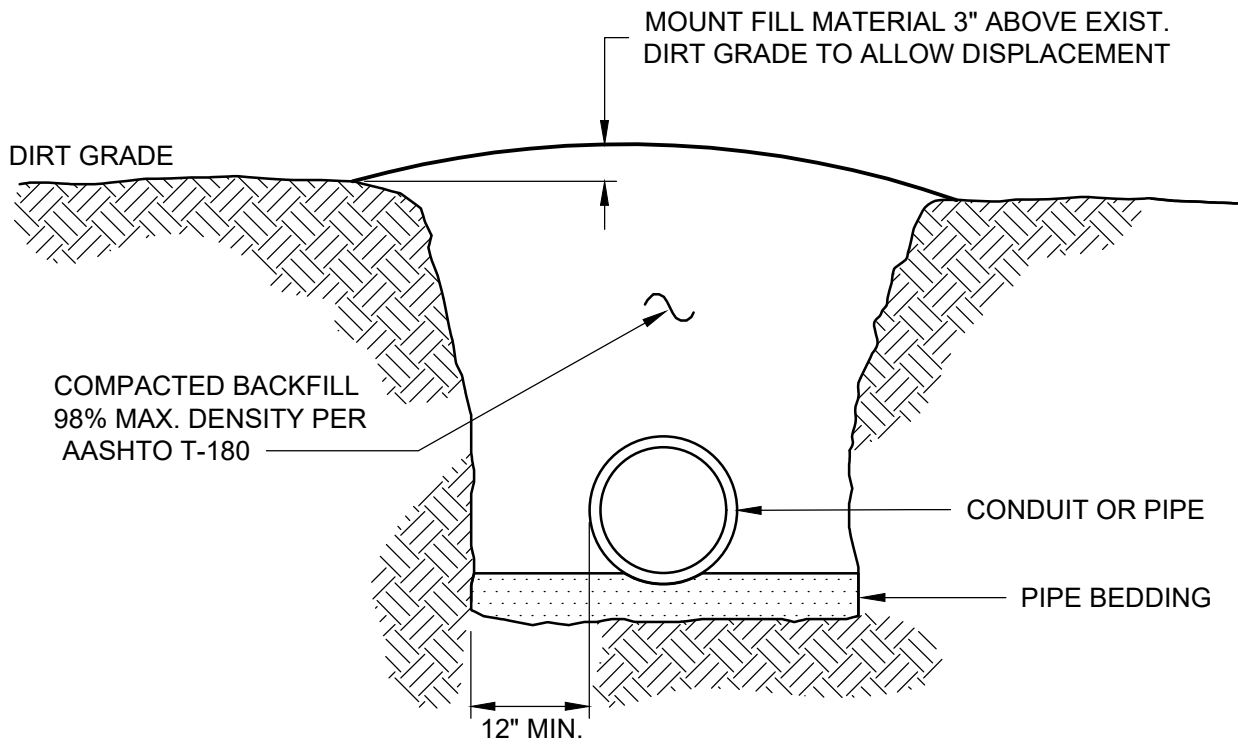

CASE V
UNPAVED ROADWAY
REPAIR DETAIL

CITY OF
JACKSONVILLE
STANDARD

N.T.S.

PLATE P-406

DATE DRAWN 4/80

REVISED DATE 12-06-24

NEW ASPHALTIC CONC. SURFACE
 COURSE TYPE SP 9.5 OR SP 12.5 1 1/2" MIN. (COMP.) THICKNESS, REPLACING EXISTING PAVEMENT.

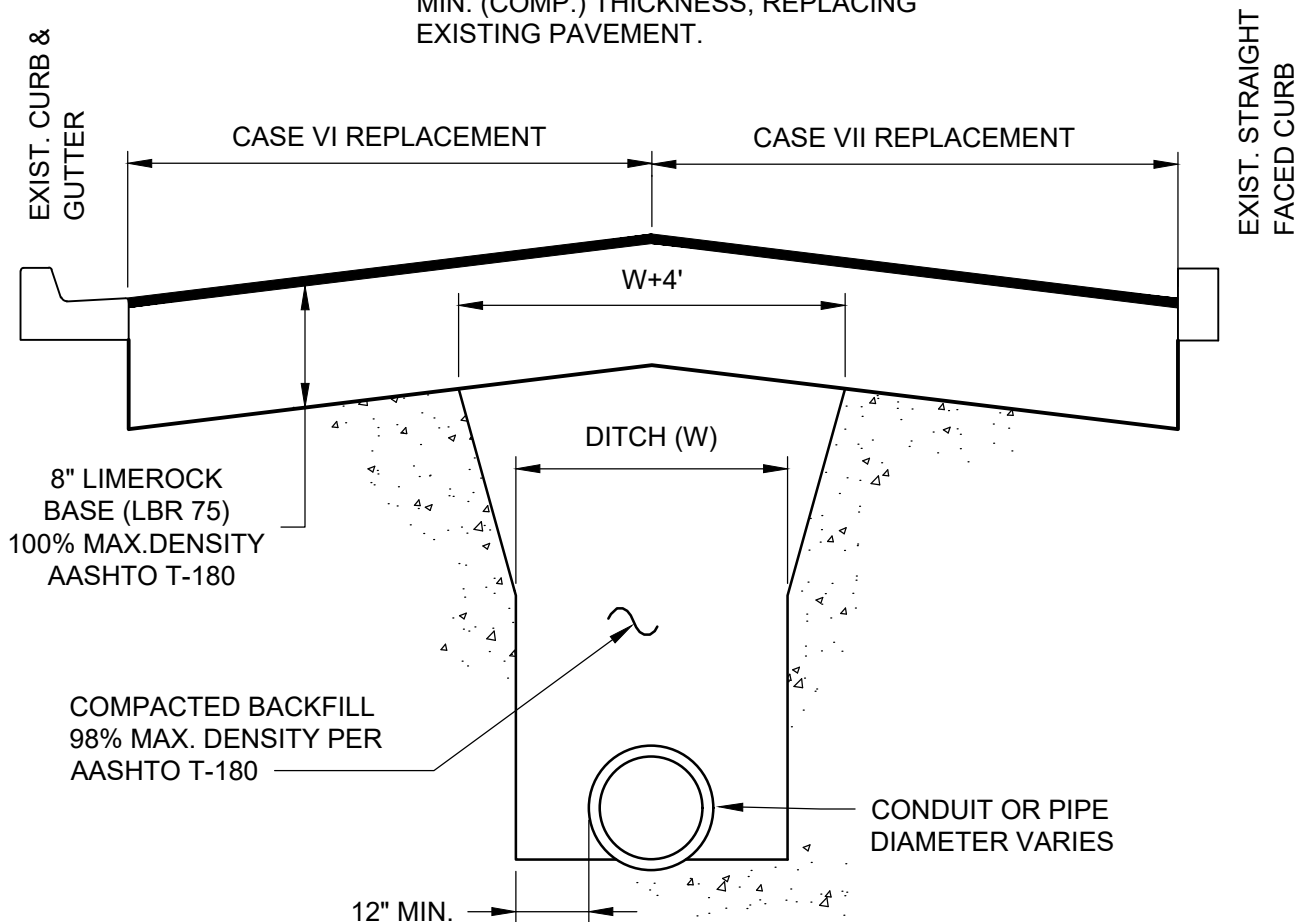

CASE VI, VII, & VIII PAVEMENT REPLACEMENT

NOTES:

1. CASE VI-A THRU VIII-A REPLACEMENT SHALL REQUIRE 2" SP 9.5 OR SP 12.5 ASPHALT SURFACE COURSE, 12" LIMEROCK (LBR 75).
2. BASE MATERIAL SHALL BE PLACED IN TWO LAYERS & EACH LAYER THOROUGHLY ROLLED OR TAMPED TO MAXIMUM DENSITY.
3. EXISTING PAVEMENT SHALL BE MECHANICALLY SAWED.
4. IN THE ABSENCE OF STRAIGHT FACED CURB OR CURB & GUTTER, THE 1 1/2" OR 2" SURFACE COURSE SHALL BE EXTENDED TO THE EDGE OF THE EXIST. PAVEMENT REMOVED (CASE VIII & VIIIA REPLACEMENT).
5. METHODS, MATERIALS, & REPAIR FOR STATE HIGHWAYS SHALL BE IN FULL COMPLIANCE WITH THE TERMS OF THE FLORIDA UTILITY PERMIT OBTAINED.
6. BACKFILL ABOVE 12" OVER TOP OF PIPE TO BE PLACED IN LAYERS NOT TO EXCEED A COMPACTED THICKNESS OF 6" WITHIN F.D.O.T. & FEDERAL R/W'S & 12" LOOSE WITHIN CITY R/W'S THEN COMPACTED.

CASE VI & VII STANDARD PAVING REPAIR DETAIL	CITY OF JACKSONVILLE STANDARD	N.T.S.	PLATE P-407
		DATE DRAWN 4/80	
		REVISED DATE 12-06-24	

CASE IX

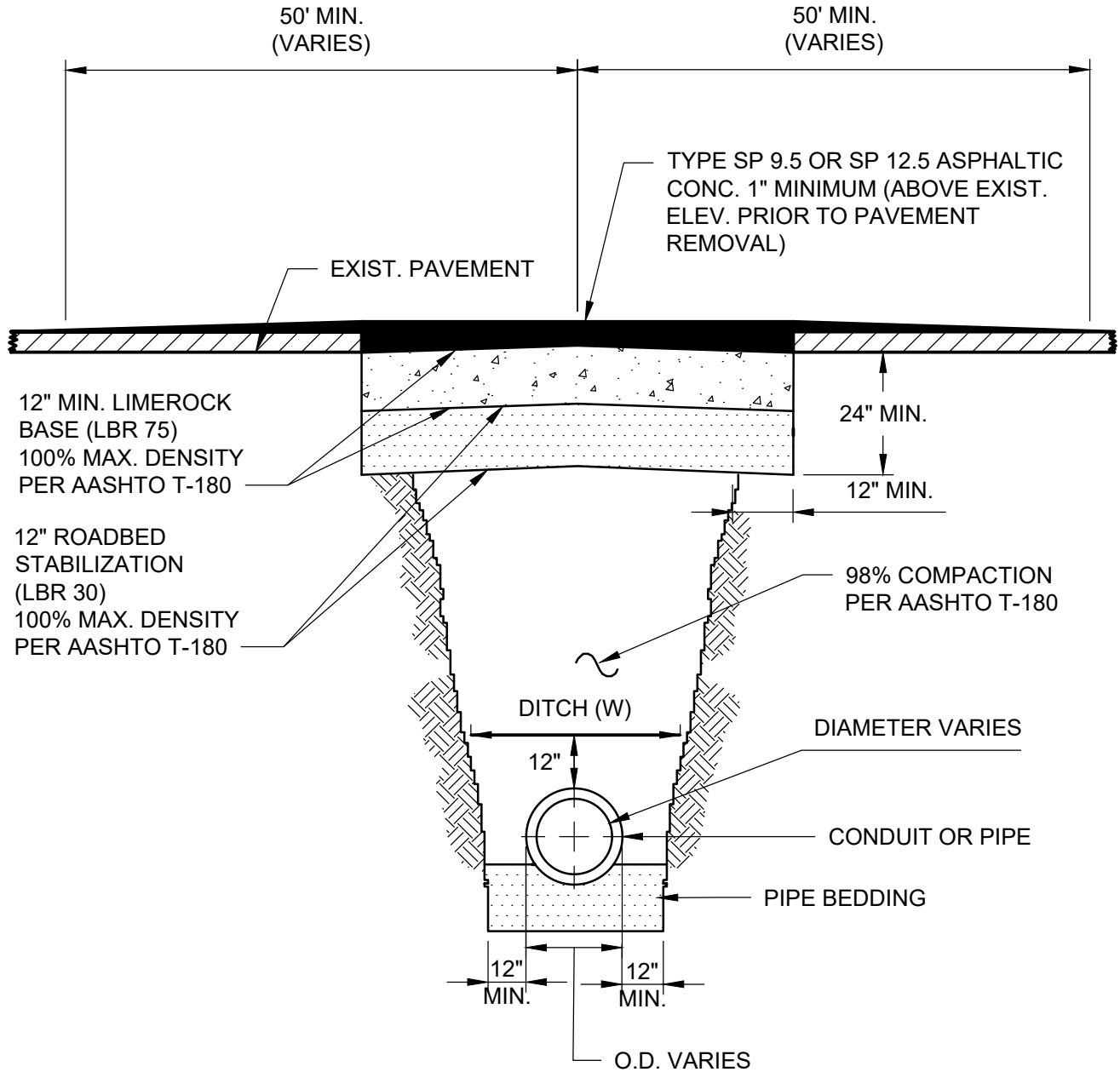

PAVEMENT REPLACEMENT

NOTE:

EXISTING PAVEMENT SHOULD BE MILLED PRIOR TO OVERLAY

CASE IX
STANDARD PAVING
REPAIR DETAIL

CITY OF
JACKSONVILLE
STANDARD

N.T.S.

PLATE P-408

DATE DRAWN APRIL., 1980

REVISED DATE 12-06-24

CASE X

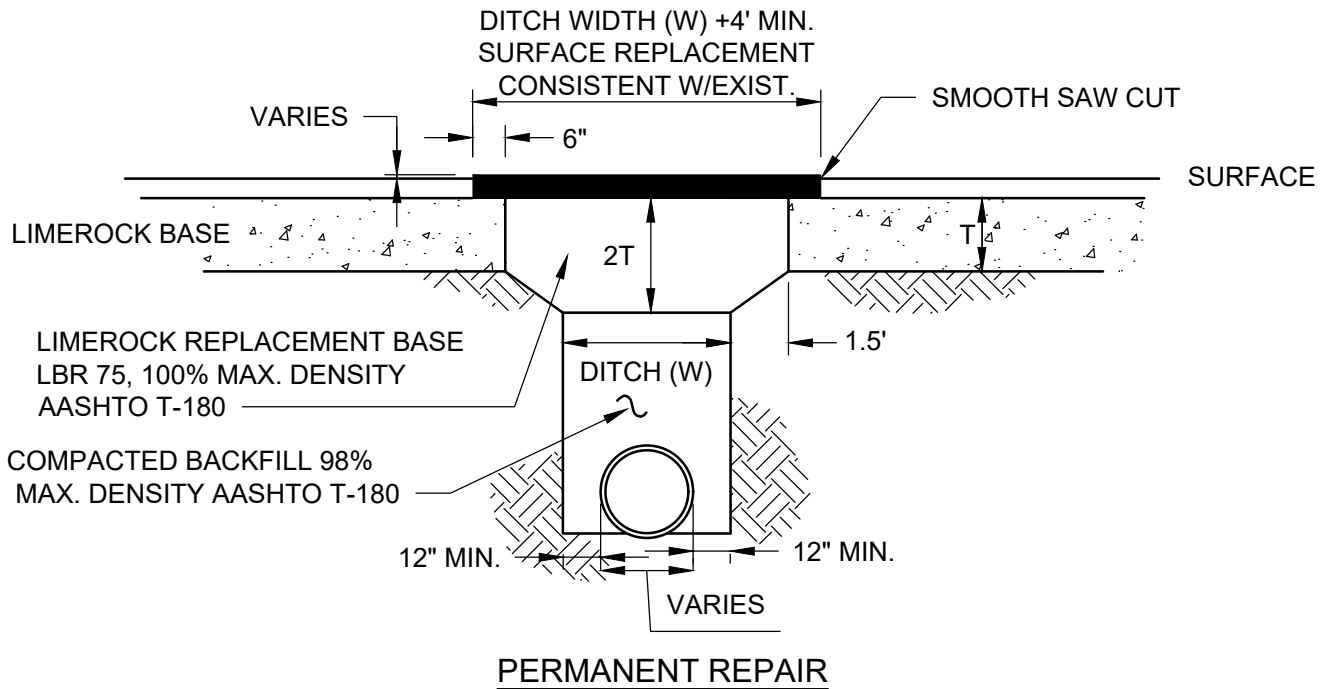
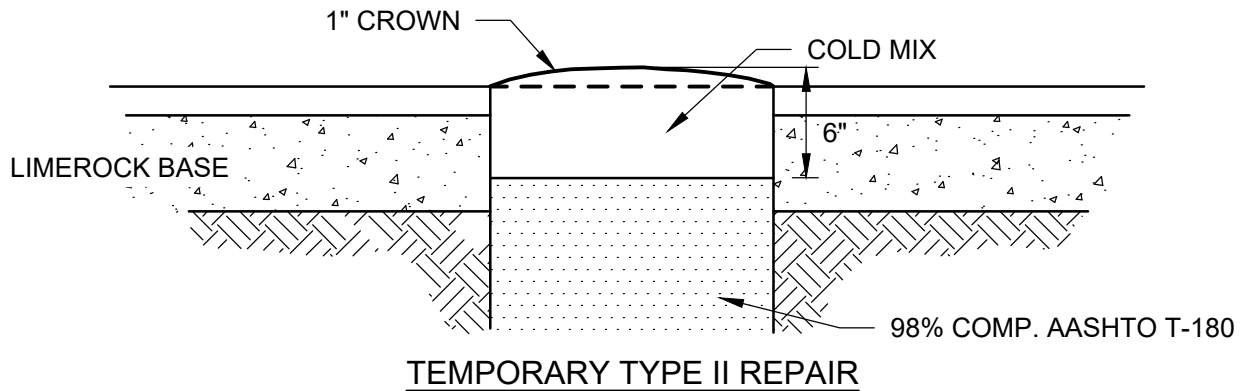
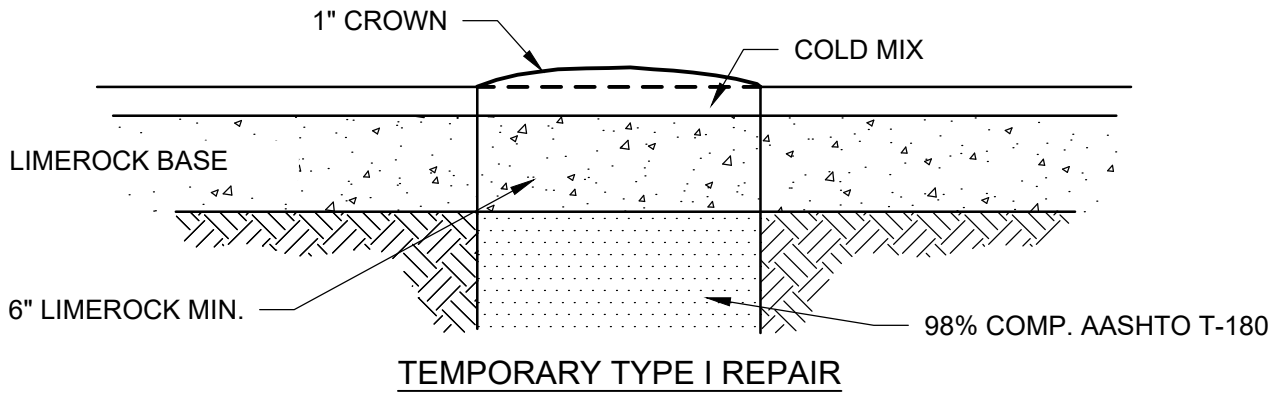

NOTE: IN SOME CASES PORTLAND CEMENT CONCRETE MAY BE CONSIDERED OR REQUIRED BY CITY ENGINEER FOR SURFACE REPLACEMENT.

CASE X
STANDARD PAVING
REPAIR DETAILS

CITY OF
JACKSONVILLE
STANDARD

N.T.S.

PLATE P-409

DATE DRAWN 07-06-73

REVISED DATE 12-06-24

CASE XI

REPLACEMENT OF P.C. CONC. CURB OR CURB & GUTTER
TO BE SAME TYPE & MATERIALS AS THAT REMOVED.

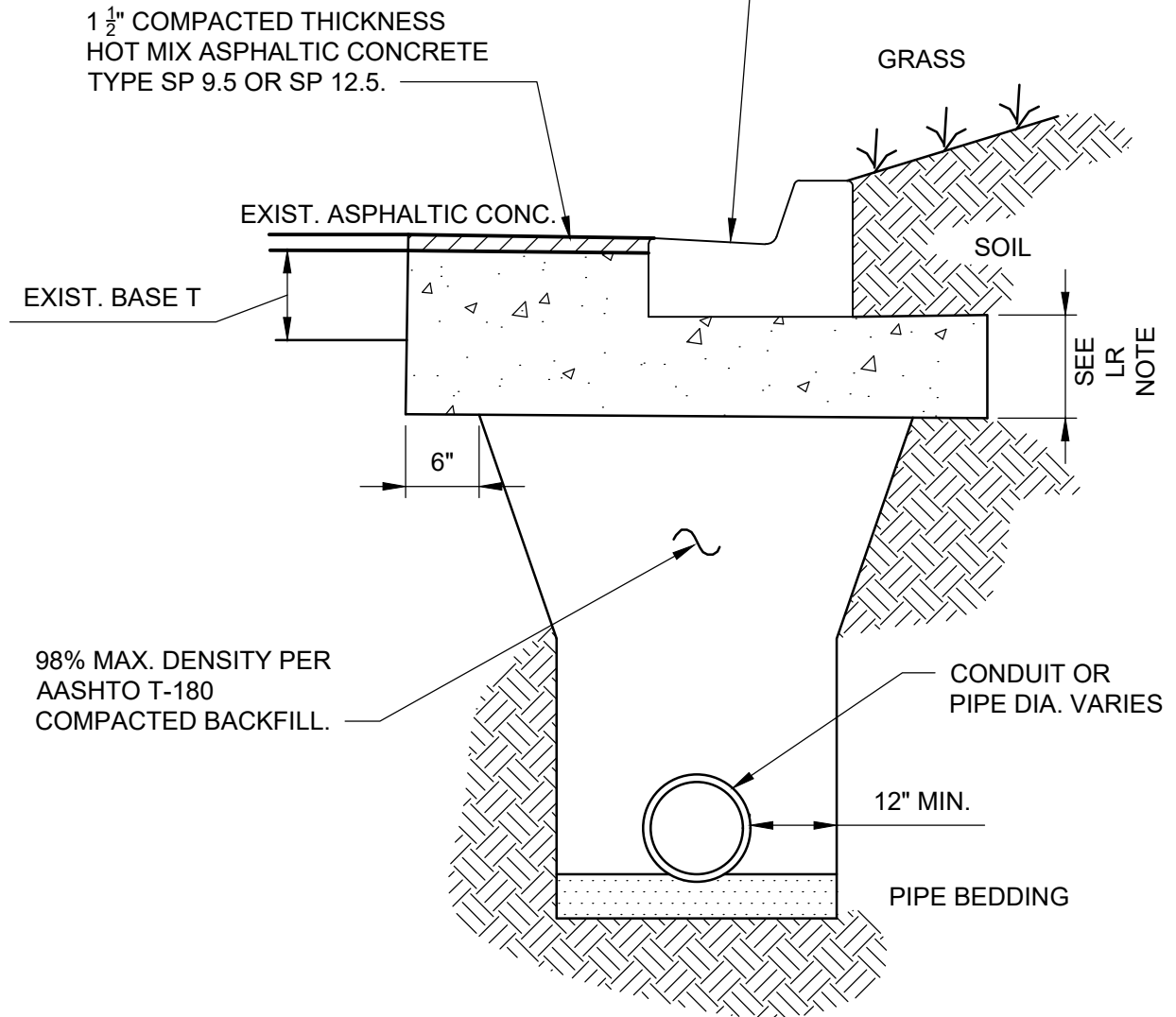

NOTES:

1. 6" MIN. OR EQUAL TO "T" ≥ 6" LIMEROCK BASE (LBR 75).
2. 100% MAX. DENSITY AASHTO T-180

CASE XI STANDARD PAVING REPAIR DETAIL	CITY OF JACKSONVILLE STANDARD	N.T.S.	PLATE P-410
		DATE DRAWN	1980
		REVISED DATE	12-06-24

CASE XII

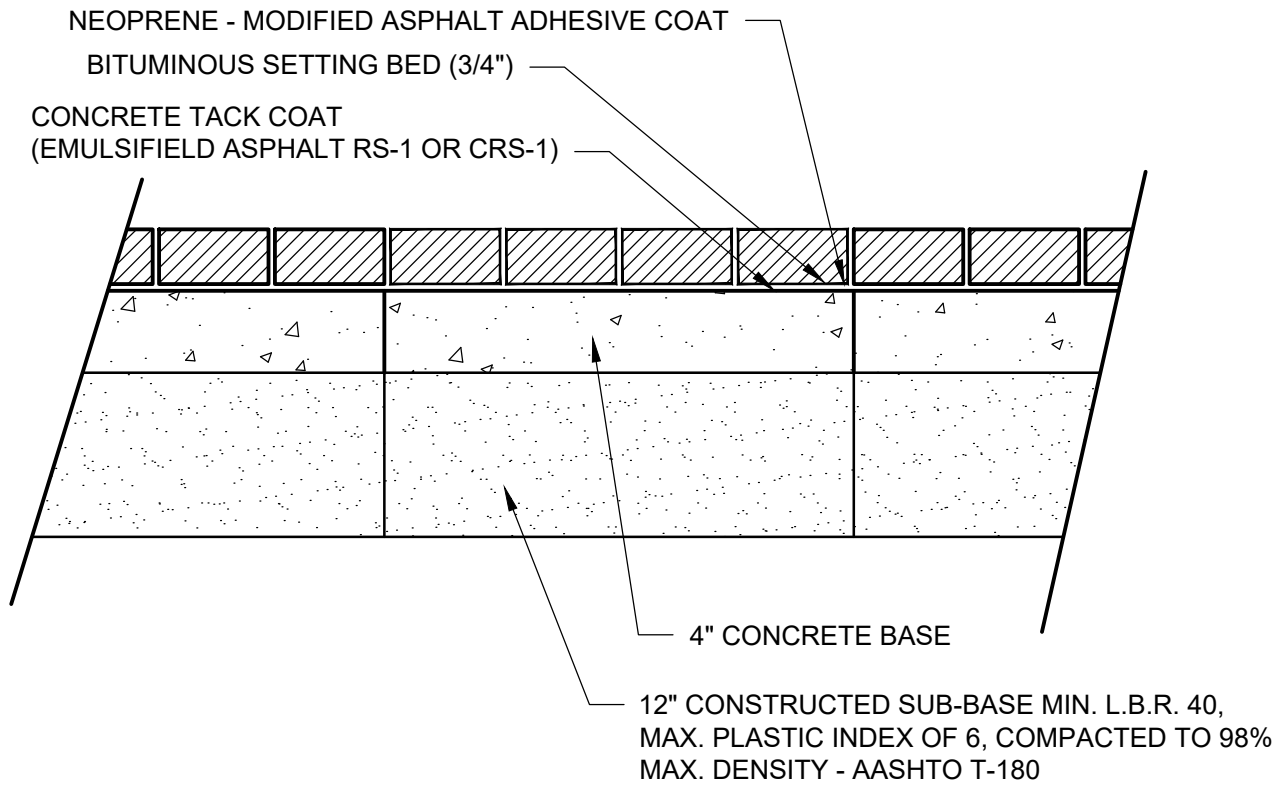
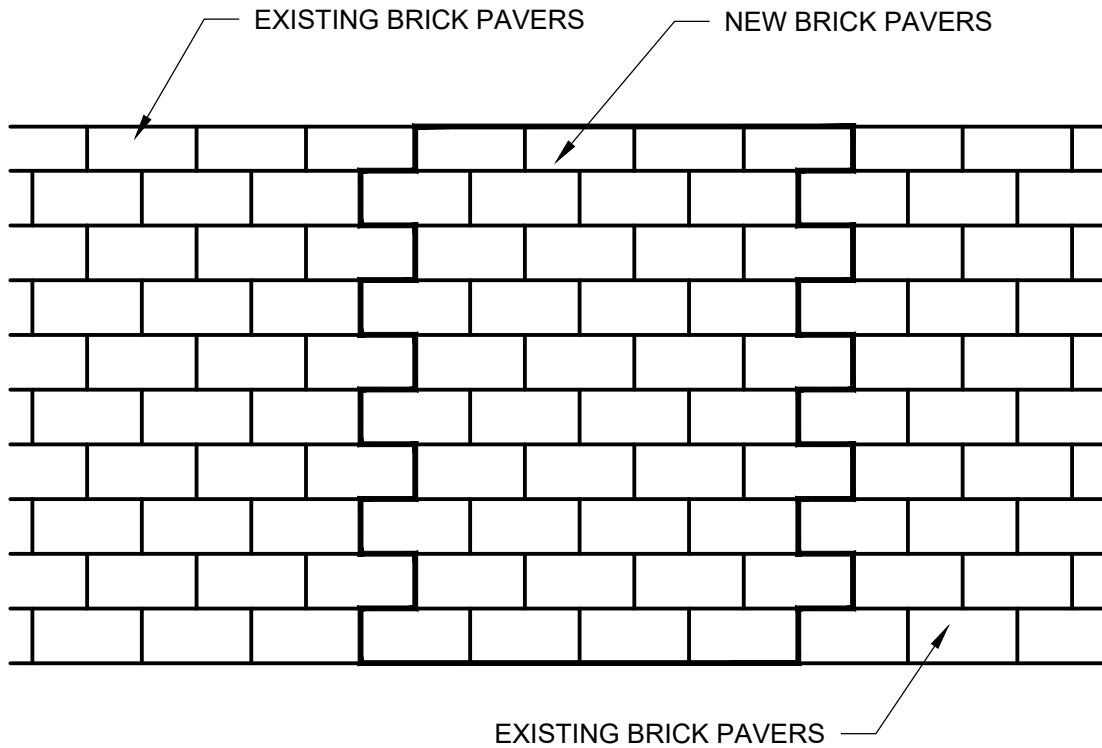

CASE XII
STANDARD BRICK STREET
REPAIR DETAIL

CITY OF
JACKSONVILLE
STANDARD

N.T.S.

PLATE P-411

DATE DRAWN 05-20-92

REVISED DATE 12-06-24

CASE XIII

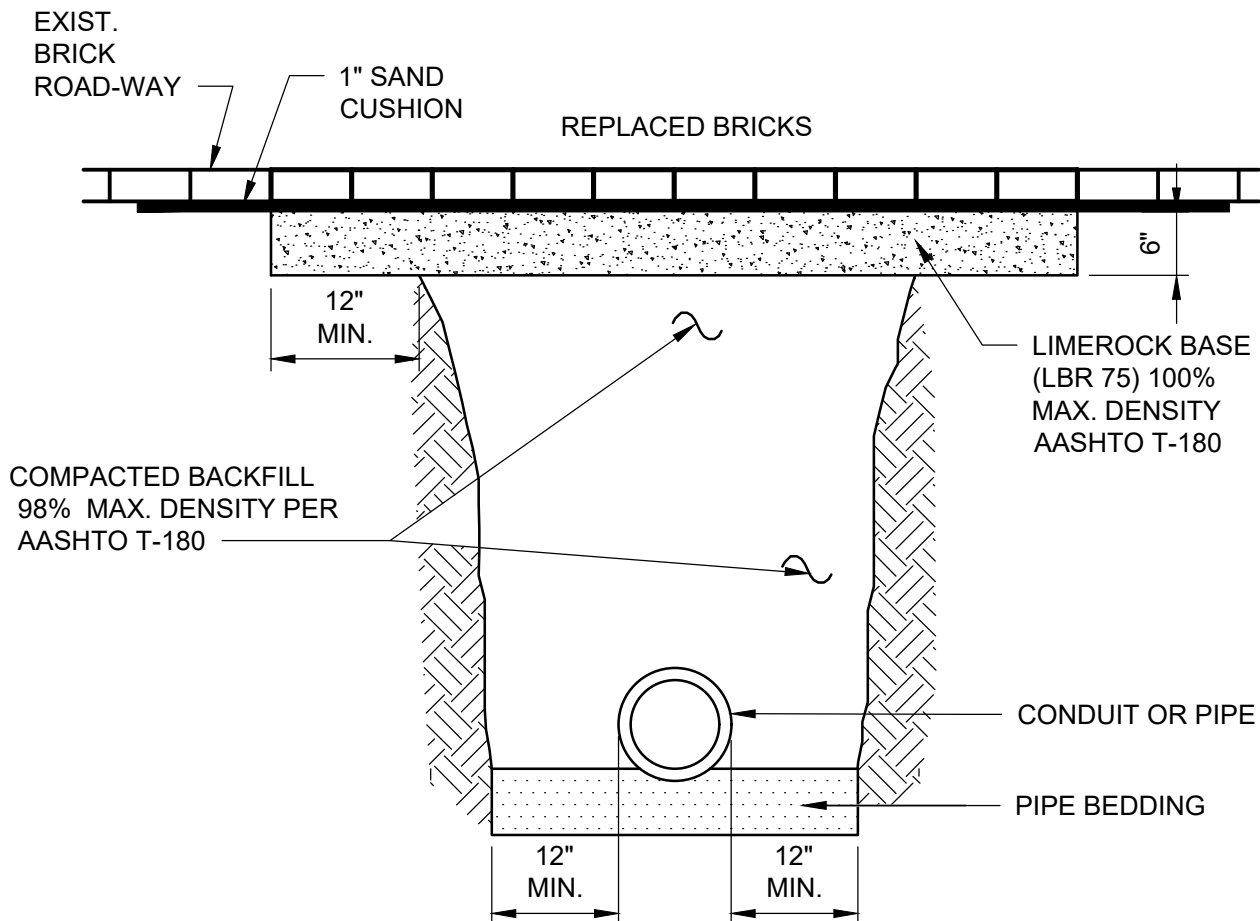

NOTE:

ALL BRICKS ARE TO BE REUSED IN EXCAVATED AREA. IF ADDITIONAL BRICKS ARE REQUIRED THEY ARE AVAILABLE IN LIMITED QUANTITIES FROM THE STREETS & DRAINAGE YARD. -Tel. No. 768-4888 - Address: 4767 Moncrief Road

CASE XIII STANDARD BRICK STREET REPAIR DETAIL	CITY OF JACKSONVILLE STANDARD	N.T.S.	PLATE P-412
		DATE DRAWN	05-20-92
		REVISED DATE	12-06-24

CASE XIV

RESTORATION OF THE EXCAVATION SHALL BE WITH EITHER FULL DEPTH ASPHALT OR ADDITIONAL COMPACTED LIMEROCK LEVEL WITH EXIST. BRICKS & 1-1/4" TYPE III ASPHALTIC CONCRETE SURFACE.

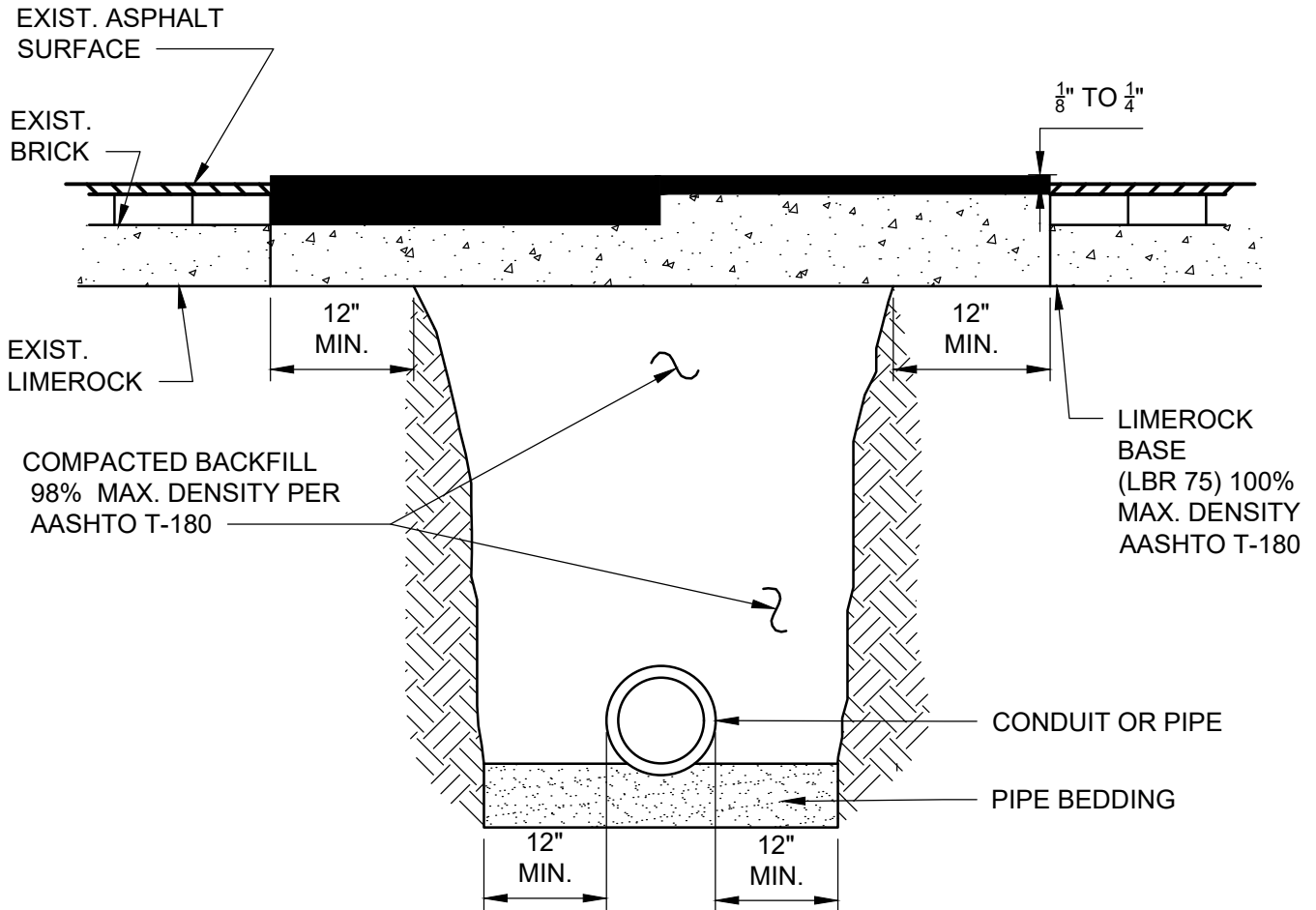

NOTE:

ALL EXIST. BRICKS NOT REUSED SHALL BE DELIVERED TO THE NORTH STREETS & DRAINAGE YARD.

CASE XIV
STANDARD BRICK STREET
REPAIR DETAIL

CITY OF
JACKSONVILLE
STANDARD

N.T.S.

PLATE P-413

DATE DRAWN DEC., 1971

REVISED DATE 12-06-24

UTILITY LOCATION GUIDELINES TND ALLEY

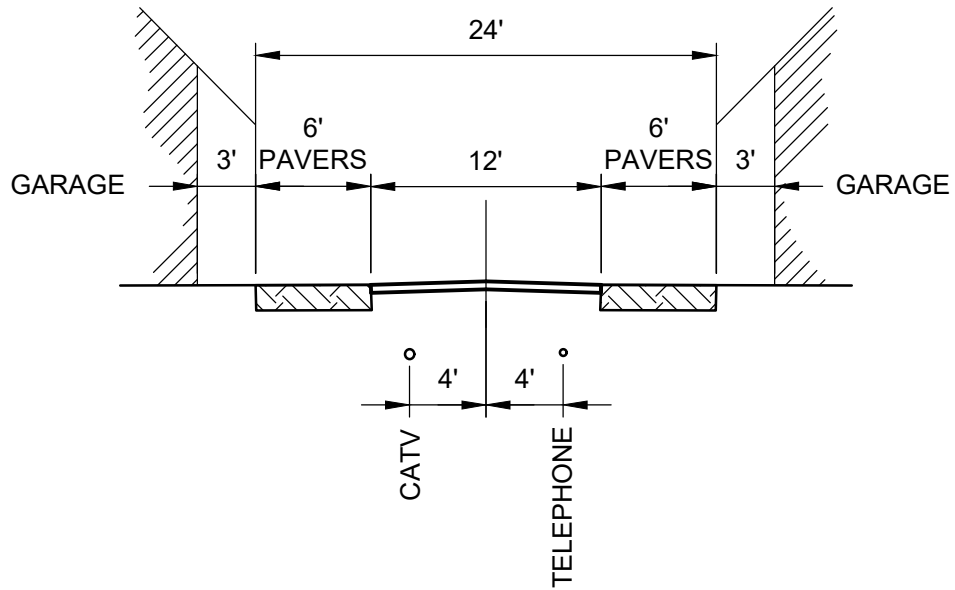

DEPTHS AT FINISHED GRADE LOCATIONS:

ELECTRIC: 42"
 RECLAIM WATER/GAS/FM/WATER/SEWER: 36"
 CATV/TELEPHONE: 18" - 24" MIN.
 SEWER SERVICE FROM R/W: 30" - 60" DEEP

TND ALLEY	CITY OF JACKSONVILLE STANDARD	N.T.S.	PLATE P-506
		DATE DRAWN	03-12-97
		REVISED DATE	12-06-24

DEPARTMENT OF PUBLIC WORKS
ENGINEERING DIVISION
DRAINAGE STANDARD SECTION
INDEX

Series 100 MANHOLES

D-101 Stormwater Type J-1 Thru J-1-F Manhole
D-102 Stormwater Type J-2 Manhole
D-103 Stormwater Type J-3 Manhole
D-104 Stormwater Type J-4 Manhole
D-105 Stormwater Type J-5 Manhole
D-106 Storm Sewer Cast-in-Place Manhole
D-107 Notes for Manholes & Inlets
D-108 Slab Design Square and Rectangular Structures
D-109 Wall Designs Rectangular Structures
D-110 Slab Design Round Structures

Series 200 INLETS

D-201 Curb Inlet
D-202 Standard Curb Inlet Installation
D-203 48" I.D. Curb Inlet
D-204 Double and Triple Curb Inlet
D-205 Type "B" Inlet
D-206 Double Type "B" Inlet
D-207 Type "C" Inlet
D-208 Type "E" Inlet
D-209 Detail for Type "C & E" Inlet
D-210 Eye Bolt and Chain for Locking Grates to Inlet
D-211 Sand Trap Basic
D-212 Invert Detail

Series 300 CASTINGS

D-301 Storm Sewer Manhole Cover and Frame
D-302 Storm Sewer Curb Inlet Frame
D-303 Storm Sewer Curb Iron
D-304 Storm Sewer Inlet Grate
D-305 Storm Sewer Catch Basin Frame
D-306 Curb Iron with Grate & Frame
D-307 Grate Detail for Type "E" Inlet
D-308 M/H Cover Detail

Series 400 ENDWALLS

D-401 Straight Concrete Endwalls – Single and Multiple Pipe
D-402 Straight Concrete Endwalls – Single and Multiple Pipe
D-403 Straight Concrete Endwalls – Single and Multiple Pipe
D-404 Straight Concrete Endwalls – Single and Multiple Pipe

D-405 Straight Concrete Endwalls – Single and Multiple Pipe
D-406 Straight Endwall for 60" – 78" Concrete Pipe Culverts
D-407 Dimensional and Quantitative Data for 60" – 78" Concrete Pipe Endwalls
D-408 Concrete Endwall with 45° Wings for Pipe Culverts
D-409 Concrete Endwall with U-Type Wings for Pipe Culverts
D-410 Flared End Section for Pipe Culverts
D-411 Sand – Cement Rip Rap Endwall
D-412 Concrete Endwall for Multiple 60" – 78" Round Pipes
D-413 Dimensional and Quantitative Data for Multiple 60" – 78" Concrete Pipe Endwalls
D-414 Straight Endwall for Single Precast Concrete Box Culvert
D-415 Straight Endwall for Double Precast Concrete Box Culvert
D-416 Straight Endwall for Triple Precast Concrete Box Culverts
D-417 Sections of Endwall for 4' High Single, Double, & Triple Precast Culverts
D-418 Sections of Endwall for 5' High Single, Double, & Triple Precast Culverts
D-419 Sections of Endwall for 6' High Single, Double, & Triple Precast Culverts
D-420 Bar Bending Diagram for Steel in Endwall for Single, Double, and Triple Precast Box Culverts
D-421 Dimensional & Quantitative Data for Single Box Culvert Endwalls
D-422 Dimensional & Quantitative Data for Single Box Culvert Endwalls
D-423 Dimensional & Quantitative Data for Single Box Culvert Endwalls
D-424 Dimensional & Quantitative Data for Double Box Culvert Endwalls
D-425 Dimensional & Quantitative Data for Double Box Culvert Endwalls
D-426 Dimensional & Quantitative Data for Double Box Culvert Endwalls
D-427 Dimensional & Quantitative Data for Triple Box Culvert Endwalls
D-428 Concrete Endwall with L-Type Wing for Pipe Culverts
D-429 Precast Mitered End for Driveway Culverts
D-430 Precast Mitered End for Elliptical Driveway Culverts
D-431 Standard Mitered End Section for RCP or CMP
D-432 Standard Table of Dimensions for Mitered End Section
D-433 Standard Flared End Sections for Corrugated Metal Pipe
D-434 Flared End Sections Dimensional Data for Corrugated Metal Pipe
D-435 Mitered End Section for R.C.P or E.R.C.P. Cross Drain Type B
D-436 Connector Detail for Mitered End Section
D-437 Tables of Dimension for Mitered End Sections Type B
D-438 CMP or CMPA Mitered End Section Detail

Series 500 DITCH PAVING

D-501 Concrete Ditch Paving and Weep Hole Arrangement
D-502 Alternate Weephole Detail

Series 600 CHECK DAM

D-601 Temporary Sand-Cement Rip Rap Check Dam
D-602 Concrete Check Dam

Series 700 UNDERDRAIN

D-701 Underdrain Installation Type I
D-702 Underdrain Installation Type II

D-703 Underdrain Installation Type III
D-704 Underdrain Cleanout Detail
D-705 Paved Outfall for Underdrain
D-706 Prefabricated Edge Drain Detail

Series 800 PIPE BEDDING

D-801 Pipe Bedding Case 1
D-802 Pipe Bedding Case 2
D-803 Pipe Bedding Case 3
D-804 Culvert Placement with Less than 12" Cover

Series 900 EROSION & SEDIMENT CONTROL

D-901 Bale Location
D-902 Block and Gravel Curb Inlet Sediment Filter
D-903 Gravel Inlet Sediment Trap
D-904 Block and Gravel Drop Inlet Sediment Filter
D-905 Drop Inlet Sediment Filter
D-906 Spacing Recommendation for Silt Fences
D-907 Turbidity Barriers
D-908 Silt Fence Type II & IV
D-909 Construction Details for Silt Fences
D-910 Filter Barrier Construction Detail
D-911 Staked Bale
D-912 Bale Barriers Type I & II
D-913 Bale Barrier Construction Details
D-914 Diversion Dike
D-915 Plant Materials Temporary Seeding
D-916 Seeding Mixtures, Rates and Dates

Series 1000 STORMWATER PONDS

D-1001 Detention Pond Detail Case 1
D-1002 Detention Pond Detail Case 2 & 3
D-1003 Detention Pond Detail Case 4
D-1004 Detention Pond Detail Case 5

COVER

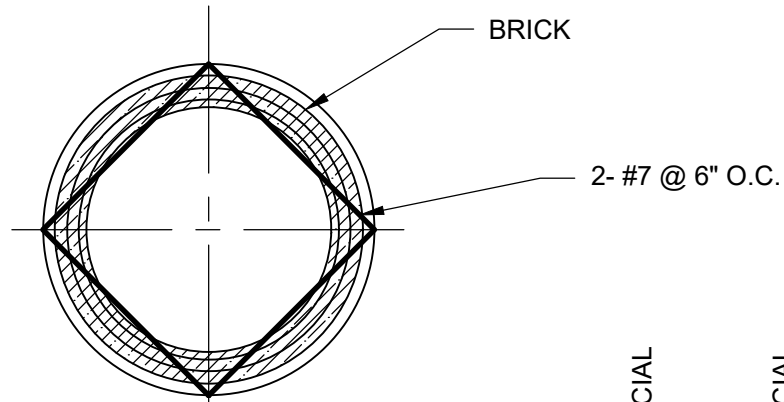

PLAN

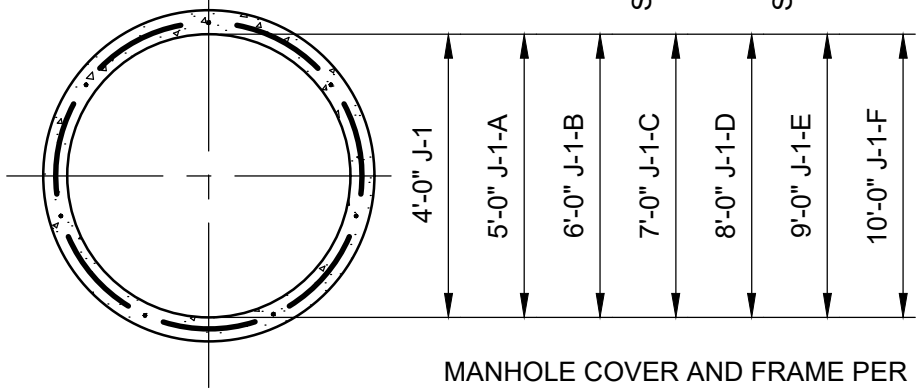

PRECAST IN ACCORDANCE WITH LATEST EDITIONS OF ASTM C 478.

MANHOLE COVER AND FRAME PER CITY OF JAX. STD. PLATE D-301.

PIPE MUST NOT BE IN CONST. JOINT.

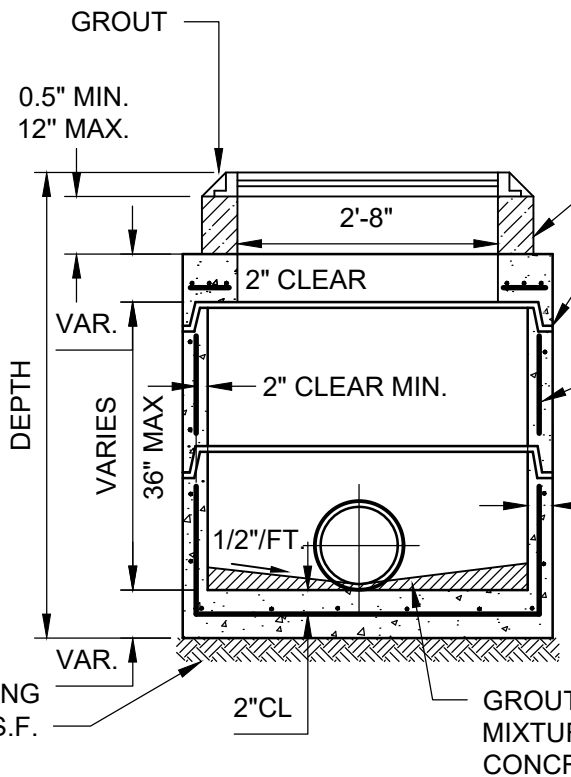

MINIMUM WALL THICKNESS SHALL BE ONE TWELFTH OF THE DIAM. PLUS 1 INCH OF THE RISER, WITH A MINIMUM WALL THICKNESS OF 5".

PIPES SHALL BE FLUSH WITH INSIDE WALL.

NOTE: FOR ADDITIONAL STRUCTURAL DETAILS REFER TO PLATE D-110.

STORMWATER TYPE J-1 THRU J-1-F MANHOLE	CITY OF JACKSONVILLE STANDARD	N.T.S.	PLATE D-101
		DATE DRAWN	AUG. 1979
		REVISED DATE	7-2-24

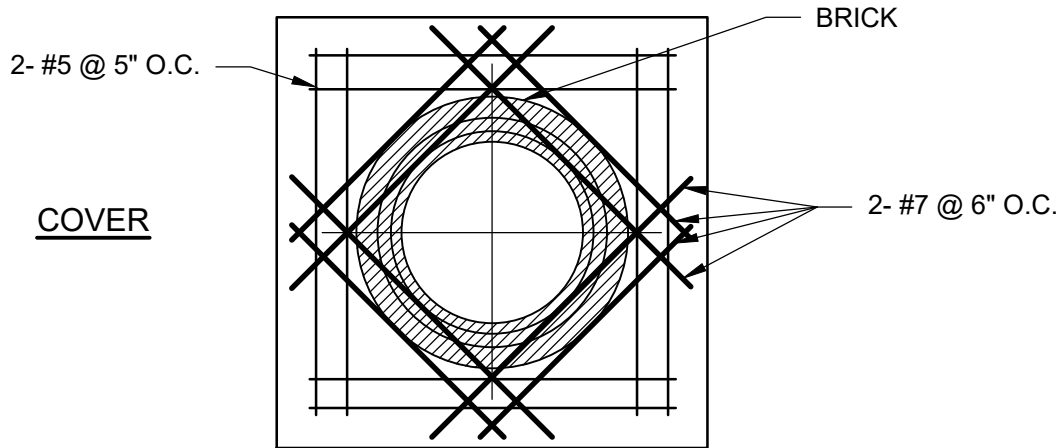

PLAN

MANHOLE COVER & FRAME PER CITY OF JAX. STD. PLATE D-301.

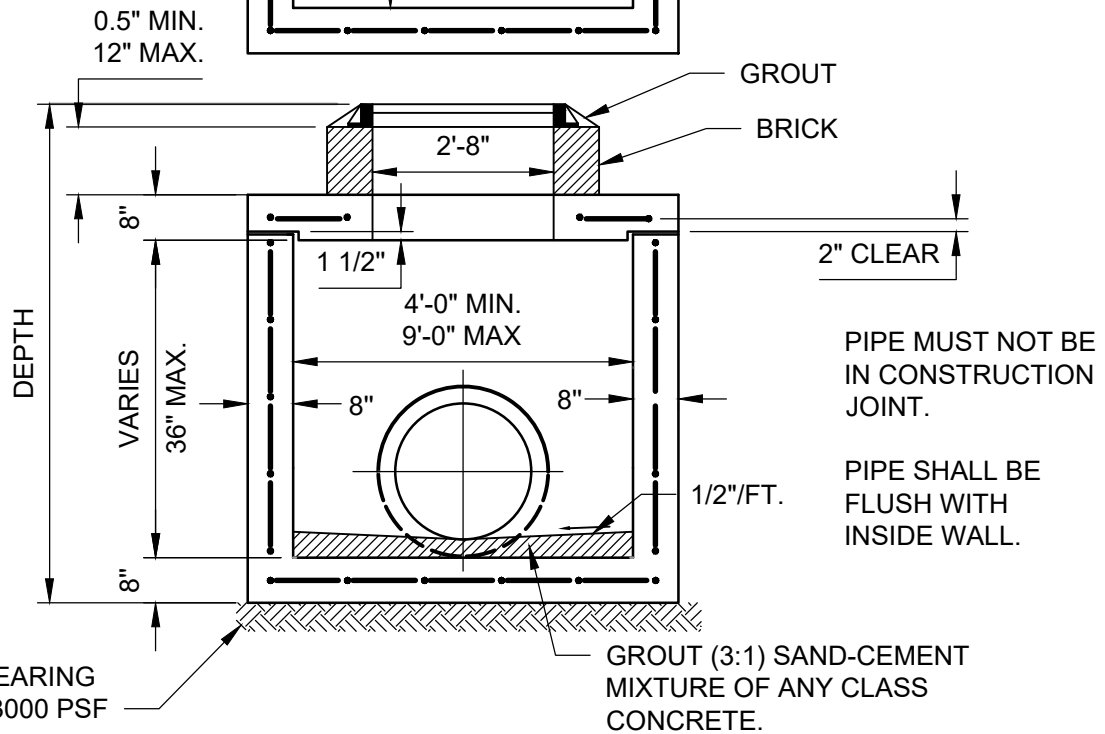
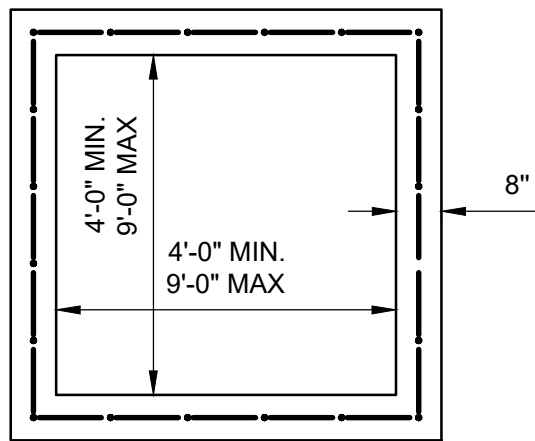

NOTE: FOR ADDITIONAL STRUCTURAL DETAIL REFER TO PLATES D-107, D-108, & D-109

STORMWATER TYPE
J-2 MANHOLE

CITY OF
JACKSONVILLE
STANDARD

N.T.S.

PLATE D-102

DATE DRAWN 1-31-89

REVISED DATE 7-2-24

PLAN

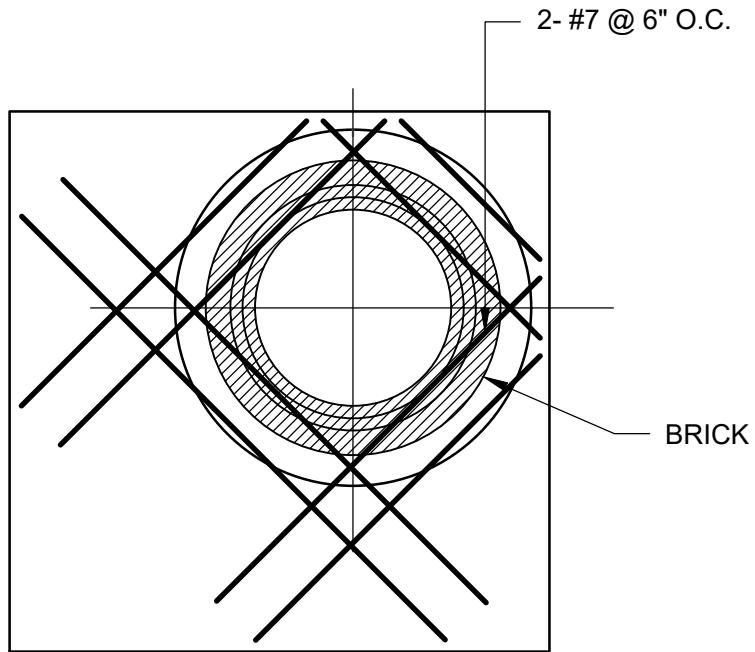

MANHOLE COVER AND
FRAME PER CITY OF JAX.
STD. PLATE D-301.

RISER SECTION PRECAST
IN ACCORDANCE WITH
LATEST EDITION OF
A.S.T.M. C478.

GROUT, "RAM-NEK" OR
"O-RING" JOINTS

PIPE MUST NOT BE IN
CONSTRUCTION JOINT.

PIPES SHALL BE FLUSH
WITH INSIDE WALL.

MIN. BEARING
CAPACITY 3000 PSF

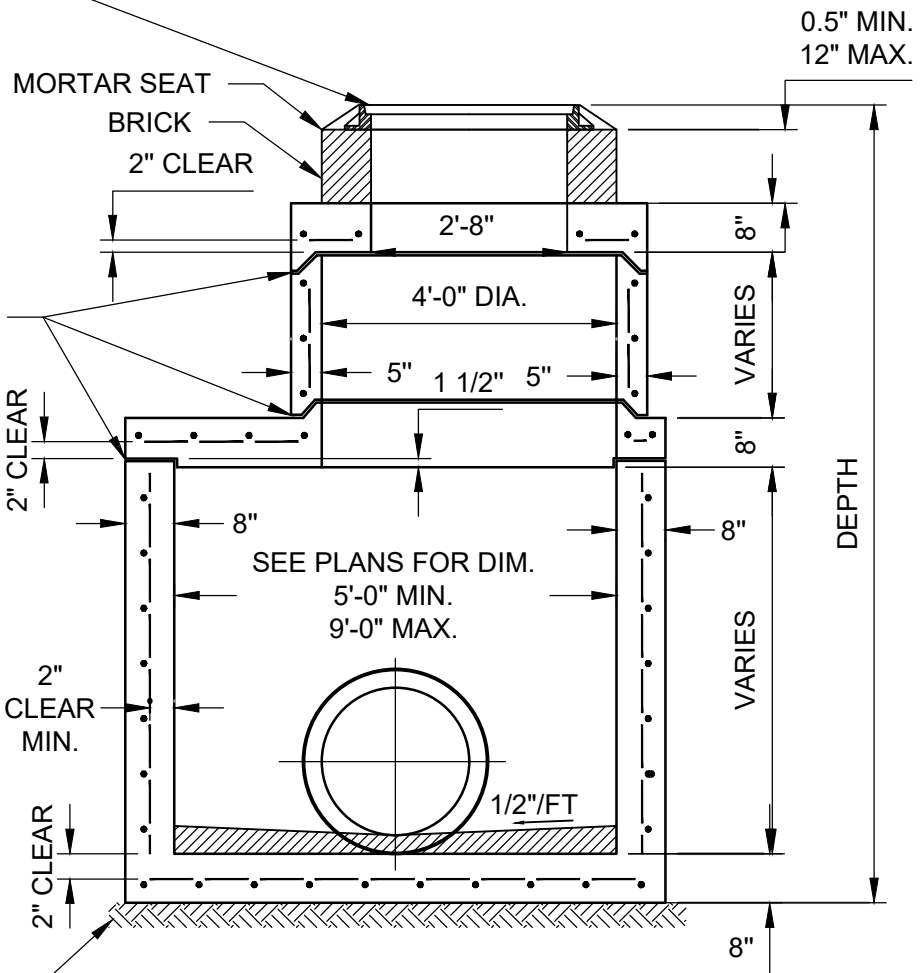

NOTE: FOR ADDITIONAL STRUCTURAL DETAILS REFER TO PLATE D-107, D-108, D-109, & D-110

STORMWATER TYPE J-3 MANHOLE	CITY OF JACKSONVILLE STANDARD	N.T.S.	PLATE D-103
		DATE DRAWN	8-3-79
		REVISED DATE	7-2-24

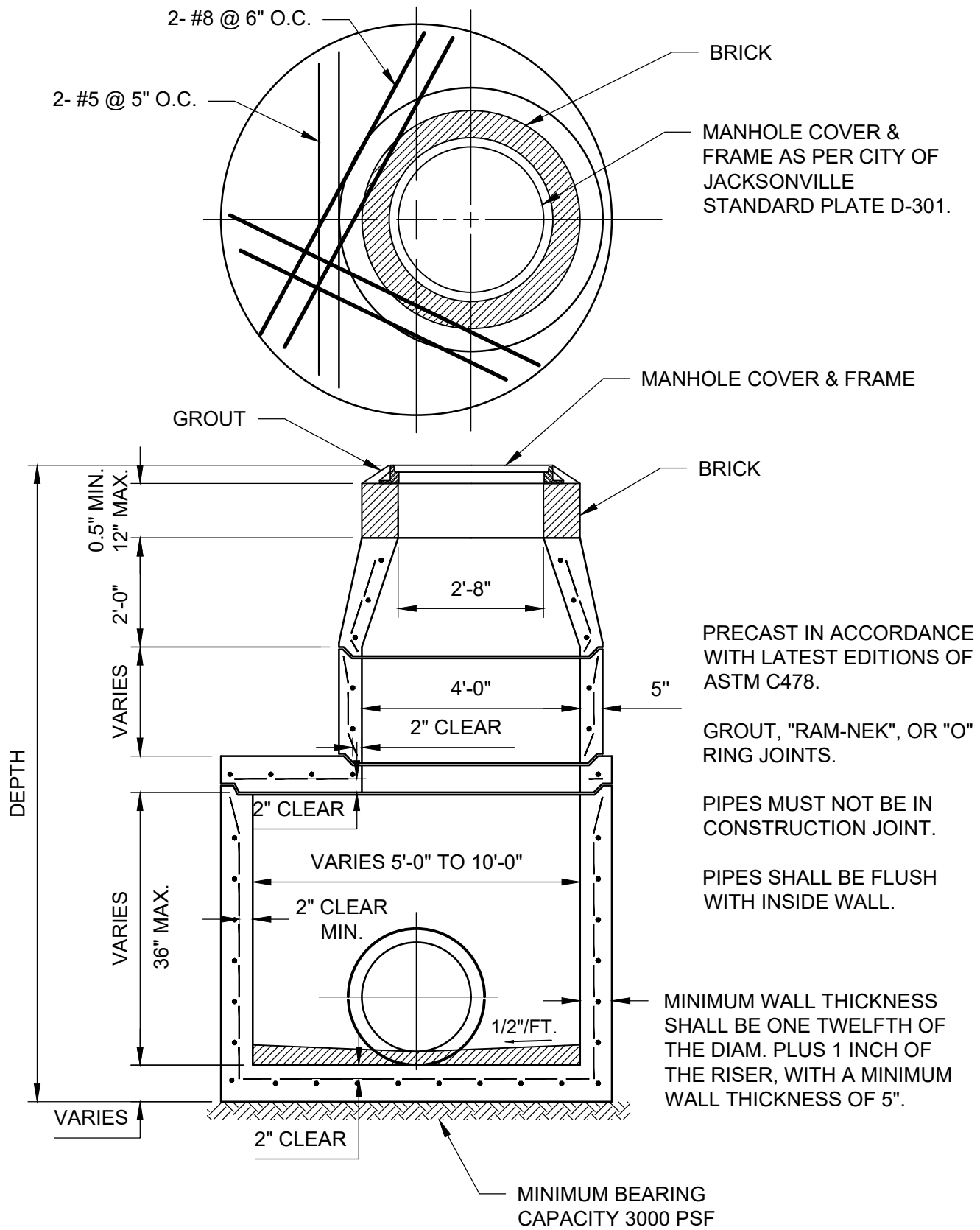

NOTE: FOR ADDITIONAL STRUCTURAL DETAIL REFER TO PLATE D-110.

STORMWATER TYPE J-4 MANHOLE	CITY OF JACKSONVILLE STANDARD	N.T.S.	PLATE D-104
		DATE DRAWN	2-10-79
		REVISED DATE	7-2-24

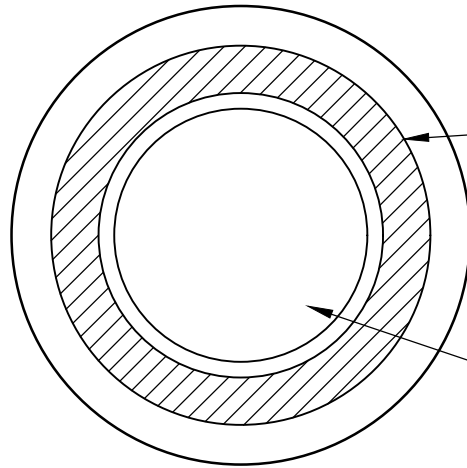

BRICK

NOTE: CONC. DESIGN STRENGTH 4000 PSI

MANHOLE TOP/FRAME PER CITY OF JAX. STD. PLATE D-301.

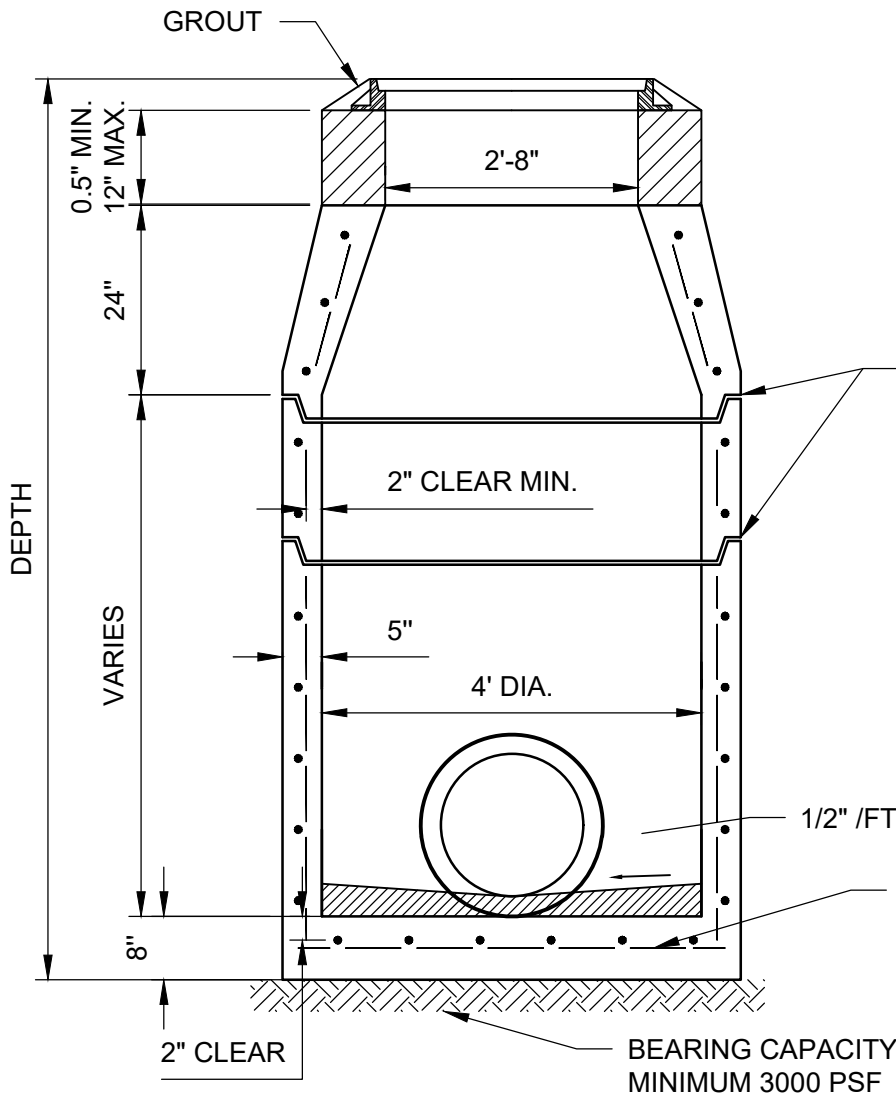

PRECAST IN ACCORDANCE WITH LATEST EDITIONS OF ASTM C478.

GROUTED, OR "RAM-NEK", OR "O RING" JOINTS.

MAX. SERVICE LINES: 24" RCP THRU 180° 18" RCP THRU DOWN TO 90°

PIPES MUST NOT BE IN CONSTRUCTION JOINT.

PIPES SHALL BE FLUSH WITH INSIDE WALL.

REINFORCE BOTTOM WITH #4 @ 9" O.C. B.W.

BEARING CAPACITY MINIMUM 3000 PSF

NOTE: FOR ADDITIONAL STRUCTURAL DETAIL REFER TO PLATE D-110

STORMWATER TYPE J-5 MANHOLE

CITY OF JACKSONVILLE STANDARD

N.T.S.

PLATE D-105

DATE DRAWN 2-15-89

REVISED DATE 7-2-24

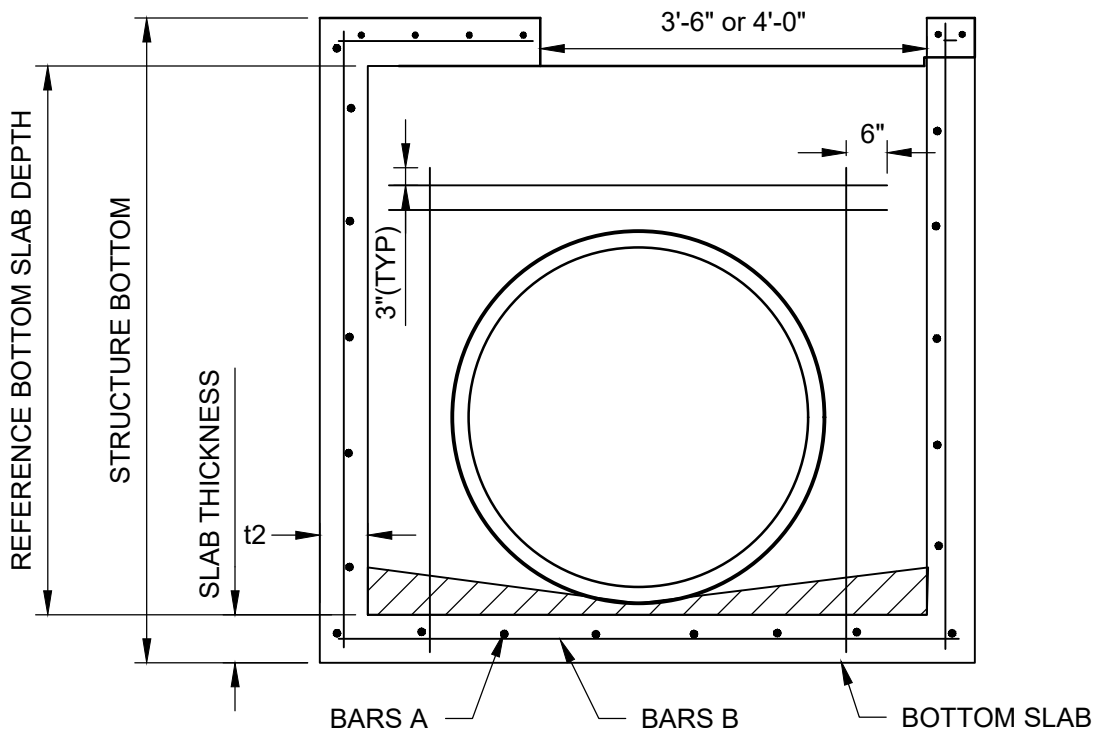

NOTES:

1. REFER TO FDOT STANDARD PLANS INDEX 425-010 FOR REQUIREMENTS OF CAST-IN-PLACE MANHOLE BOX.
2. MANHOLES OVER 10' DEEP SHALL HAVE 12" WALL THICKNESS FOR ALL PORTIONS OF WALL OVER 10' DEEP.
3. MANHOLE COVER AND FRAME PER CITY OF JACKSONVILLE STANDARD.
4. BOTTOM SLAB TO BE 4000 P.S.I. CLASS "A" CONCRETE.

STORM SEWER CAST
IN PLACE MANHOLE

CITY OF
JACKSONVILLE
STANDARD

N.T.S.

PLATE D-106

DATE DRAWN 2-15-79

REVISED DATE 12-19-24

1. FOR SQUARE OR RECTANGULAR PRECAST DRAINAGE STRUCTURES, EITHER DEFORMED OR SMOOTH WELDED WIRE FABRIC MAY BE USED PROVIDED:
 - a) THE SMOOTH WELDED WIRE FABRIC SHALL COMPLY WITH ASTM A-185, AND DEFORMED WELDED WIRE FABRIC SHALL COMPLY WITH ASTM A-497.
 - b) WIDTH AND LENGTH OF THE UNIT IS FOUR TIMES THE SPACING OF THE CROSS WIRES.
 - c) WIRE FABRIC SHALL BE CONTINUOUS AROUND THE BOX, SPLICED AT QUARTER POINT(S) WITH OVERLAP OF NOT LESS THAN THE SPACING OF THE CROSS WIRES PLUS TWO INCHES.
2. HORIZONTAL STEEL IN THE WALLS OF RECTANGLES STRUCTURES SHALL BE LAPPED A MINIMUM OF 24 BAR DIAMETER AT CORNERS.
3. WELDING OF SPLICES AND LAPS IS PERMITTED. THE REQUIREMENTS AND RESTRICTIONS PLACED ON WELDING IN AASHTO M-259 SHALL APPLY.
4. REBAR STRAIGHT END EMBEDMENT OR PERIPHERAL REINFORCEMENT MAY BE USED IN LIEU OF ACI STANDARD HOOKS FOR TOP AND BOTTOM SLABS EXCEPT WHEN HOOKS ARE SPECIFICALLY CALLED FOR IN PLANS OR STANDARD DRAWINGS.
5. CONCRETE WHICH MEETS THE REQUIREMENTS OF ASTM C-478 SHALL BE USED FOR STRUCTURES CONSTRUCTED TO THESE DETAILS.
6. REINFORCEMENT CAN BE EITHER DEFORMED BAR REINFORCEMENT OR WELDED WIRE FABRIC. BAR REINFORCEMENT OTHER THAN 40 KSI MAY BE USED, HOWEVER ONLY TWO GRADES ARE RECOGNIZED: GRADE 40 AND GRADE 60. WELDED WIRE FABRIC, INCLUDING SMOOTH AND DEFORMED WELDED WIRE FABRIC, WILL BE RECOGNIZED AS HAVING A DESIGN STRENGTH OF 65 KSI AND 70 KSI RESPECTIVELY. THE AREA OF REINFORCEMENT REQUIRED MAY BE REDUCED IN ACCORDANCE WITH THE EQUIVALENT STEEL AREA TABLE PROVIDED. FOR BARS AND SPACING NOT GIVEN, THE STEEL AREA REQUIRED CAN BE DETERMINED BY THE FOLLOWING EQUATIONS:

$$\text{GRADE 60 STEEL AREA} = \text{AS } 60 = 40\text{K}/60\text{K} \times \text{AS } 40$$

$$\text{WELDED WIRE FABRIC STEEL AREA} = \text{AS } 65 = 40\text{K}/65\text{K} \times \text{AS } 40$$

IN NO CASE WILL FABRIC WITH WIRES SMALLER THAN W3.1 OR SPACING GREATER THAN 8" BE PERMITTED. BAR REINFORCEMENT SHALL SHOW THE MINIMUM YIELD DESIGNATION GRADE MARK OF EITHER THE NUMBER 60 OR ONE (1) GRADE MARK LINE TO BE ACCEPTABLE AT THE HIGHER VALUE. MAXIMUM BAR SPACING SHALL NOT BE GREATER THAN THREE (3) TIMES THE WALL THICKNESS OR 12".

EQUIVALENT STEEL AREA TABLE

GRADE 40 REINFORCING BAR		EQUIVALENT GRADE 60 REINFORCING BAR		EQUIVALENT 65 KSI SMOOTH WELDED WIRE FABRIC		EQUIVALENT 70 KSI DEFORMED WELDED WIRE FABRIC	
Bar Size & Spacing	Steel Area (in ² /ft)	Bar Size & Spacing	Min Steel Area	Style Designation	Min Steel Area	Style Designation	Min Steel Area
#4 @ 12" CCEW	0.20	#3 @ 9 1/2" CCEW	.1333	3"x3"-W3.1xW3.1 or 4"x4"-W4.5xW4.5 or 6"x6"-W6.5xW6.5	.1230	3"x3"-D4.3xD4.3 or 4"x4"-D5.7xD5.7 or 6"x6"-D8.6xD8.6	0.1714
#4 @ 9" CCEW	0.20	#3 @ 13 1/2" CCEW or #3 @ 7" CCEW	.1778	3"x3"-W3.1xW3.1 or 4"x4"-W5.5xW5.5 or 6"x6"-W8.5xW8.5	.1641	3"x3"-D5.7xD5.7 or 4"x4"-D7.6xD7.6 or 6"x6"-D11.4xD11.4	0.2289
#6 @ 6" CCEW	0.20	#3 @ 9 1/2" CCEW or #6 @ 9" CCEW	.5867	4"x4"-W20xW20 or 6"x6"-W30xW30	.5415	3"x3"-D15.6xD15.6 or 4"x4"-D20.9xD20.9 or 6"x6"-D31.3xD31.3	0.6257
#7 @ 6" CCEW	0.20	#3 @ 6 1/2" CCEW or #7 @ 9" CCEW	.80	4"x4"-W26xW26	.7385	3"x3"-D31.3xD31.3 or 4"x4"-D41.7xD41.7	1.2514

NOTES FOR MANHOLES & INLETS

**CITY OF
JACKSONVILLE
STANDARD**

N.T.S.

PLATE D-107

DATE DRAWN 07/12/79

REVISED DATE 7-2-24

SLAB DESIGNS - SQUARE AND RECTANGULAR STRUCTURES
(ALL SLABS 8" THICK - REINFORCING PARALLEL TO SHORT WAY AND LONG WAY)

LONG-WAY		SHORT-WAY	
SLAB DEPTH	SCHEDULE	SLAB DEPTH	SCHEDULE
SIZE: 4'-0"xUNLIMITED			
≥ 0.5' < 19'	B	≥ 0.5' < 34'	B
19' < 29'	C	34'-40'	C
29'-40'	D		
SIZE: 5x5'			
≥ 0.5' < 3'	C	≥ 0.5' < 3'	C
3' < 19'	B	3' < 19'	B
19' < 28'	C	19' < 28'	C
28' < 38'	D	28' < 38'	D
38'-40'	F	38'-40'	F
SIZE: 5x6'			
≥ 0.5' < 3'	C	≥ 0.5' < 3'	C
3' < 16'	B	3' < 20'	B
16' < 24'	C	20' < 29'	C
24' < 34'	D	29'-40'	D
34'-40'	F		
SIZE: 5x7'			
≥ 0.5' < 3'	C	≥ 0.5' < 3'	C
3' < 14'	B	3' < 22'	B
14' < 21'	C	22' < 33'	C
21' < 39'	D	33'-40'	D
39'-40'	F		
SIZE: 5x8'			
≥ 0.5' < 3'	C	≥ 0.5' < 39'	B
3' < 8'	B	39'-40'	C
8' < 17'	C		
17' < 23'	D		
23'-40'	F		
SIZE: 5x9'			
≥ 0.5' < 3'	C	≥ 0.5' < 32'	B
3' < 8'	B	32'-40'	C
8' < 17'	C		
17' < 23'	D		
23'-40'	F		
SIZE: 6x6'			
≥ 0.5' < 3'	D	≥ 0.5' < 3'	D
3' < 4'	C	3' < 4'	C
4' < 14'	B	4' < 14'	B
14' < 21'	C	14' < 21'	C
21' < 28'	D	21' < 28'	D
28'-40'	F	28'-40'	F
SIZE: 6x7'			
≥ 0.5' < 3'	D	≥ 0.5' < 3'	D
3' < 4'	C	3' < 4'	C
4' < 12'	B	4' < 15'	B
12' < 19'	C	15' < 21'	C
19' < 26'	D	21' < 30'	D
26'-40'	F	30'-40'	F

LONG-WAY		SHORT-WAY	
SLAB DEPTH	SCHEDULE	SLAB DEPTH	SCHEDULE
SIZE: 6x8'			
≥ 0.5' < 3'	D	≥ 0.5' < 3'	D
3' < 4'	C	3' < 4'	C
4' < 7'	B	4' < 16'	B
7' < 16'	C	16' < 23'	C
16' < 23'	D	23' < 32'	D
23'-40'	F	32'-40'	F
SIZE: 6x9'			
≥ 0.5' < 3'	D	≥ 0.5' < 3'	D
3' < 15'	C	3' < 4'	C
15' < 21'	D	4' < 18'	B
21' < 27'	E	18' < 27'	C
27'-40'	G	27' < 37'	D
		37'-40'	E
SIZE: 7x7'			
≥ 0.5' < 3'	E	≥ 0.5' < 3'	E
3' < 4'	D	3' < 4'	D
4' < 16'	C	4' < 16'	C
16' < 22'	D	16' < 22'	D
22' < 28'	E	22' < 28'	E
28'-40'	G	28'-40'	G
SIZE: 7x8'			
≥ 0.5' < 3'	E	≥ 0.5' < 3'	E
3' < 4'	D	3' < 4'	D
4' < 15'	C	4' < 17'	C
15' < 21'	D	17' < 23'	D
21' < 27'	E	23' < 29'	E
27'-40'	G	29'-40'	G
SIZE: 7x9'			
≥ 0.5' < 3'	E	≥ 0.5' < 3'	E
3' < 4'	D	3' < 4'	D
4' < 12'	C	4' < 18'	C
12' < 18'	D	18' < 24'	D
18' < 24'	E	24' < 32'	E
24'-40'	G	32'-40'	G
SIZE: 8x8'			
≥ 0.5' < 3'	D	≥ 0.5' < 3'	D
3' < 4'	C	3' < 4'	C
4' < 9'	B	4' < 9'	B
9' < 17'	C	9' < 17'	C
17' < 31'	D	17' < 31'	D
31'-40'	G	31'-40'	G
SIZE: 8x9'			
≥ 0.5' < 3'	D	≥ 0.5' < 3'	E
3' < 4'	C	3' < 4'	D
4' < 16'	B	4' < 18'	C
16' < 22'	C	18' < 25'	D
22' < 29'	D	25' < 32'	F
29'-40'	F	32'-40'	G
SIZE: 9x9'			
≥ 0.5' < 3'	F	≥ 0.5' < 3'	F
3' < 14'	C	3' < 14'	C
14' < 20'	D	14' < 20'	D
20' < 26'	E	20' < 26'	E
26'-40'	G	26'-40'	G

SLAB DESIGN SQUARE
AND RECTANGULAR
STRUCTURES

**CITY OF
JACKSONVILLE
STANDARD**

N.T.S.

PLATE D-108

DATE DRAWN 1-31-79

REVISED DATE 7-2-24

WALL DESIGNS - RECTANGULAR STRUCTURES

HORIZONTAL REINFORCING		VERTICAL REINFORCING	
WALL DEPTH	SCHEDULE	WALL DEPTH	SCHEDULE
SIZE: 3'-0"			
≥ 1.17'-40'	A	≥ 1.17'-40'	B
SIZE: 4'-0"			
≥ 1.17'-40'	A	≥ 1.17'-40'	B
SIZE: 5'-0"			
≥ 1.17'-40'	A	≥ 1.17' < 33'	B
		33'-40'	C
SIZE: 6'-0"			
≥ 1.17'-40'	A	≥ 1.17' < 22'	B
		22'-40'	C
SIZE: 7'-0"			
≥ 1.17'-40'	A	≥ 1.17' < 15'	B
		15' < 25'	C
		25'-40'	D
SIZE: 8'-0"			
≥ 1.17'-40'	A	≥ 1.17' < 11'	B
		11' < 19'	C
		19' < 29'	D
		29'-40'	F
SIZE: 9'-0"			
≥ 1.17'-40'	A	≥ 1.17' < 15'	C
		15' < 22'	D
		22'-40'	F

NOTES:

1. SLAB REINFORCEMENT IS APPROPRIATE FOR TOP, INTERMEDIATE, AND BOTTOM SLABS.
2. SLAB DEPTH IS MEASURED FROM FINISHED GRADE TO TOP OF SLAB.
3. WALL DESIGN DEPTH IS MEASURED TO THE TOP OF THE BOTTOM SLAB FOR BOXES AND TO THE TOP OF THE INTERMEDIATE SLAB FOR RISERS.
4. WALL HEIGHT IS THE DISTANCE BETWEEN TOP OF LOWER SLAB TO BOTTOM OF UPPER SLAB.

REINFORCING SCHEDULE

SCHEDULE	GRADE 60 STEEL OR 65 KSI (WELDED WIRE FABRIC) 2 in /ft
A	0.20
B	0.24
C	0.37
D	0.53
E	0.73
F	1.06
G	1.45

WALL DESIGNS
RECTANGULAR
STRUCTURES

**CITY OF
JACKSONVILLE
STANDARD**

N.T.S.

PLATE D-109

DATE DRAWN 2-5-79

REVISED DATE 7-2-24

SLAB DESIGNS - ROUND STRUCTURES

SLAB THICKNESS	SLAB DEPTH	(2 WAYS) REINFORCING SCHEDULE
SIZE: 4'-0"		
≥ 0.5' - 40'	8"	C
SIZE: 5'-0"		
≥ 0.5' < 30'	8"	C
30' - 40'	8"	D
SIZE: 6'-0"		
≥ 0.5' < 8'	8"	B
8' < 18'	8"	C
18' < 30'	8"	D
30' < 37'	8"	E
37' - 40'	8"	G
SIZE: 8'-0"		
≥ 0.5' < 9'	10"	C
9' < 15'	10"	D
15' < 23'	10"	E
23' < 33'	12"	E
33' - 40'	12"	G
SIZE: 10'-0"		
≥ 0.5' < 6'	10"	C
6' < 11'	10"	D
11' < 17'	10"	E
17' < 23'	12"	E
23' - 40'	12"	G
SIZE: 12'-0"		
≥ 0.5' < 6'	12"	C
6' < 11'	12"	D
11' < 16'	12"	E
16' < 20'	14"	E
20' - 40'	14"	G

NOTES:

1. SLAB REINFORCEMENT IS APPROPRIATE FOR TOP, INTERMEDIATE, AND BOTTOM SLABS.
2. SLAB DEPTH IS MEASURED FROM FINISHED GRADE TO TOP OF SLAB.
3. WALL DESIGN DEPTH IS MEASURED TO THE TOP OF THE BOTTOM SLAB FOR BOXES AND TO THE TOP OF THE INTERMEDIATE SLAB FOR RISERS.
4. WALL HEIGHT IS THE DISTANCE BETWEEN TOP OF LOWER SLAB TO BOTTOM OF UPPER SLAB.

REINFORCING SCHEDULE

SCHEDULE	GRADE 60 STEEL OR 65 KSI (WELDED WIRE FABRIC) 2 in /ft
A	0.20
B	0.24
C	0.37
D	0.53
E	0.73
F	1.06
G	1.45

SLAB DESIGN ROUND
STRUCTURES

**CITY OF
JACKSONVILLE
STANDARD**

N.T.S.

PLATE D-110

DATE DRAWN 1-31-79

REVISED DATE 7-2-24

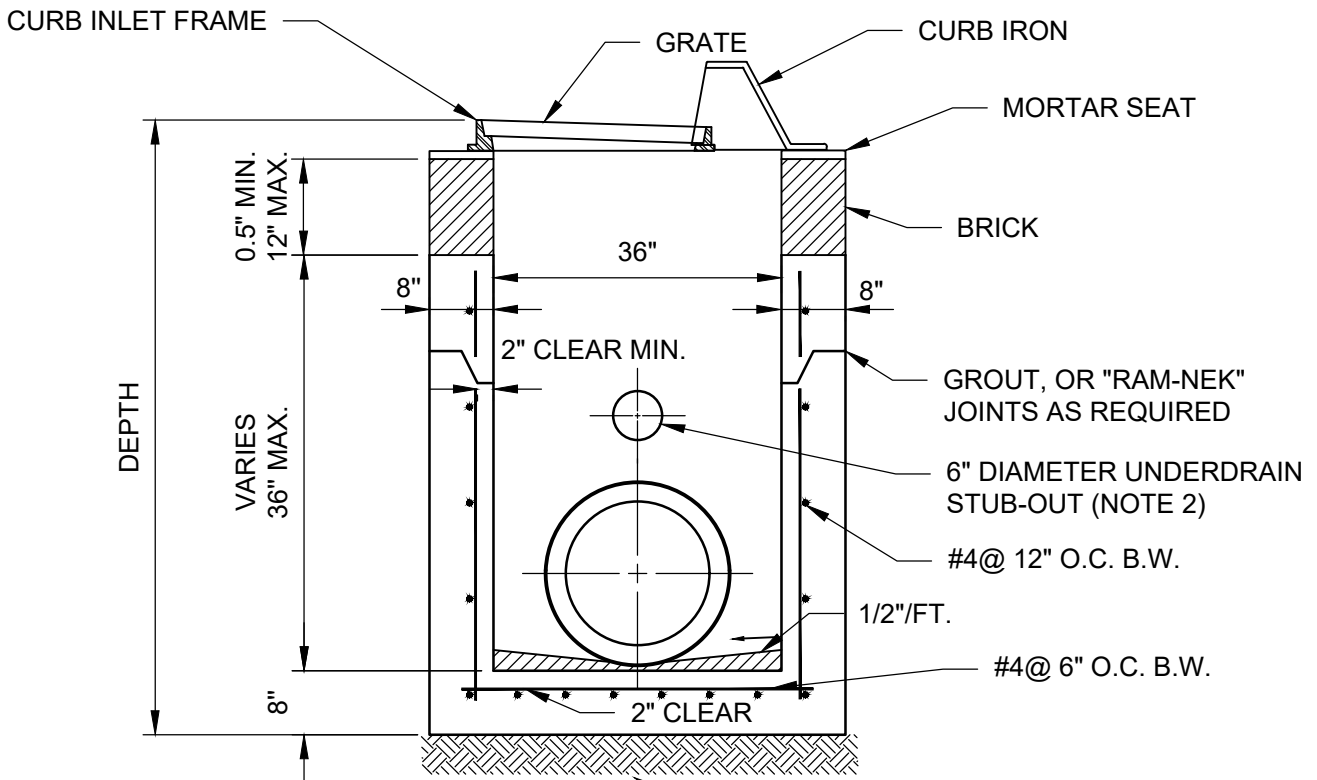
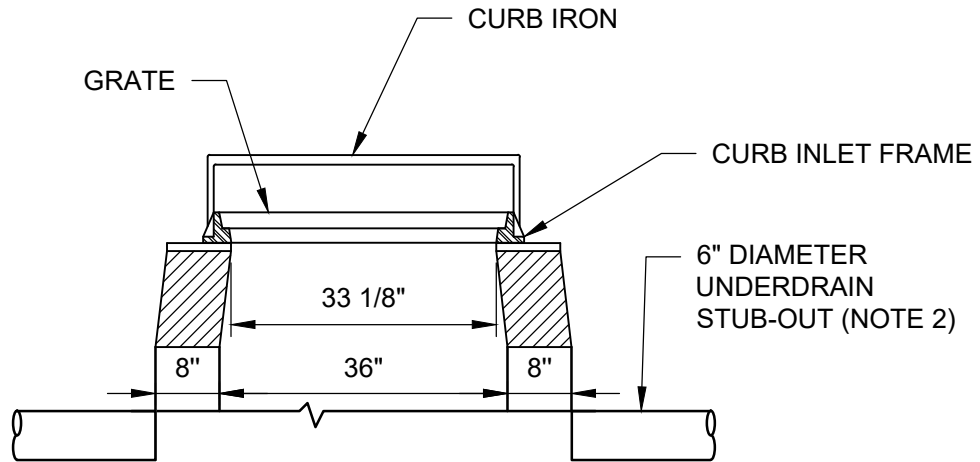

PIPE MUST NOT BE IN CONSTRUCTION JOINT

PIPES SHALL BE FLUSH WITH INSIDE WALL

BEARING CAPACITY MINIMUM 3000 PSF

NOTES:

1. CONSTRUCT PRECAST STRUCTURES WITH REINFORCED CONCRETE ONLY. DESIGN STRENGTH 4000 PSI.
2. NEW STORM INLETS TO INCLUDE A 10-FT UNDERDRAIN STUB-OUT ON EACH SIDE OF THE INLET. CONNECT UNDERDRAIN PIPES USING A 6-INCH DIAMETER SDR 35 INLET COUPLER CAST INTO THE INLET WALL. UNDERDRAIN INVERT SHALL BE LOCATED AT A MINIMUM DEPTH OF 30-IN AND ADJUSTED FOR FIELD CONDITIONS.
3. STUB-OUT ENDS REQUIRE A CAP OR FILTER-FABRIC WRAP.

CURB INLET	CITY OF JACKSONVILLE STANDARD	N.T.S.	PLATE D-201
		DATE DRAWN	2-10-79
		REVISED DATE	01-24-25

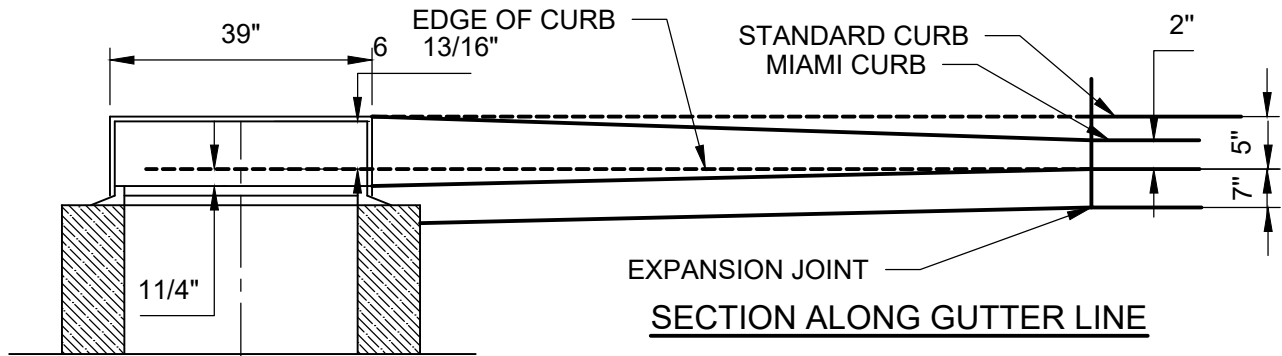

SYMETRICAL ABOUT CL

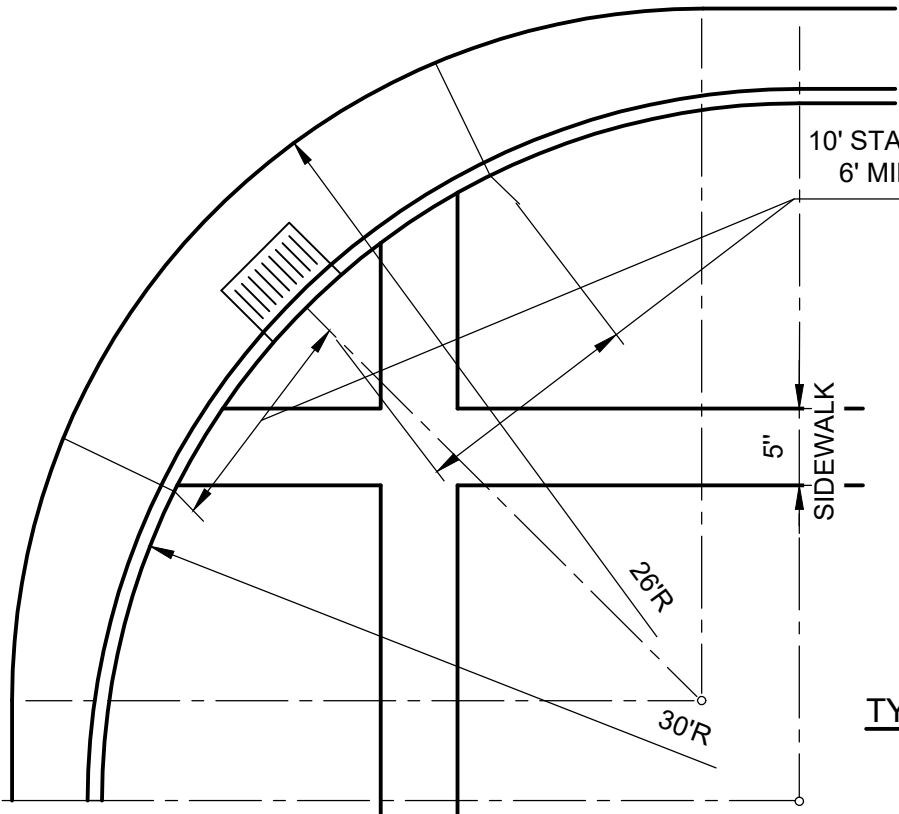
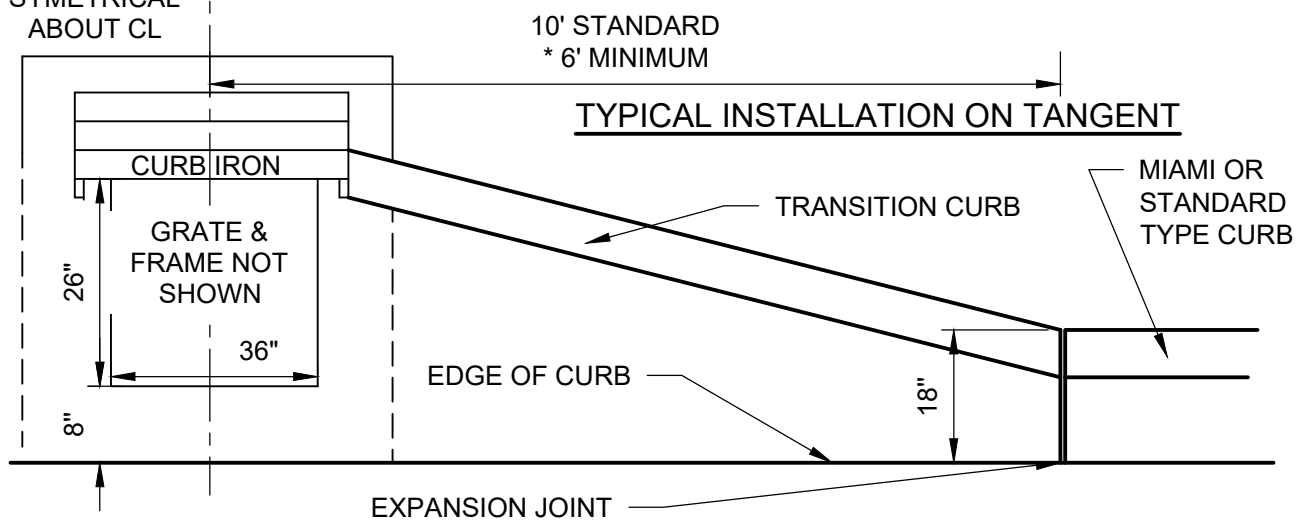

* CURB TRANSITION LESS THAN 10' TO BE USED WHERE LOT FRONTAGE IS 60' OR LESS, IN CASE OF HANDICAP RAMP CONFLICTS, OR AS APP'D. BY THE CITY ENGINEER.

TYPICAL INSTALLATION ON CURB RETURN

STANDARD CURB INLET INSTALLATION

CITY OF JACKSONVILLE STANDARD

N.T.S.

PLATE D-202

DATE DRAWN 2-10-79

REVISED DATE 01/14/03

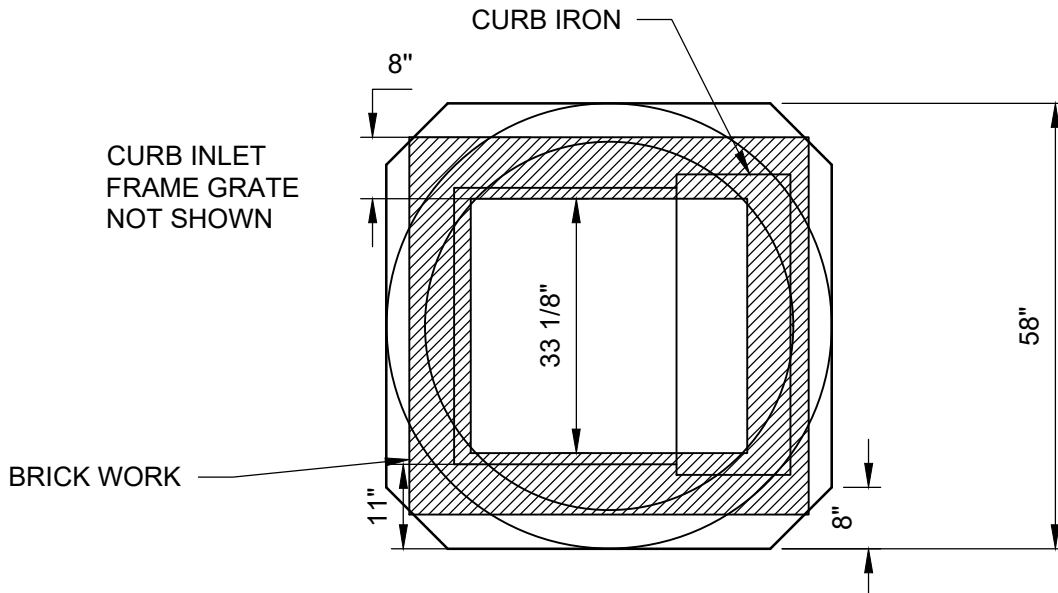

NOTE: CONC. DESIGN STRENGTH 4,000 PSI

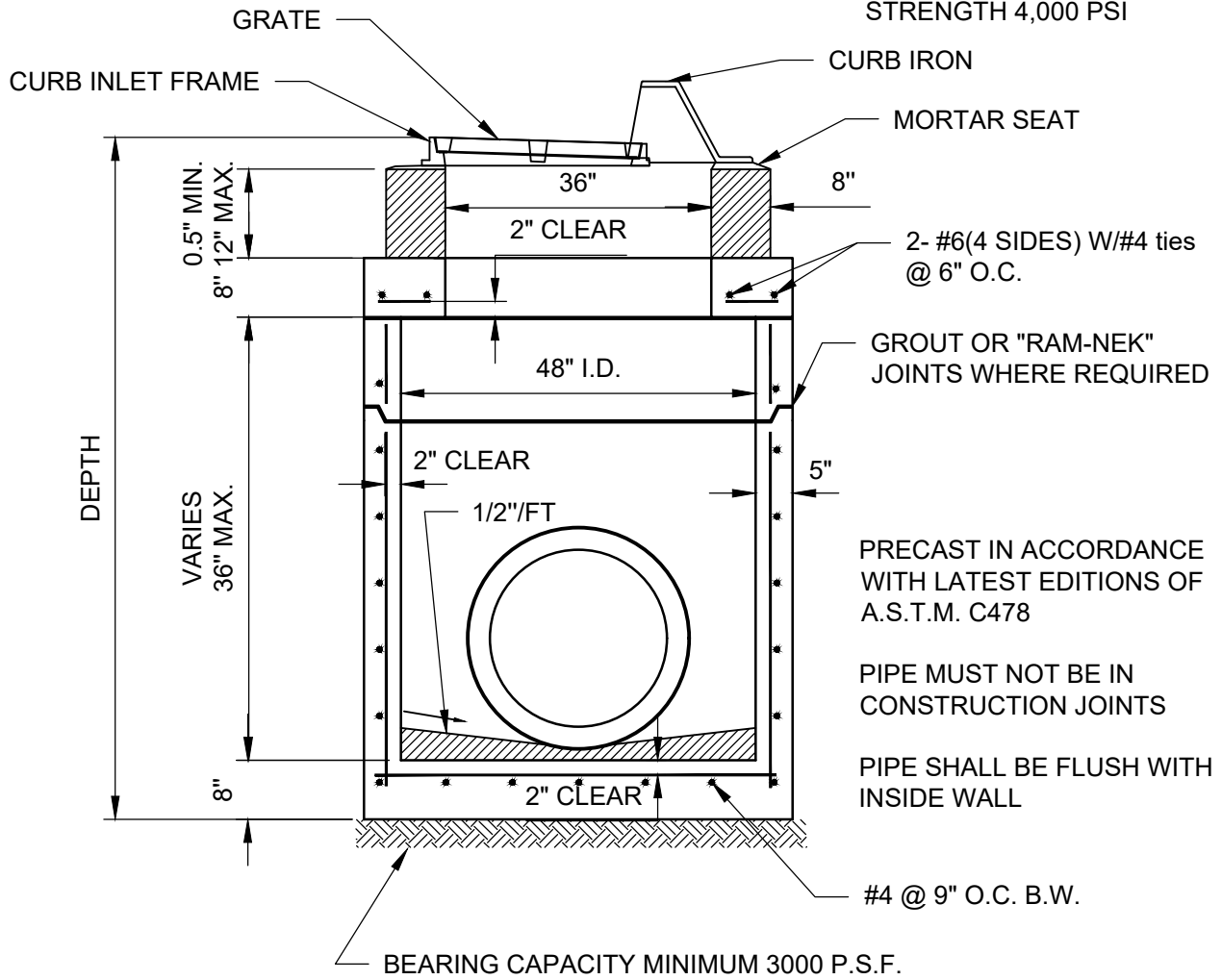

48" I.D. CURB INLET

CITY OF JACKSONVILLE STANDARD

N.T.S.

PLATE D-203

DATE DRAWN 4-21-79

REVISED DATE 5-12-94

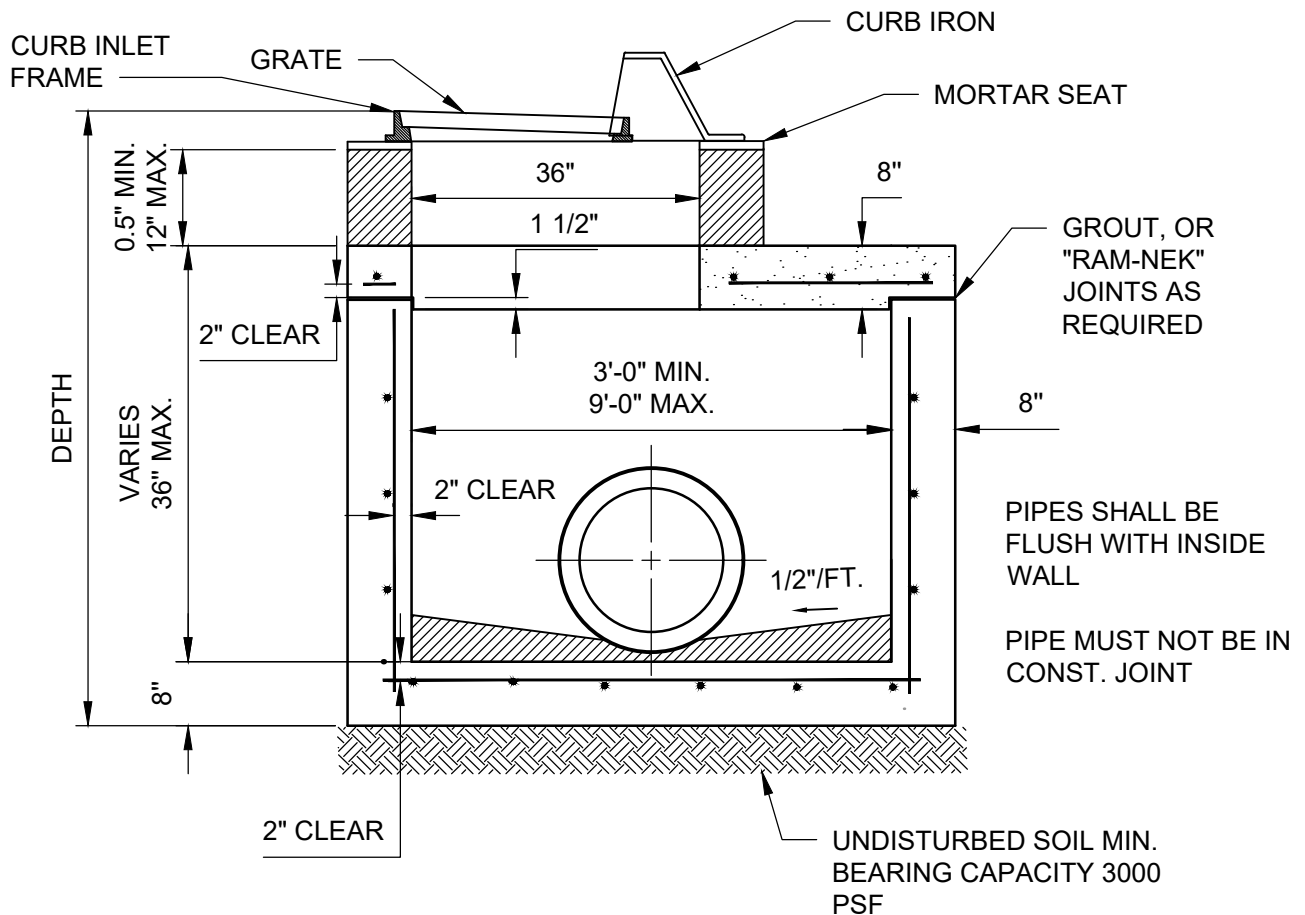
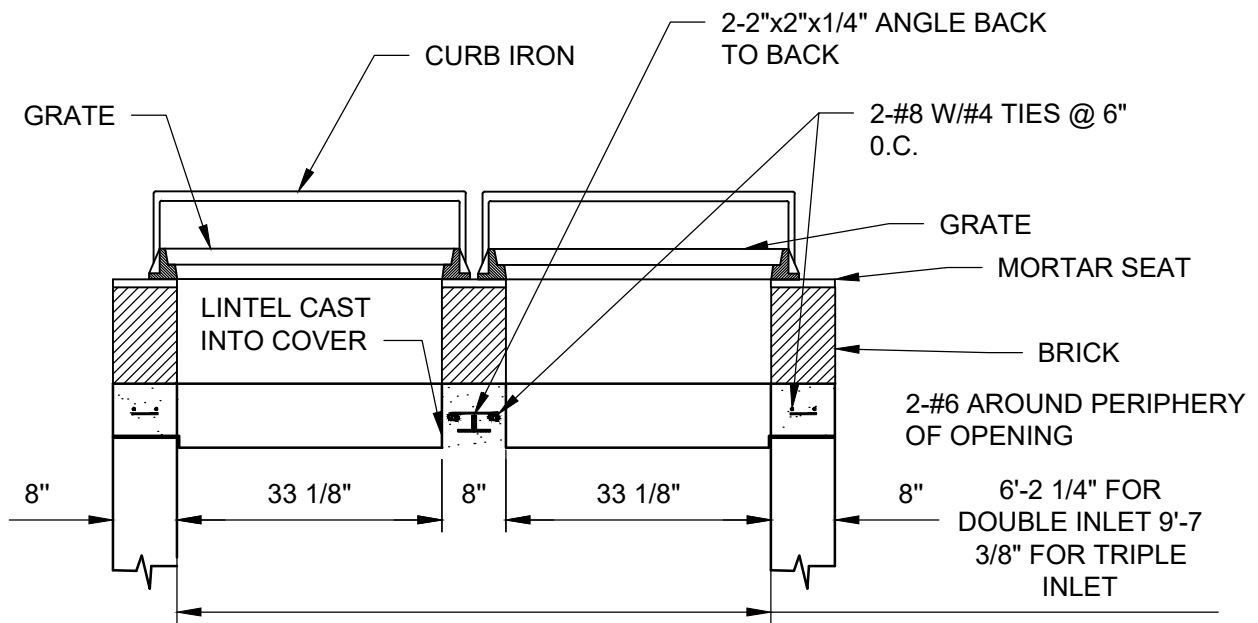

NOTE: FOR ADDITIONAL STRUCTURAL DETAIL REFER TO PLATE D-107, D-108, & D-109

DOUBLE AND TRIPLE CURB INLET

CITY OF JACKSONVILLE STANDARD

N.T.S.

PLATE D-204

DATE DRAWN 4-26-79

REVISED DATE 5-12-94

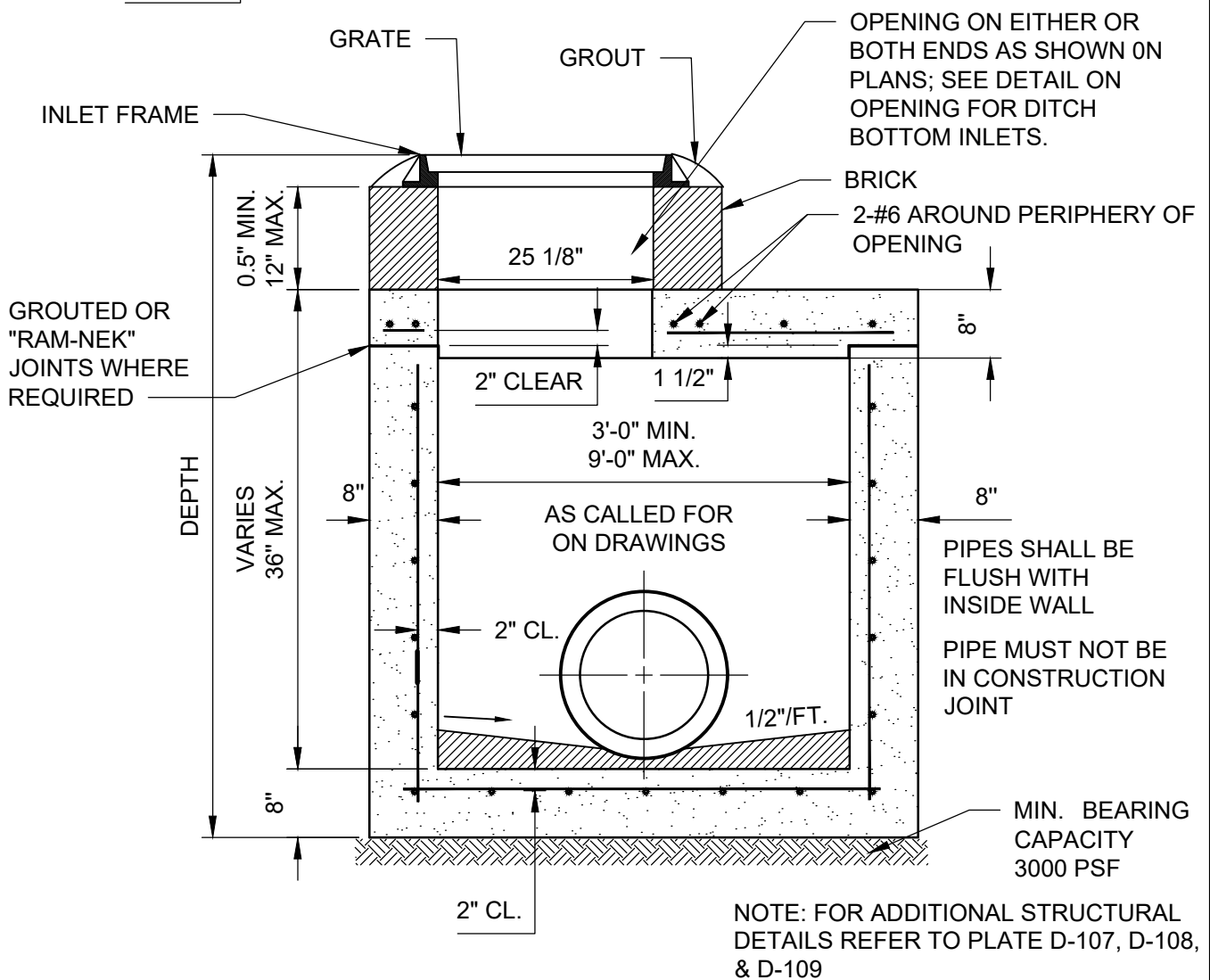
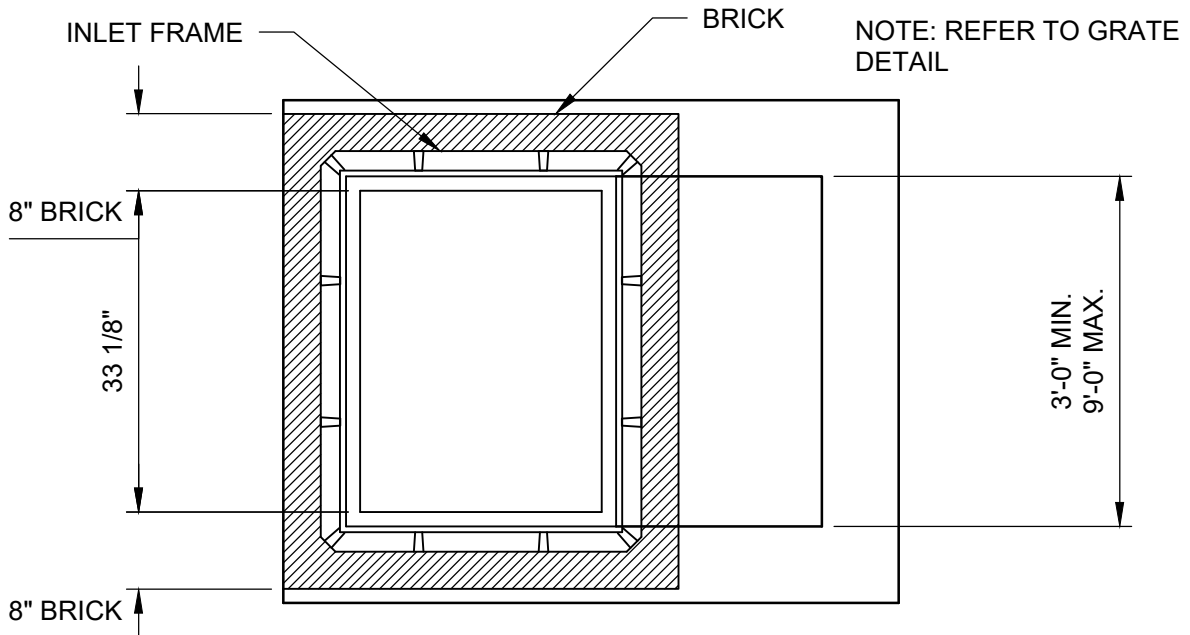

TYPE "B" INLET

CITY OF
JACKSONVILLE
STANDARD

N.T.S.

PLATE D-205

DATE DRAWN 5-15-79

REVISED DATE 5-12-94

THROAT OPENING ON EITHER OR BOTH SIDES AS SHOWN ON PLANS; SEE DETAILS ON OPENING FOR DITCH BOTTOM INLETS.

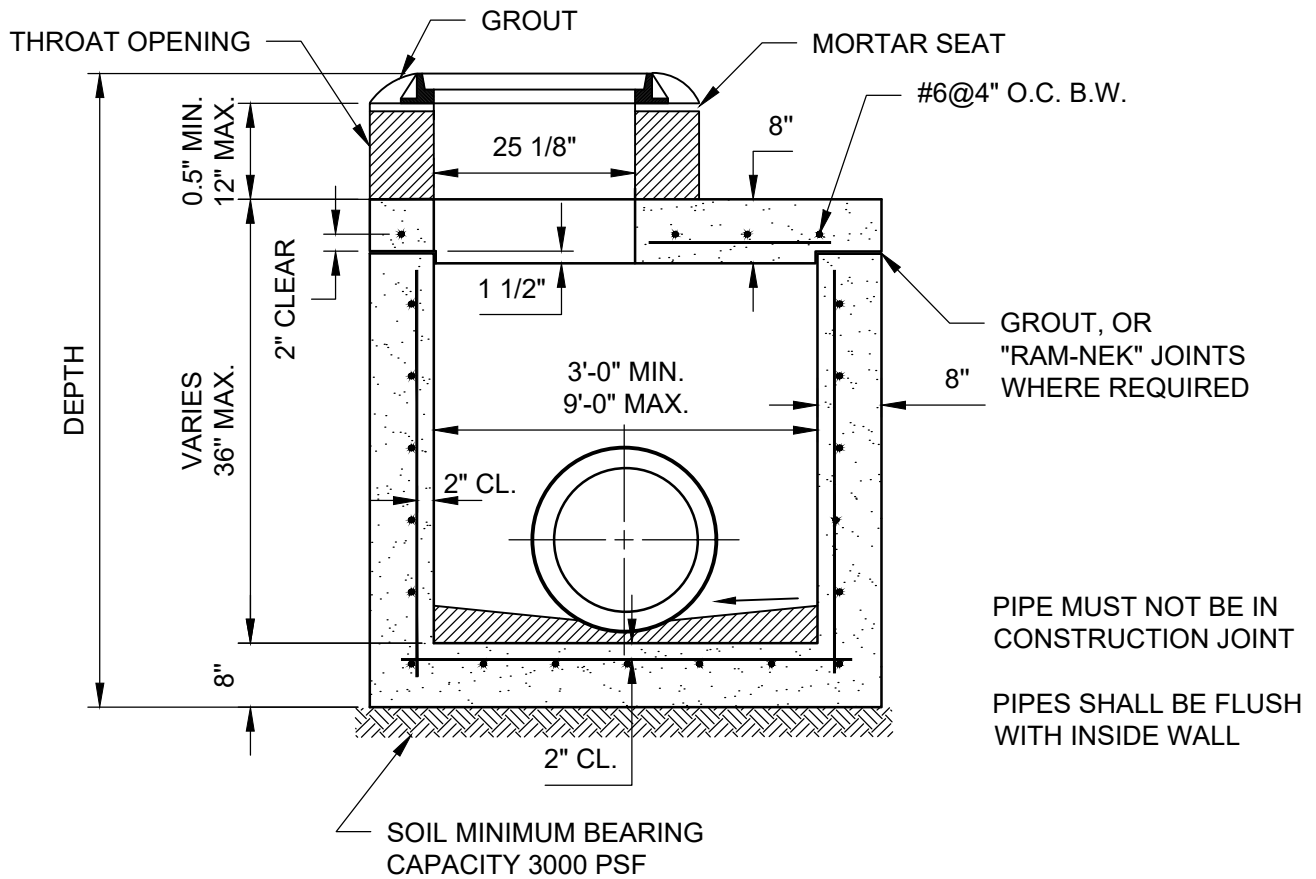
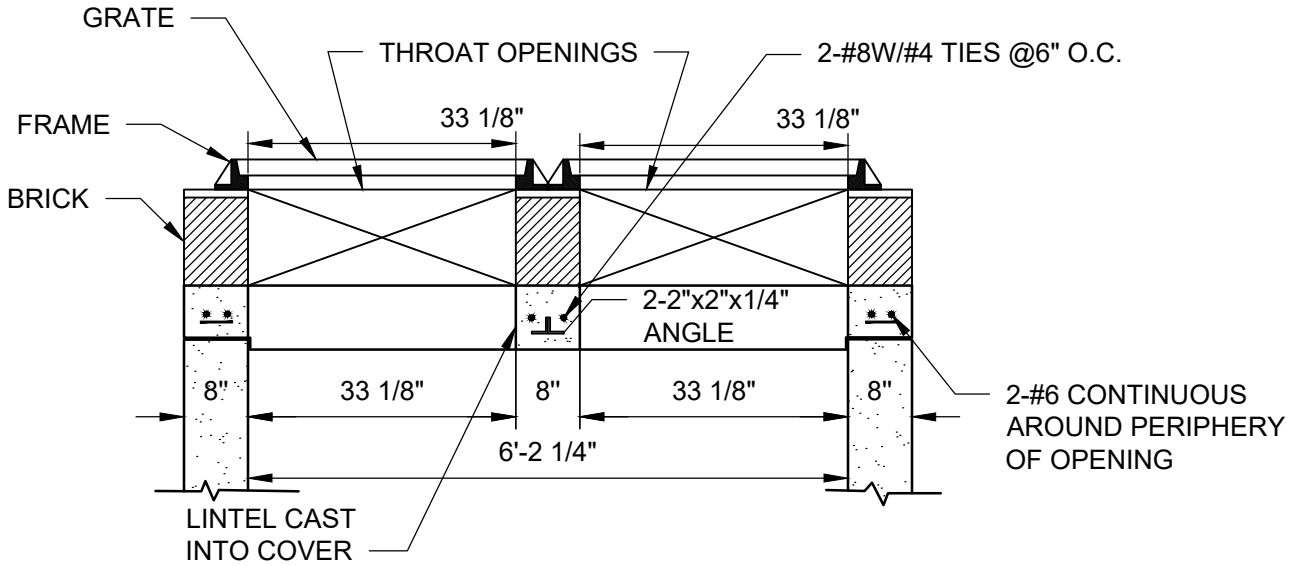

NOTE: FOR ADDITIONAL STRUCTURAL DETAIL REFER TO PLATE D-107, D-108, & D-109

DOUBLE TYPE "B" INLET

CITY OF
JACKSONVILLE
STANDARD

N.T.S.

PLATE D-206

DATE DRAWN 5-16-79

REVISED DATE 5-12-94

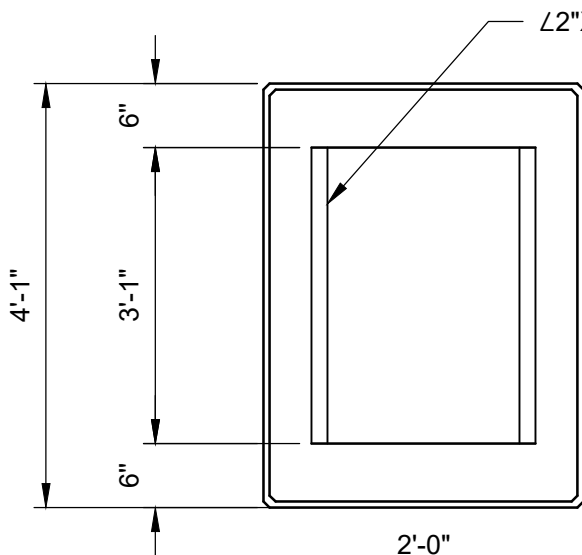

NOTE: REFER TO GRATE
DETAIL

SLOT OPENINGS SHALL NOT
BE IN WALLS WITH GRATE
SEAT

NOTE: CONC. DESIGN
STRENGTH 4000 P.S.I.

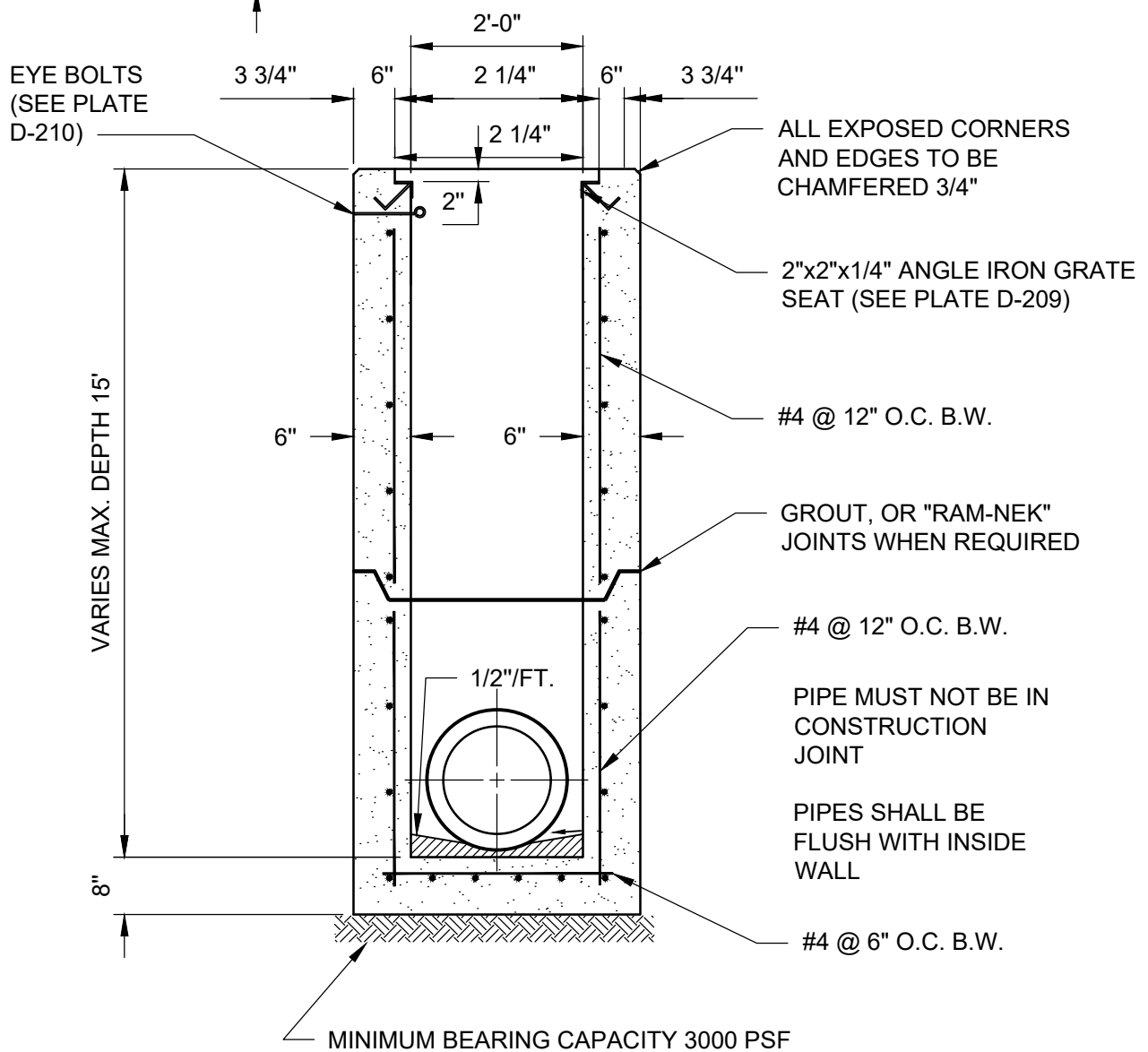

EYE BOLTS
(SEE PLATE
D-210)

ALL EXPOSED CORNERS
AND EDGES TO BE
CHAMFERED 3/4"

2"x2"x1/4" ANGLE IRON GRATE
SEAT (SEE PLATE D-209)

#4 @ 12" O.C. B.W.

GROUT, OR "RAM-NEK"
JOINTS WHEN REQUIRED

#4 @ 12" O.C. B.W.

PIPE MUST NOT BE IN
CONSTRUCTION
JOINT

PIPES SHALL BE
FLUSH WITH INSIDE
WALL

#4 @ 6" O.C. B.W.

MINIMUM BEARING CAPACITY 3000 PSF

TYPE "C" INLET

CITY OF
JACKSONVILLE
STANDARD

N.T.S.

PLATE D-207

DATE DRAWN 5-19-79

REVISED DATE 5-12-94

SEE PLATE D-307 FOR GRATE DETAIL

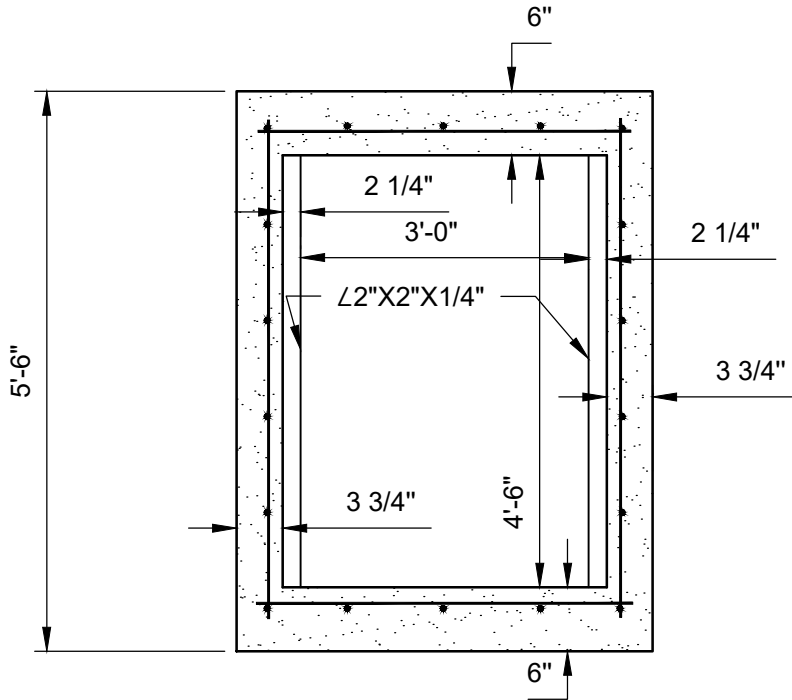

SLOT OPENINGS SHALL NOT BE IN WALLS WITH GRATE SEAT

NOTE: CONC. DESIGN STRENGTH 4,000 P.S.I.

PLAN

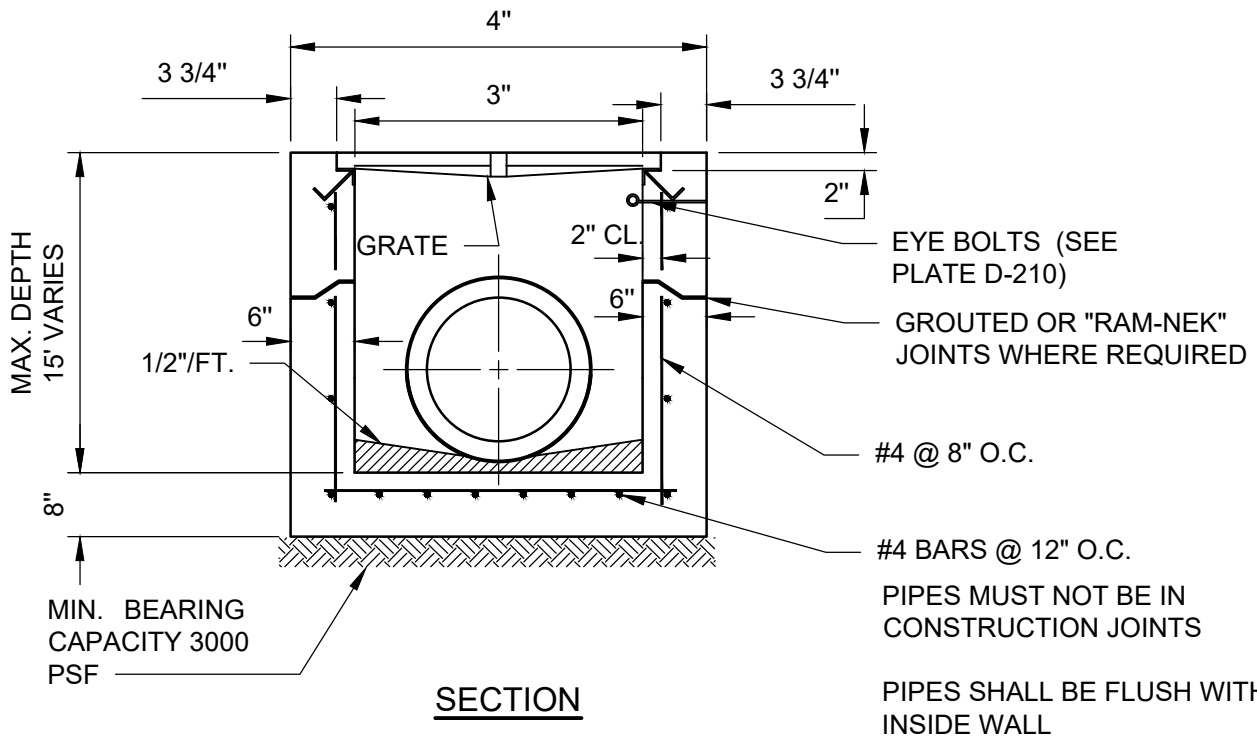

EYE BOLTS (SEE PLATE D-210)

GROUTED OR "RAM-NEK" JOINTS WHERE REQUIRED

#4 @ 8" O.C.

#4 BARS @ 12" O.C.

PIPES MUST NOT BE IN CONSTRUCTION JOINTS

PIPES SHALL BE FLUSH WITH INSIDE WALL

SECTION

TYPE "E" INLET

CITY OF JACKSONVILLE STANDARD

N.T.S.

PLATE D-208

DATE DRAWN 5-23-79

REVISED DATE 5-12-94

NOTE:

ALL TYPE C" & E" INLETS WITH SLOTS DEEPER THAN 6" SHALL BE CONSTRUCTED WITH A HORIZONTAL BAR(S) MAXIMUM SPACING 6". 1" DIAMETER GALV. PIPE EMBEDDED 2" IN PRE-CAST OR OTHER APPROVED METHOD.

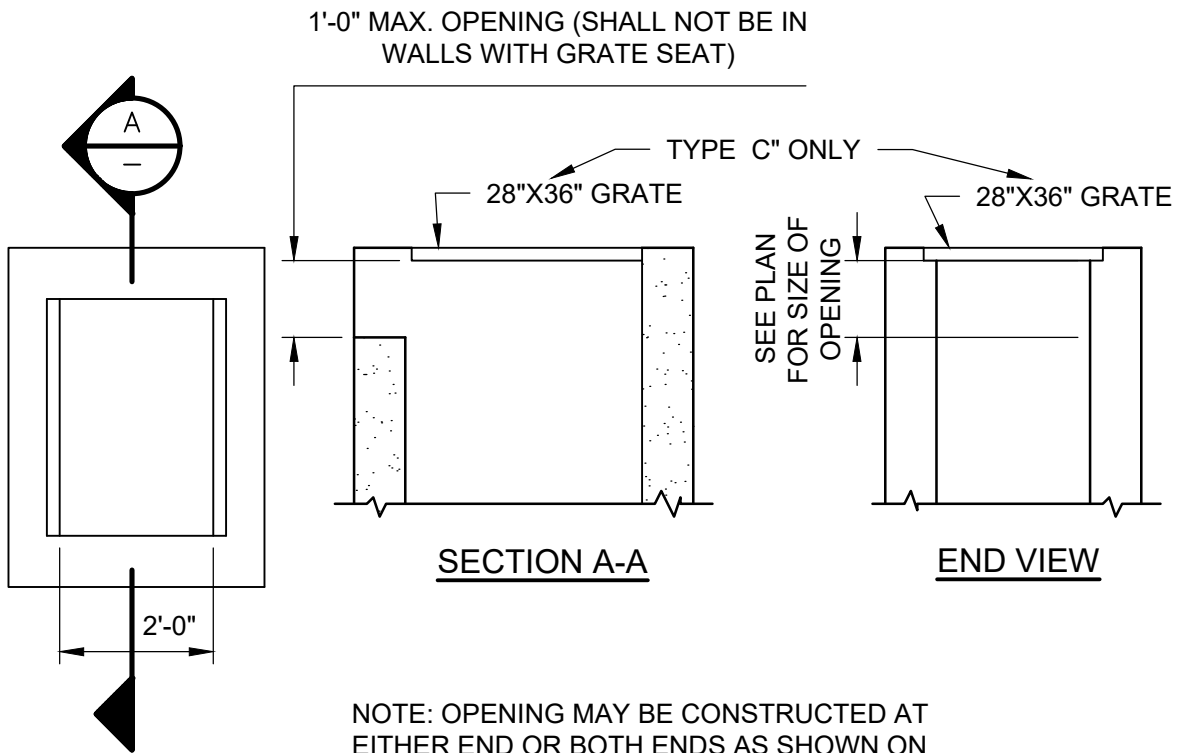

DETAILS OF OPENINGS IN DITCH BOTTOM INLETS

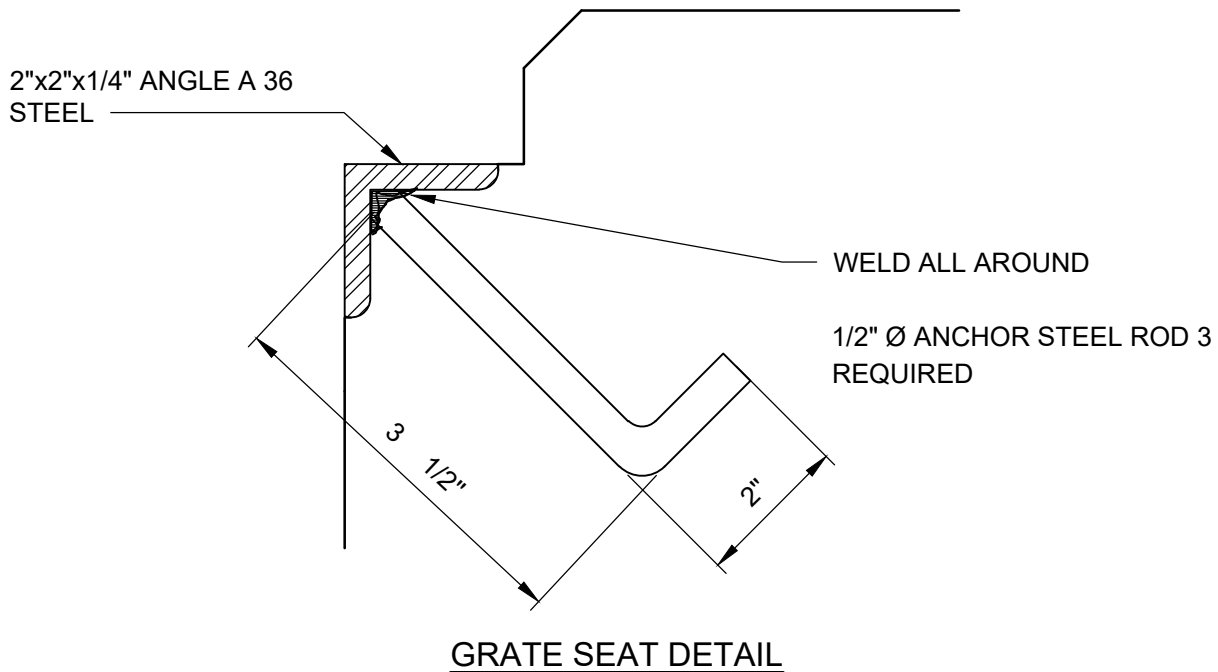

DETAIL FOR TYPE "C & E" INLET

CITY OF JACKSONVILLE STANDARD

N.T.S.

PLATE D-209

DATE DRAWN 5-24-79

REVISED DATE 5-12-94

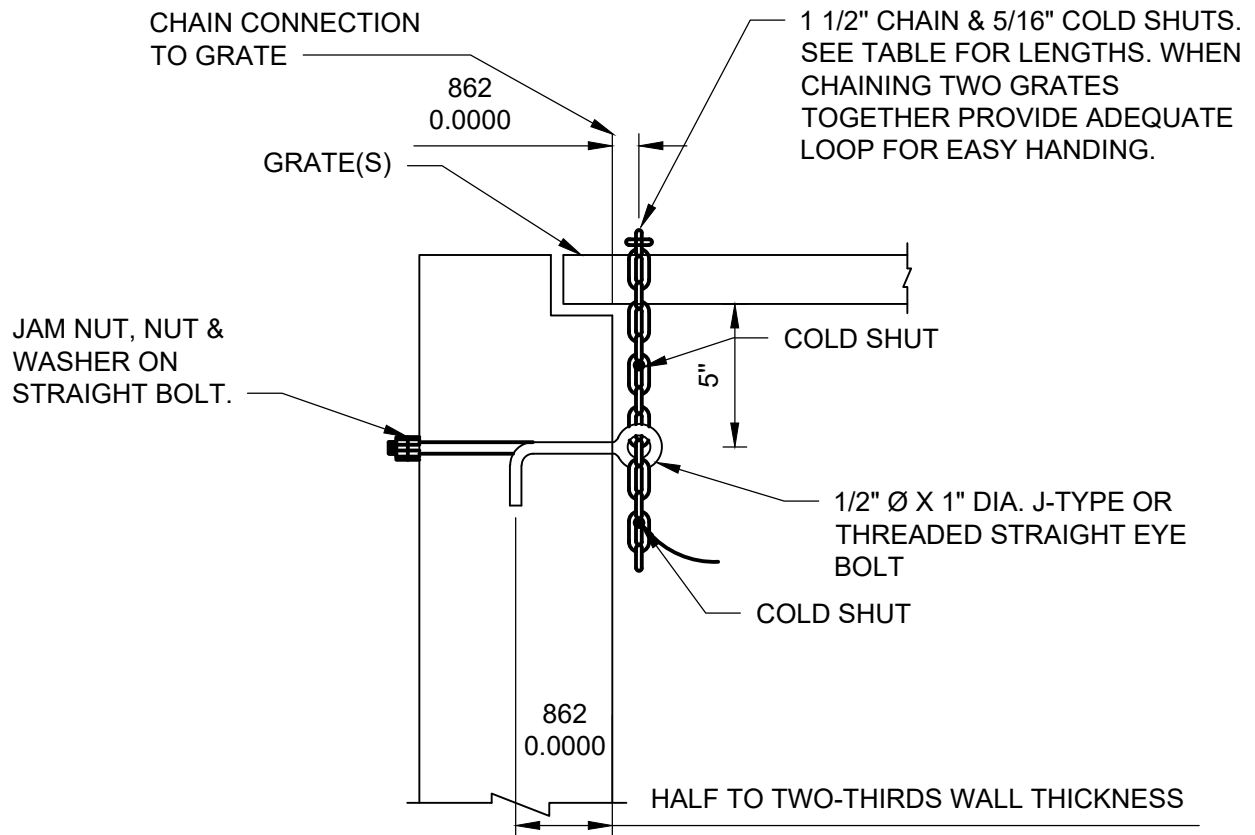

COST OF GALVANIZED EYE BOLT AND CHAIN TO BE INCLUDED IN THE CONTRACT UNIT PRICE FOR INLET.

EYE BOLT AND CHAIN REQUIREMENTS

PLATE NUMBER	INLET TYPE	EYE BOLT	LENGTH OF CHAIN	HANDLING AND REMARKS
207	C	1	2'-6"	SLIDE AND SPIN
208	E	2	2 @ 2'-6"	SLIDE AND SPIN

EYE BOLT AND CHAIN FOR LOCKING GRATES TO INLET

CITY OF
JACKSONVILLE
STANDARD

N.T.S.

PLATE D-210

DATE DRAWN 7-15-79

REVISED DATE 5-12-94

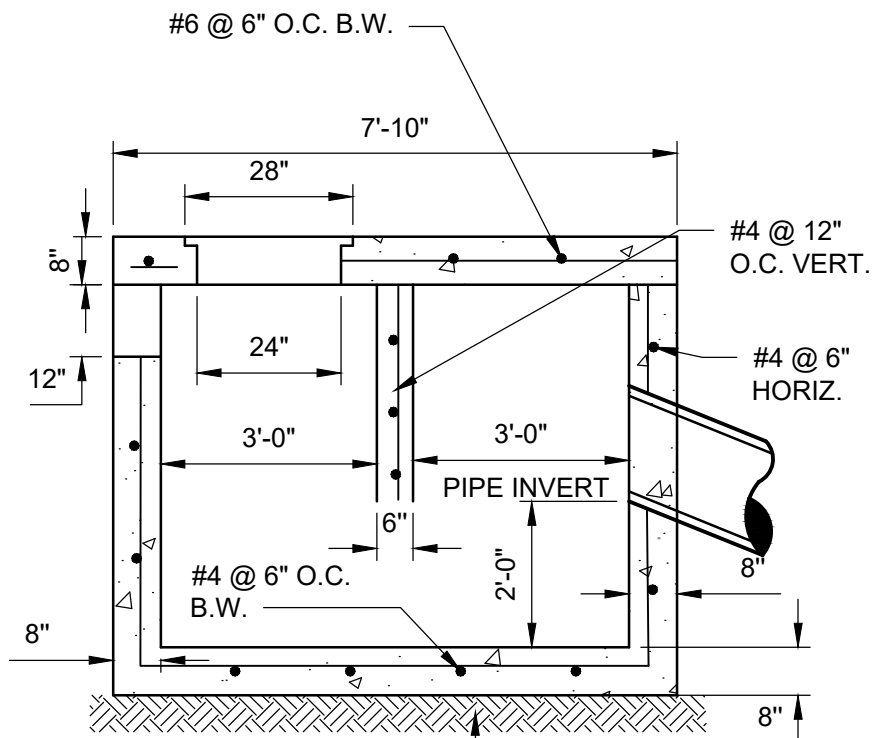
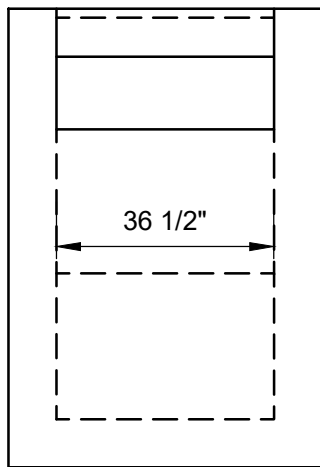
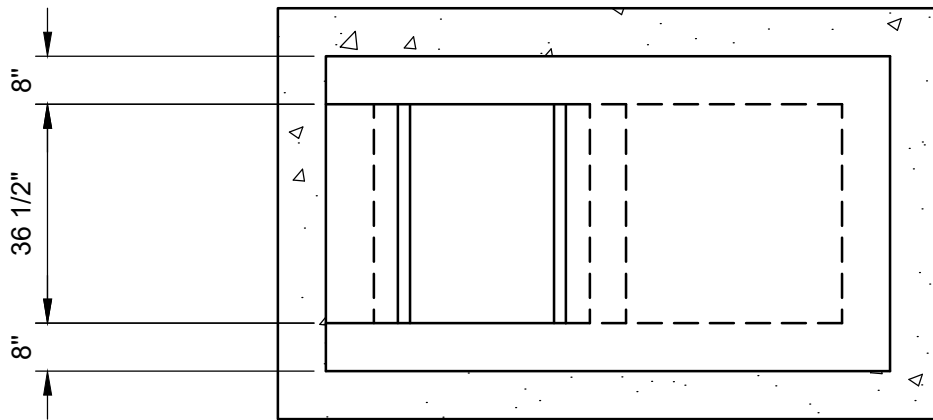

NOTE: CONC. DESIGN STRENGTH 4,000 P.S.I.

MIN. BEARING
DESIGN CAPACITY
3000 PSF

SAND TRAP BASIN

CITY OF
JACKSONVILLE
STANDARD

N.T.S.

PLATE D-211

DATE DRAWN 05-09-79

REVISED DATE 5-12-94

GENERAL NOTE: MORTAR USED TO SEAL THE PIPE INTO THE WALLS OF PRECAST UNITS WILL BE OF SUCH A MIX THAT SHRINKAGE WILL NOT CAUSE LEAKAGE INTO OR OUT OF THE UNITS. MAXIMUM OPENING FOR PIPE SHALL BE THE O.D. OF THE PIPE REQUIRED PLUS 6".

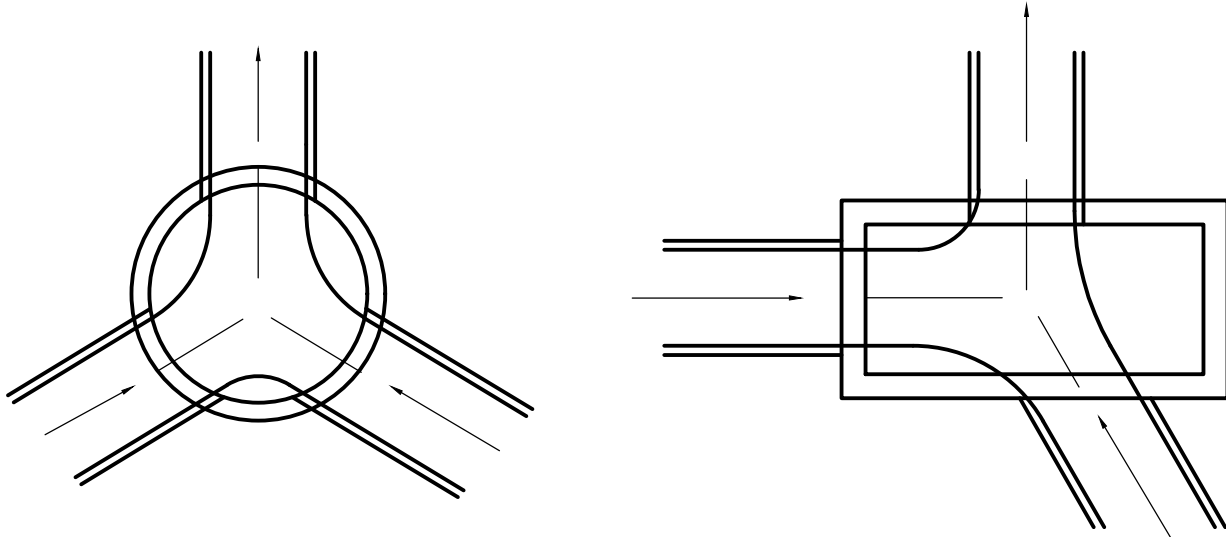

DETAIL OF CHANNELIZATION

NOTE: CHANNELIZATION REQUIRED AT ALL DRAINAGE STRUCTURES

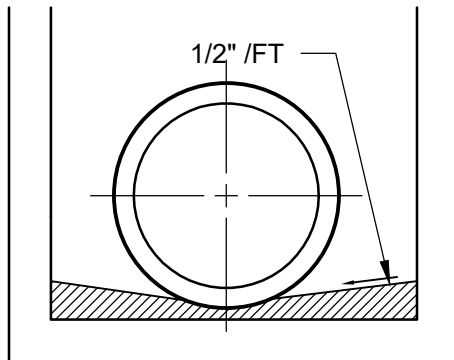

SMOOTH FLOW CHANNELS COMPOSED OF CONCRETE OR BRICK AND MORTAR SHALL BE CONSTRUCTED ON THE BOTTOMS OF ALL STRUCTURES TO A DEPTH EQUAL TO HALF THE DIAMETER OF THE LARGEST PIPE.

INVERT DETAIL	CITY OF JACKSONVILLE STANDARD	N.T.S.	PLATE D-212
		DATE DRAWN	08-05-79
		REVISED DATE	5-12-94

RAISED LETTERS, 1 3/4" HIGH
FLUSH WITH TOP OF COVER

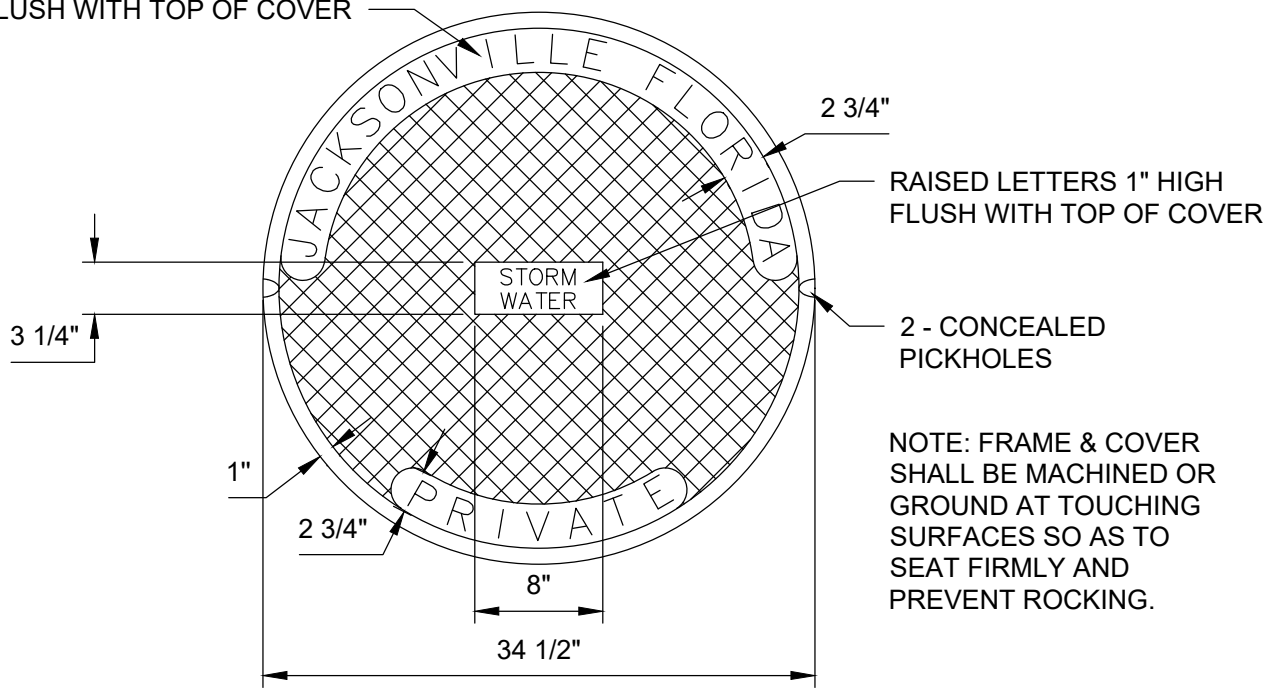

NOTE: FRAME & COVER
SHALL BE MACHINED OR
GROUND AT TOUCHING
SURFACES SO AS TO
SEAT FIRMLY AND
PREVENT ROCKING.

COVER
(265 LBS. ± 5 LBS.)

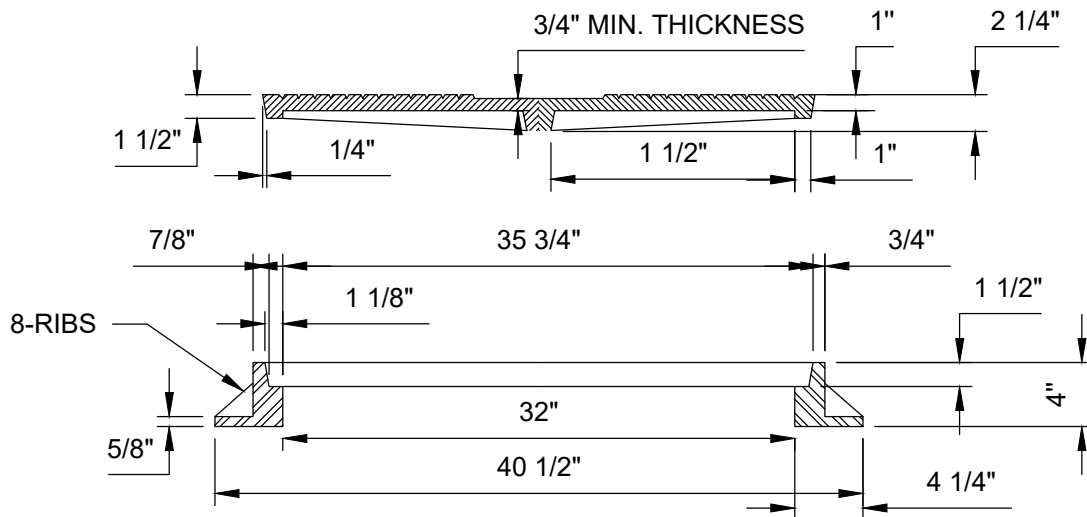

FRAME
(215 LBS. APPROX.)

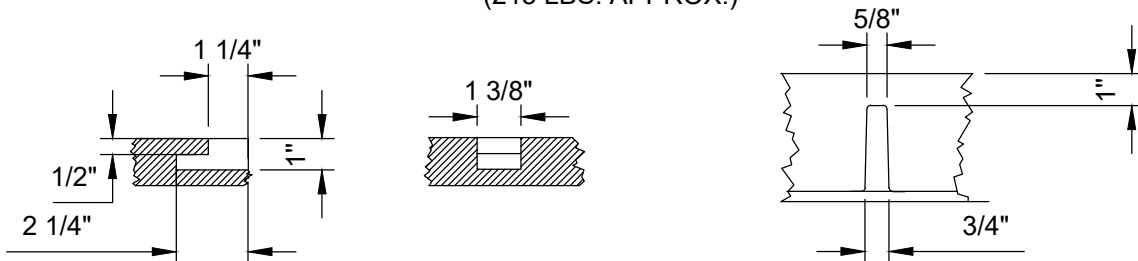

PICKHOLE DETAILS

RIB DETAIL

STORM SEWER MANHOLE
COVER AND FRAME

CITY OF
JACKSONVILLE
STANDARD

N.T.S.

PLATE D-301

DATE DRAWN 4-26-89

REVISED DATE 5-12-94

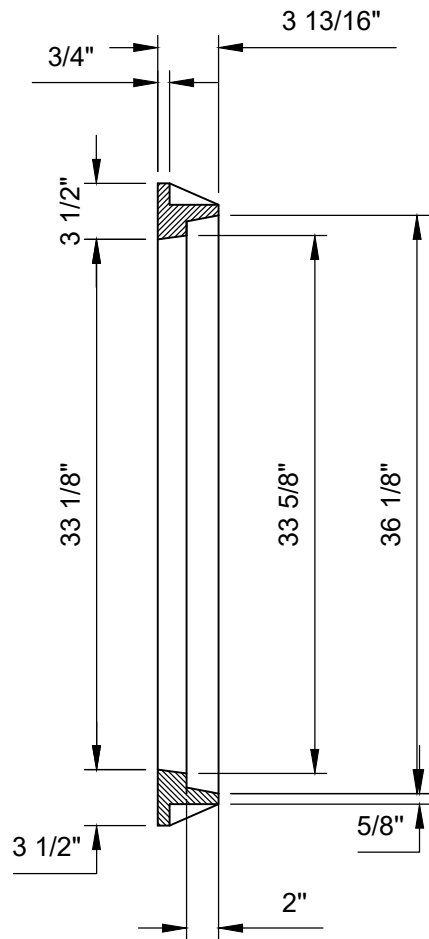

SECTION

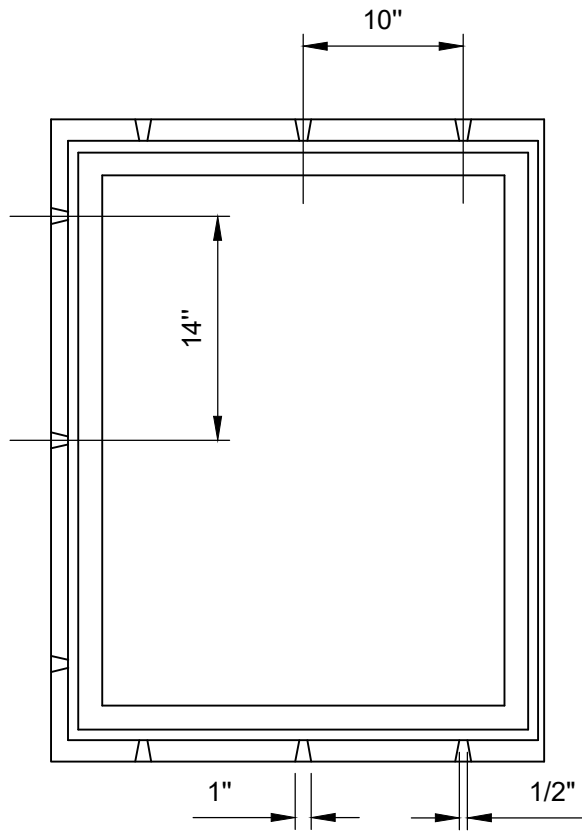

PLAN

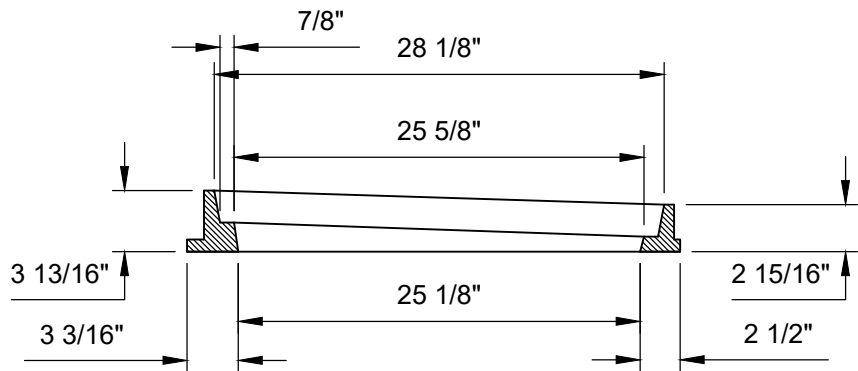

SECTION

APPROX. 180 LBS.

STORM SEWER CURB
INLET FRAME

CITY OF
JACKSONVILLE
STANDARD

N.T.S.

PLATE D-302

DATE DRAWN 4-24-89

REVISED DATE 5-12-94

APPROXIMATELY 230 LBS.

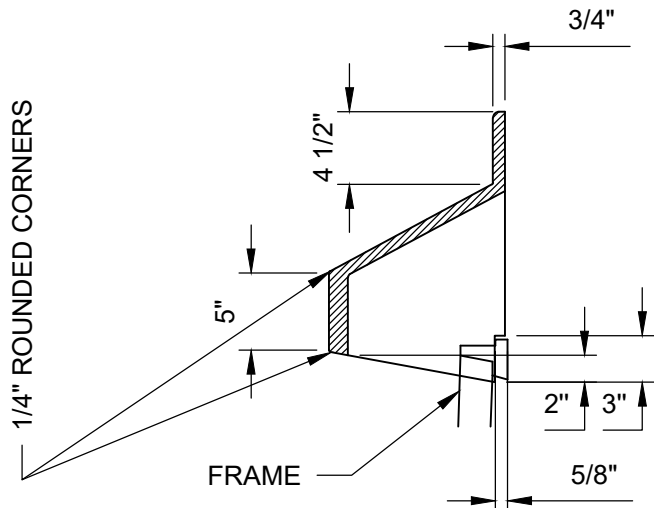

SECTION A-A

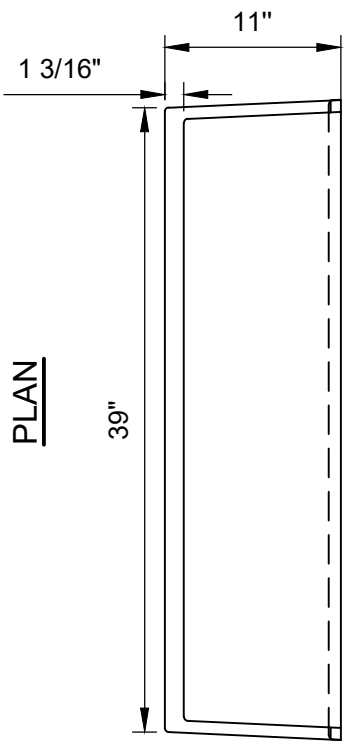
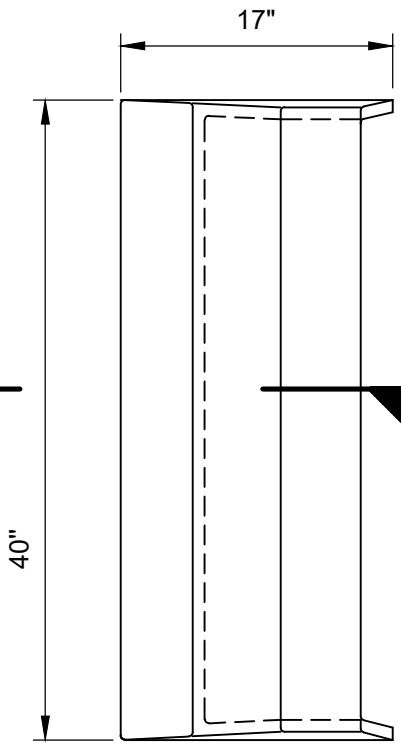
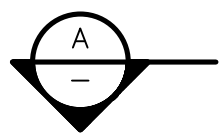

FRONT ELEVATION

STORM SEWER CURB
IRON

CITY OF
JACKSONVILLE
STANDARD

N.T.S.

PLATE D-303

DATE DRAWN 4-24-89

REVISED DATE 5-12-94

APPROX. 240 LBS.

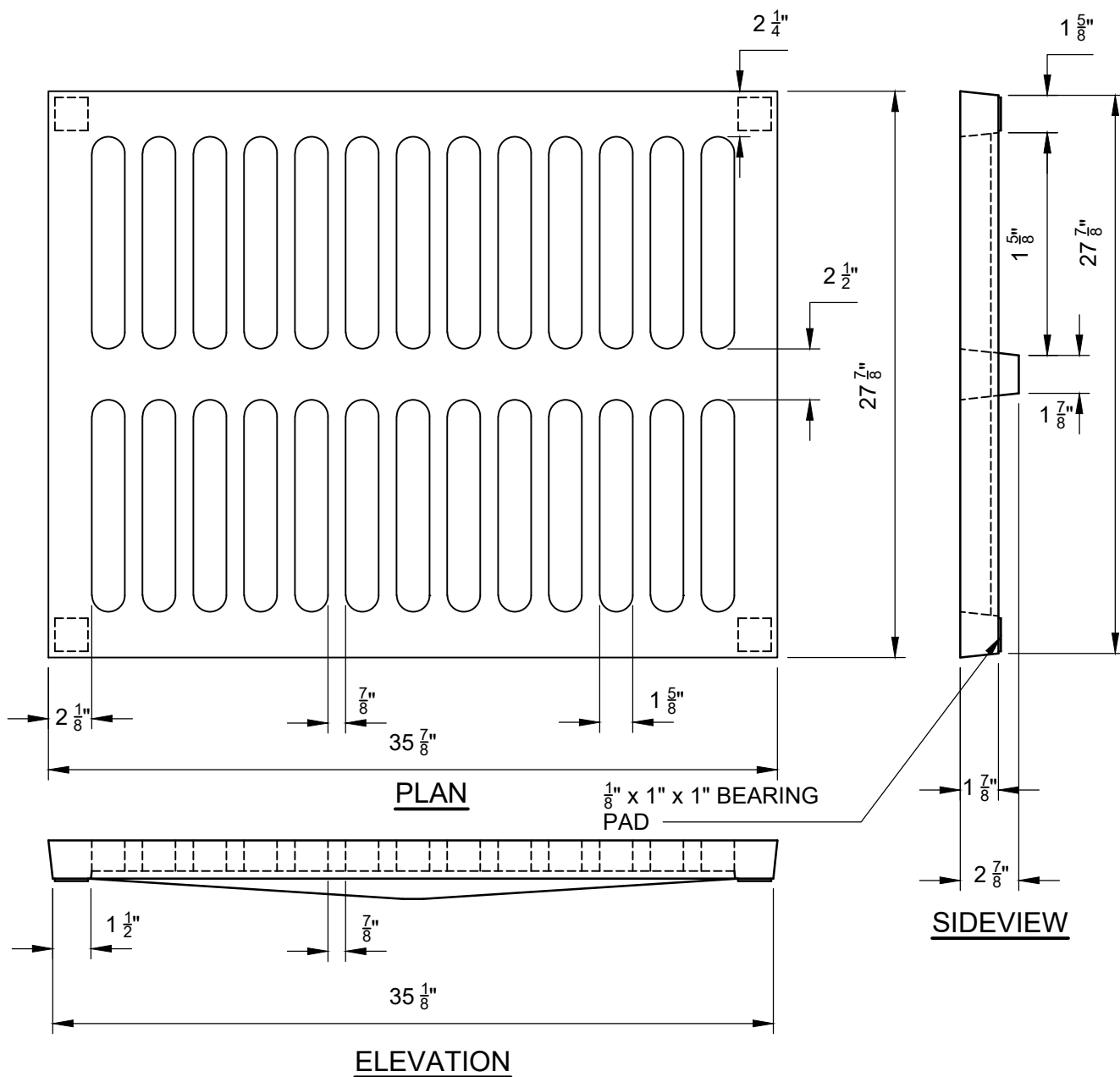

NOTES:

1. STEEL GRATES ARE REQUIRED ON INLETS WITH TRAVERSABLE SLOTS AND ON INLETS WHERE BICYCLE TRAFFIC IS ANTICIPATED.

STORM SEWER INLET GRATE	CITY OF JACKSONVILLE STANDARD	N.T.S.	PLATE D-304
		DATE DRAWN 05-07-90	
		REVISED DATE 11-21-24	

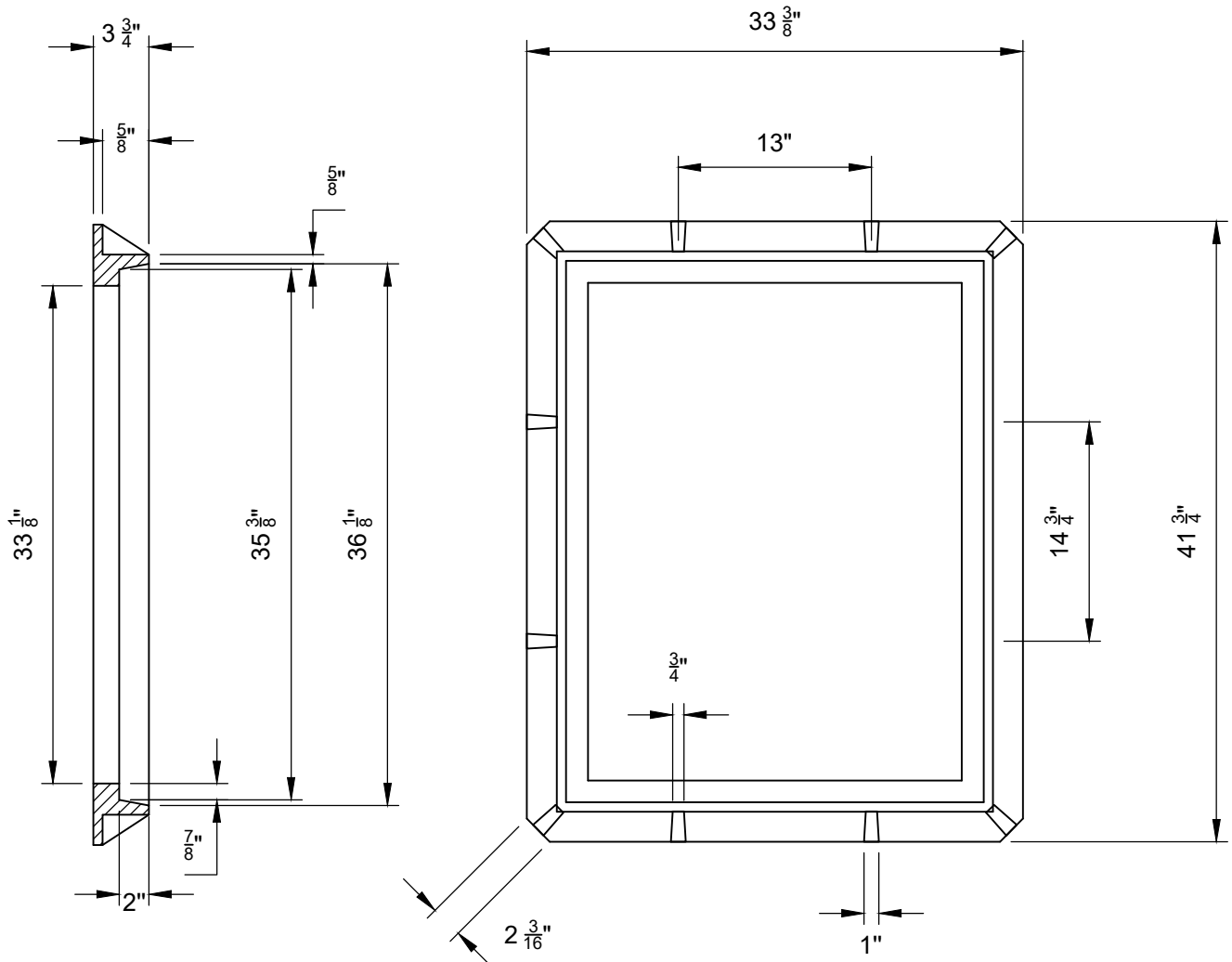

SECTION

PLAN

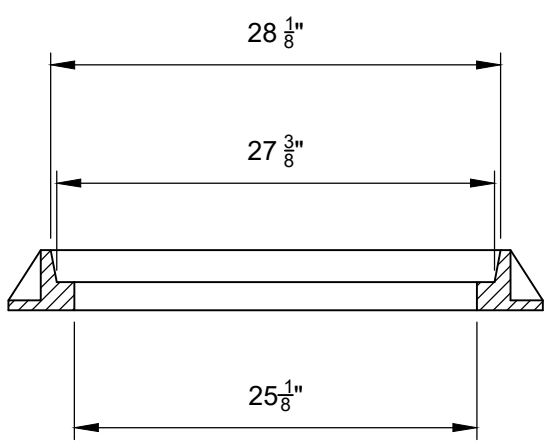

SECTION

APPROX. 220 LBS.

STORM SEWER CATCH BASIN FRAME	CITY OF JACKSONVILLE STANDARD	N.T.S.	PLATE D-305
		DATE DRAWN	3-12-79
		REVISED DATE	11-21-24

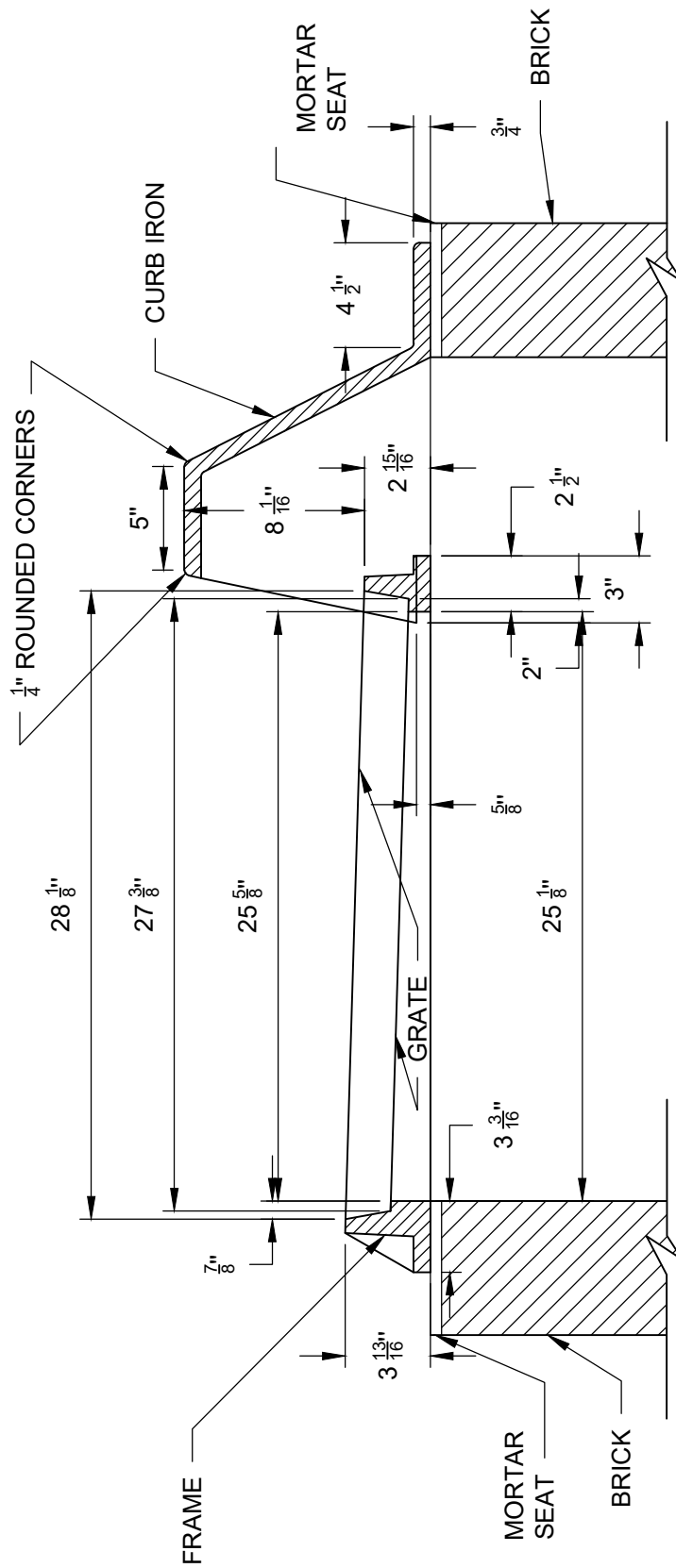

CURB IRON WITH GRATE & FRAME

CITY OF JACKSONVILLE STANDARD

N.T.S.

PLATE D-306

DATE DRAWN 9-9-75

REVISED DATE 11-21-24

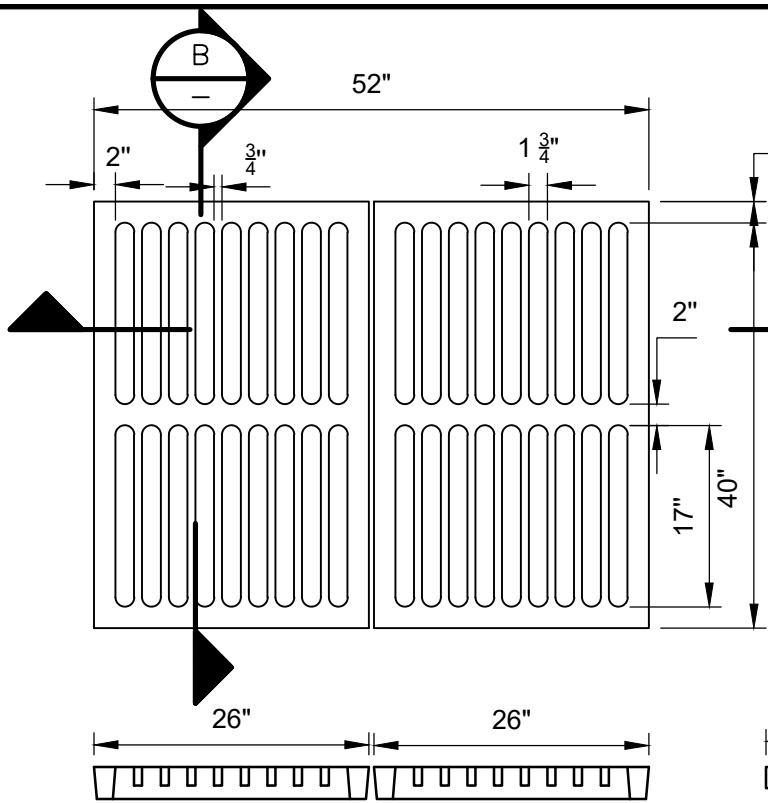

**NON-TRAFFIC BEARING GRATE
FOR TYPE "E" INLET**

NOTE: 2 GRATES SHOWN EACH
GRATE SHALL HAVE A MIN.
WEIGHT OF 240 LBS.

SECTION A-A

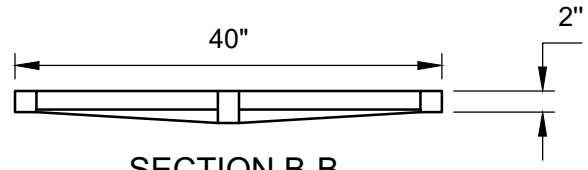

SECTION B-B

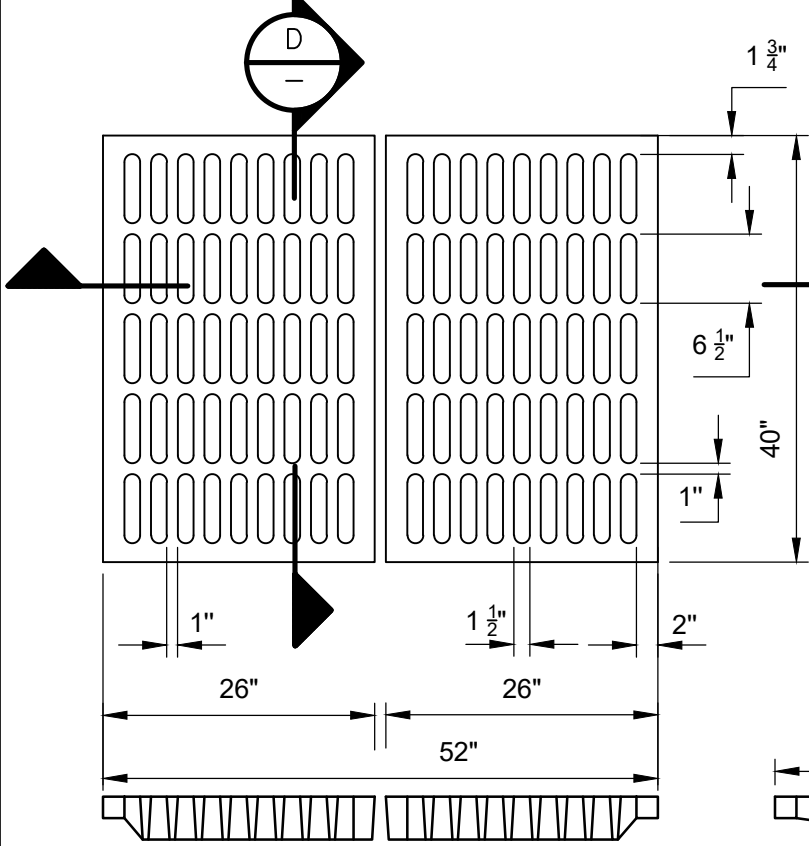

**TRAFFIC BEARING GRATE FOR
TYPE "E" INLET**

NOTE: 2 GRATES SHOWN EACH
GRATE SHALL HAVE A MIN.
WEIGHT OF 316 LBS.

SECTION C-C

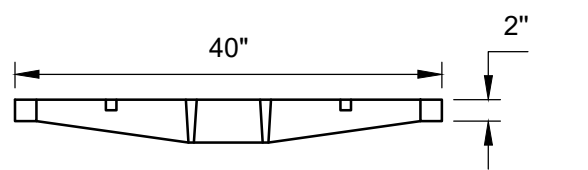

SECTION D-D

GRATE DETAIL FOR TYPE
"E" INLET

CITY OF
JACKSONVILLE
STANDARD

N.T.S.

PLATE D-307

DATE DRAWN 5-16-89

REVISED DATE 11-21-24

2 CONCEALED PICKHOLES

RAISED LETTERS 1 1/2" HIGH FLUSH WITH TOP OF COVER.

RAISED LETTERS 1" HIGH FLUSH WITH TOP OF COVER & SANITARY STRUCTURES TO BE LABELED SANITARY SEWER

COVER DETAIL

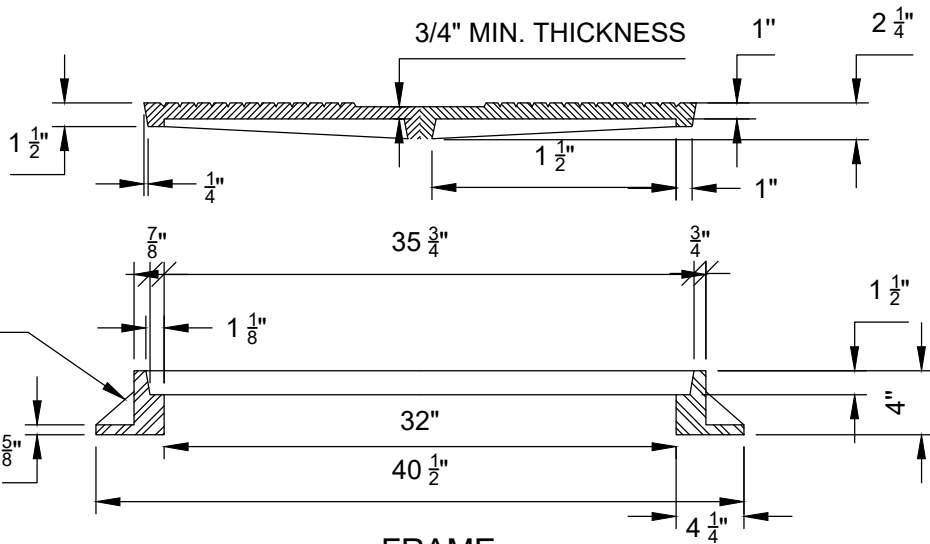
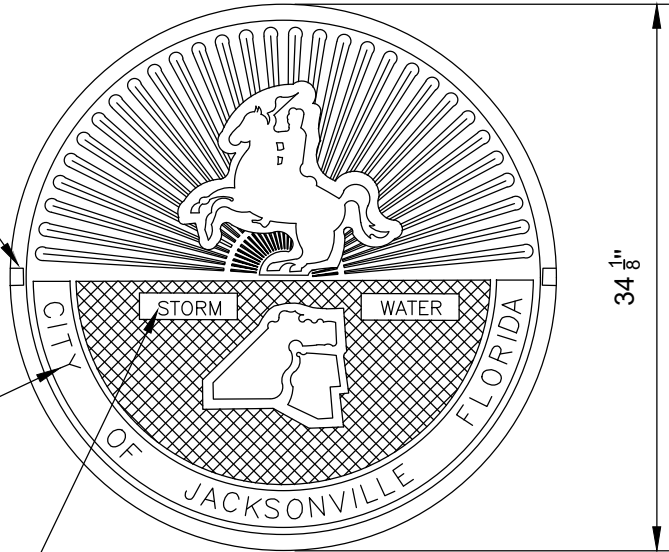

FRAME
(215 LBS. APPROX.)

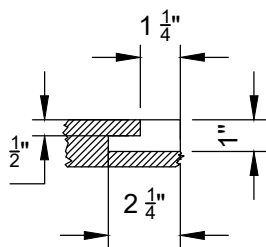

PICKHOLE DETAILS

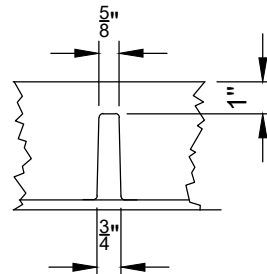
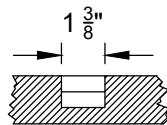

RIB DETAIL

M/H COVER DETAIL

CITY OF JACKSONVILLE STANDARD

N.T.S.

PLATE D-308

DATE DRAWN 07-01-82

REVISED DATE 11-21-24

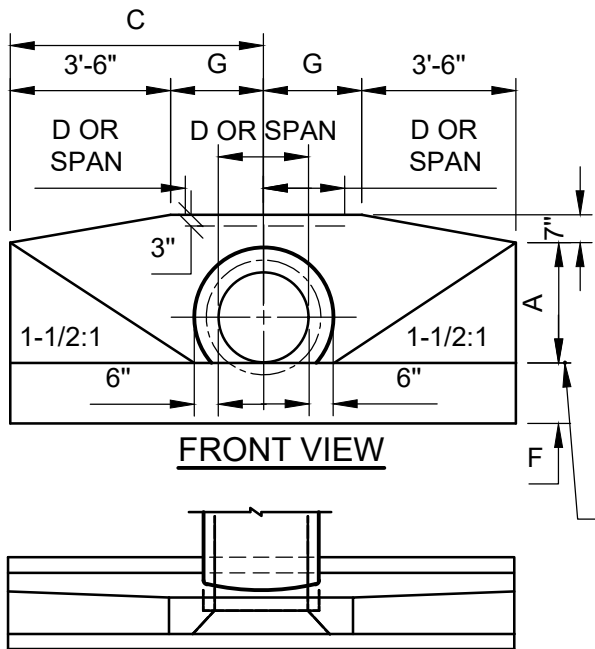

FRONT VIEW

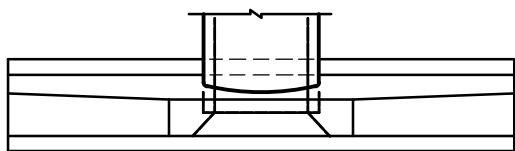

TOP VIEW

ENDWALL DIMENSIONS
(EXCLUSIVE OF MULTIPLE PIPE SPACING)

CONTROL LINE (CLEAR
ZONE LIMIT)
(INDEPENDENT OF
FRONT SLOPE)

END OF PIPE
(SEE NOTE 9)

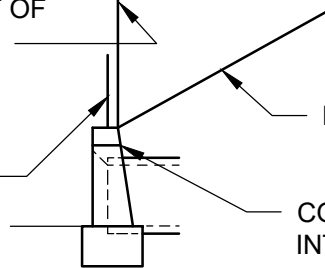

FRONT SLOPE

CONTROL POINT WHEN SLOPE
INTERCEPT OUTSIDE CLEAR ZONE

END VIEW

STANDARD LOCATION CONTROL

1. ENDWALL DIMENSIONS, LOCATIONS AND POSITIONS ARE FOR ROUND AND ELLIPTICAL CONCRETE PIPE AND FOR ROUND AND PIPE-ARCH CORRUGATED METAL PIPE. ROUND CONCRETE PIPE SHOWN. SEE PLATES D-403, 404, & 405 FOR ADDITIONAL DIMENSIONS.
2. ENDWALLS MAY BE CAST IN PLACE OR PRECAST CONCRETE. REINFORCING STEEL SHALL BE GRADES 40 OR 60. ADDITIONAL REINFORCEMENT NECESSARY FOR HANDLING PRECAST UNITS SHALL BE DETERMINED BY THE CONTRACTOR OR THE SUPPLIER. COST OF REINFORCEMENT SHALL BE INCLUDED IN THE CONTRACT UNIT PRICE FOR CONCRETE, (ENDWALLS).
3. ALL EXPOSED CORNERS AND EDGES OF CONCRETE ARE TO BE CHAMFERED 3/4".
4. CONCRETE MEETING THE REQUIREMENTS OF ASTM C-478 (4000 PSI) MAY BE USED IN LIEU OF CLASS ~ CONCRETE IN PRECAST ITEMS MANUFACTURED IN PLANTS WHICH ARE UNDER THE STANDARD OPERATING PROCEDURES FOR THE INSPECTION OF PRECAST DRAINAGE PRODUCTS.
5. ON OUTFALL DITCHES WITH SIDE SLOPES FLATTER THAN 1 1/2:1 PROVIDE 20' TRANSITIONS FROM THE ENDWALL TO THE FLATTER SIDE SLOPES, RIGHT OF WAY PERMITTING.
6. PIPE LENGTH PLAN QUANTITIES SHALL BE BASED ON THE PIPE END LOCATIONS SHOWN IN THE STANDARD LOCATION CONTROL END VIEW, OR LENGTHS BASED ON SPECIAL ENDWALL LOCATIONS CALLED FOR IN THE PLANS.

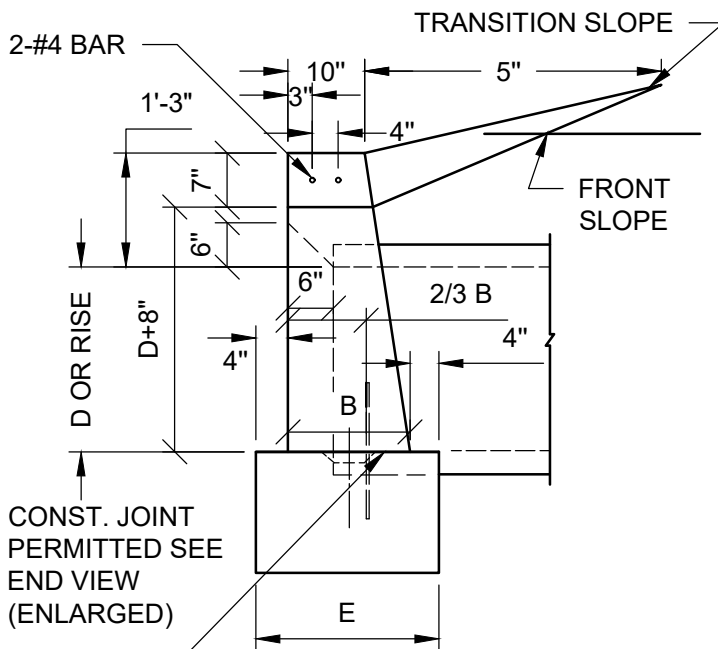

CONST. JOINT
PERMITTED SEE
END VIEW
(ENLARGED)

CONST. JOINT PERMITTED
(KEYWAY & DOWELS
REQUIRED-DOWELS #4 BARS, 18"
WITH 9" EMBEDMENT @ 12" C. TO
C. FOR BAR GRADE AND PAYMENT
SEE NOTE 3.)

END VIEW (ENLARGED)

STRAIGHT CONCRETE
ENDWALLS-SINGLE AND
MULTIPLE PIPE

CITY OF
JACKSONVILLE
STANDARD

N.T.S.

PLATE D-401

DATE DRAWN 8-11-79

REVISED DATE 11-21-24

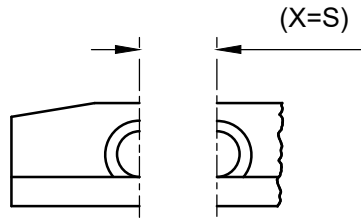

FRONT VIEW

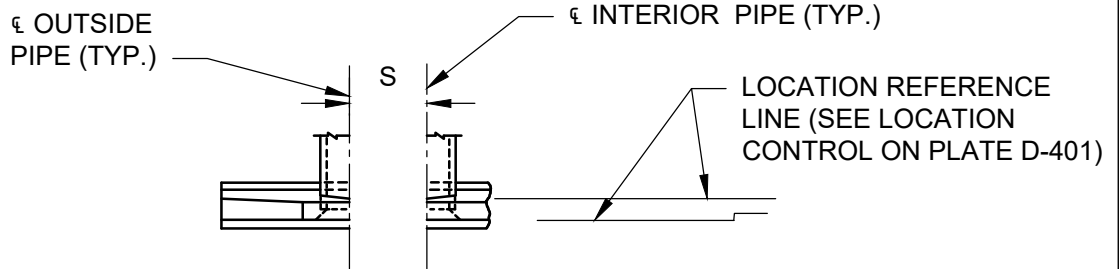

TOP VIEW
NORMAL PIPE

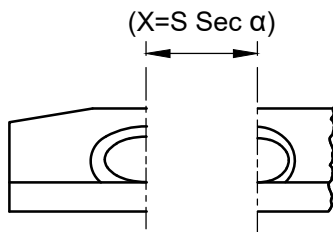

FRONT VIEW

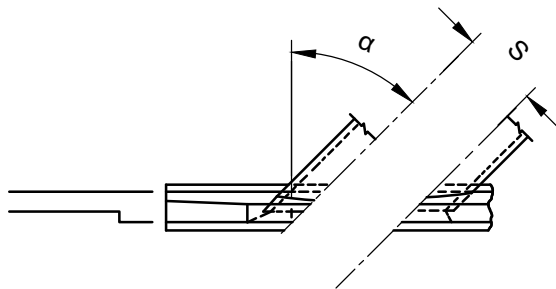

TOP VIEW
SKEWED PIPE

LEGEND

- α PIPE SKEW
- S CENTER TO CENTER PIPE SPACING
- X CENTERLINE TO CENTERLINE DIMENSION AT FACE OF HEADWALL

ENDWALL POSITIONS FOR SINGLE AND MULTIPLE PIPE AND SPACING FOR MULTIPLE PIPE

STRAIGHT CONCRETE
ENDWALLS-SINGLE AND
MULTIPLE PIPE

CITY OF
JACKSONVILLE
STANDARD

N.T.S.

PLATE D-402

DATE DRAWN 8-11-79

REVISED DATE 11-21-24

ROUND CONCRETE AND CORRUGATED METAL PIPE																
D	OPENING AREA (SF)				DIMENSIONS								DIMENSIONS			
	NUMBER OF PIPES				A	B	C	E	F	G	S	X				
	1	2	3	4								0°	15°	30°	45°	
15"	1.23	2.46	3.69	4.92	1'-11"	1'-2"	4'-0"	1'-10"	1'-2"	0'-6"	2'-7"	2'-7"	2'-8"	3'-0"	3'-8"	
18"	1.77	3.54	5.31	7.08	2'-2"	1'-3"	4'-6"	1'-11"	1'-3"	1'-0"	2'-10"	2'-10"	2'-11"	3'-3"	4'-0"	
24"	3.14	6.28	9.42	12.56	2'-8"	1'-4"	5'-6"	2'-0"	1'-4"	2'-0"	3'-5"	3'-5"	3'-6"	3'-11"	4'-10"	
30"	4.91	9.82	14.73	19.64	3'-2"	1'-6"	6'-6"	2'-2"	1'-6"	3'-0"	4'-3"	4'-3"	4'-5"	4'-11"	6'-0"	
36"	7.07	14.14	21.21	28.28	3'-8"	1'-8"	7'-6"	2'-4"	1'-8"	4'-0"	5'-1"	5'-1"	5'-3"	5'-10"	7'-2"	
42"	9.62	19.24	28.86	38.48	4'-2"	1'-10"	8'-6"	2'-6"	2'-0"	5'-0"	6'-0"	6'-0"	6'-3"	6'-11"	8'-6"	
48"	12.57	25.14	37.71	50.28	4'-8"	2'-1"	9'-6"	2'-9"	2'-0"	6'-0"	6'-9"	6'-9"	7'-0"	7'-10"	9'-7"	
54"	15.90	31.80	47.70	63.60	5'-2"	2'-6"	10'-6"	3'-2"	2'-3"	7'-0"	7'-8"	7'-8"	7'-11"	8'-10"	10'-10"	

CONCRETE (CY)										
NUMBER AND TYPE OF PIPE AND SKEW ANGLE OF PIPE										
D	DOUBLE									
	SINGLE	DOUBLE								
	CONC.	METAL	CONC.				METAL			
	0°	0°	0°	15°	30°	45°	0°	15°	30°	45°
15"	1.23	1.24	1.59	1.60	1.65	1.74	1.62	1.63	1.68	1.78
18"	1.56	1.59	1.99	2.01	2.06	2.17	2.04	2.06	2.11	2.23
24"	2.24	2.29	2.82	2.84	2.91	3.06	2.91	2.93	3.01	3.17
30"	3.26	3.34	4.13	4.16	4.26	4.49	4.28	4.31	4.43	4.67
36"	4.53	4.64	5.73	5.77	5.92	6.23	5.95	6.00	6.15	6.49
42"	6.33	6.49	8.11	8.17	8.39	8.85	8.43	8.50	8.73	9.23
48"	8.15	8.38	10.40	10.48	10.75	11.33	12.64	12.80	13.34	14.50
54"	11.71	11.77	15.23	15.35	15.78	16.69				

CONCRETE (CY)									
NUMBER AND TYPE OF PIPE AND SKEW ANGLE OF PIPE									
D	TRIPLE								
	CONC.					METAL			
	0°	15°	30°	45°	0°	15°	30°	45°	
	15"	1.94	1.96	2.05	2.23	1.99	2.02	2.11	2.30
18"	2.43	2.46	2.56	2.79	2.51	2.54	2.65	2.89	
24"	3.39	3.43	3.57	3.87	3.52	3.56	3.71	4.03	
30"	4.98	5.04	5.25	5.69	5.20	5.27	5.49	5.97	
36"	6.92	7.00	7.29	7.91	7.25	7.34	7.65	8.33	
42"	9.90	10.02	10.45	11.38	10.38	10.52	10.98	11.99	
48"	12.64	12.80	13.34	14.50	13.34	13.51	14.11	15.39	
54"	18.77	19.02	19.86	21.69					

CONCRETE (CY)									
NUMBER AND TYPE OF PIPE AND SKEW ANGLE OF PIPE									
D	QUADRUPLE								
	CONC.					METAL			
	0°	15°	30°	45°	0°	15°	30°	45°	
	15"	2.30	2.34	2.47	2.74	2.37	2.41	2.75	2.84
18"	2.86	2.91	3.06	3.40	2.96	3.01	3.17	3.53	
24"	3.97	4.03	4.24	4.69	4.14	4.20	4.43	4.91	
30"	5.84	5.93	6.24	6.91	6.13	6.23	6.56	7.29	
36"	8.13	8.26	8.69	9.62	8.57	8.71	9.18	10.20	
42"	11.68	11.87	12.51	13.89	12.32	12.52	13.22	14.73	
48"	14.89	15.13	15.93	17.68	15.82	16.08	16.97	18.90	
54"	22.29	22.66	23.93	26.67					

STRAIGHT CONCRETE ENDWALLS SINGLE AND MULTIPLE PIPE	CITY OF JACKSONVILLE STANDARD	N.T.S.	PLATE D-403
		DATE DRAWN	07-14-79
		REVISED DATE	11-21-24

CORRUGATED METAL PIPE ARCH																
SPAN	RISE	OPENING AREA (SF)				DIMENSIONS							X			
		NUMBER OF PIPES				A	B	C	E	F	G	S	0°	15°	30°	45°
		1	2	3	4											
17"	13"	1.1	2.2	3.3	4.4	1'-9"	1'-2"	3'-10"	1'-10"	1'-2"	0'-4"	2'-6"	2'-6"	2'-7"	2'-11"	3'-6"
21"	15"	1.6	3.2	4.8	6.4	1'-11"	1'-2"	4'-3"	1'-10"	1'-2"	0'-9"	2'-10"	2'-10"	2'-11"	3'-3"	4'-0"
28"	20"	2.8	5.6	8.4	11.2	2'-4"	1'-3"	5'-2"	1'-11"	1'-3"	1'-8"	3'-5"	3'-5"	3'-6"	3'-11"	4'-10"
35"	24"	4.3	8.6	12.9	17.2	2'-8"	1'-4"	5'-11 1/2"	2'-0"	1'-4"	2'-5 1/2"	4'-0"	4'-0"	4'-2"	4'-7"	5'-8"
42"	29"	5.9	11.8	17.7	23.6	3'-1"	1'-5"	6'-10 1/2"	2'-1"	1'-5"	3'-4 1/2"	4'-9"	4'-9"	4'-11"	5'-6"	6'-9"
49"	33"	8.4	16.8	25.2	33.6	3'-5"	1'-6"	7'-8"	2'-2"	1'-6"	4'-2"	5'-6"	5'-6"	5'-8"	6'-4"	7'-9"
57"	38"	10.6	21.2	31.8	42.4	3'-10"	1'-7"	8'-7 1/2"	2'-3"	1'-7"	5'-1 1/2"	6'-4"	6'-4"	6'-7"	7'-4"	8'-11"
64"	43"	13.2	26.4	39.6	52.8	4'-3"	1'-8"	9'-6 1/2"	2'-4"	1'-8"	6'-0 1/2"	7'-1"	7'-1"	7'-4"	8'-2"	10'-0"
71"	47"	16.9	33.8	50.7	67.6	4'-7"	1'-10"	10'-4"	2'-6"	2'-0"	6'-10"	7'-10"	7'-10"	8'-1"	9'-1"	11'-1"

CORRUGATED METAL PIPE ARCH															
SPAN	RISE	CONCRETE (CY)													APPOX. EQUIV. ROUND PIPE
		NUMBER OF PIPE AND SKEW ANGLE OF PIPE													
		SINGLE	DOUBLE				TRIPLE				QUADRUPLE				
		0°	0°	15°	30°	45°	0°	15°	30°	45°	0°	15°	30°	45°	
17"	13"	1.16	1.47	1.48	1.52	1.60	1.78	1.80	1.88	2.04	2.09	2.12	2.23	2.48	15"
21"	15"	1.33	1.69	1.70	1.75	1.84	2.04	2.06	2.15	2.33	2.40	2.44	2.57	2.84	18"
28"	20"	1.78	2.31	2.33	2.39	2.53	2.83	2.87	2.99	3.26	3.36	3.42	3.60	4.01	18"
35"	24"	2.34	3.03	3.05	3.14	3.32	3.72	3.77	3.93	4.29	4.40	4.47	4.72	5.25	30"
42"	29"	3.13	4.06	4.09	4.20	4.45	4.99	5.06	5.28	5.76	5.93	6.03	6.36	7.09	36"
49"	33"	3.83	5.00	5.04	5.18	5.48	6.16	6.24	6.52	7.12	7.32	7.44	7.86	8.76	42"
57"	38"	4.87	6.31	6.36	6.53	6.91	7.74	7.84	8.18	8.93	9.18	9.33	9.85	11.00	48"
64"	43"	5.88	7.64	7.70	7.91	8.37	9.40	9.52	9.94	10.90	11.20	11.30	12.00	13.30	54"
71"	47"	7.80	10.20	10.20	10.50	11.10	12.50	12.70	13.20	14.40	14.90	15.10	15.90	17.80	60"

STRAIGHT CONCRETE ENDWALLS SINGLE AND MULTIPLE PIPE	CITY OF JACKSONVILLE STANDARD	N.T.S.	PLATE D-404
		DATE DRAWN	07-13-79
		REVISED DATE	11-21-24

SPAN	RISE	OPENING AREA (SF)				CONCRETE ELLIPTICAL PIPE										
						DIMENSIONS								X		
		NUMBER OF PIPES				A	B	C	E	F	G	S	X			
		1	2	3	4								0°	15°	30°	45°
18"	12"	1.3	2.6	3.9	5.2	1'-8"	1'-2"	3'-9"	1'-10"	1'-2"	0'-3"	2'-10"	2'-10"	2'-11"	3'-3"	4'-0"
23"	14"	1.8	3.6	5.4	7.2	1'-10"	1'-3"	4'-21/2"	1'-11"	1'-3"	81/2"	3'-5"	3'-5"	3'-6"	3'-11"	4'-10"
30"	19"	3.3	6.6	9.9	13.2	2'-3"	1'-4"	5'- 11/2"	2'-0"	1'-4"	1'-71/2"	4'-2"	4'-2"	4'-4"	4'-10"	5'-11"
38"	24"	5.1	10.2	15.3	20.4	2'-8"	1'-5"	6'-3"	2'-1"	1'-5"	2'-9"	5'-2"	5'-2"	5'-4"	6'-0"	7'-4"
45"	29"	7.4	14.8	22.2	29.6	3'-1"	1'-6"	7'-0"	2'-2"	1'-6"	3'-6"	6'-0"	6'-0"	6'-3"	6'-11"	8'-6"
53"	34"	10.2	20.4	30.6	40.8	3'-6"	1'-7"	7'-111/2"	2'-3"	1'-7"	4'-51/2"	7'-1"	7'-1"	7'-4"	8'-2"	10'-0"
60"	38"	12.9	25.8	38.7	51.6	3'-10"	1'-8"	8'-9"	2'-4"	1'-8"	5'-3"	7'-11"	7'-11"	8'-2"	9'-2"	11'-2"
68"	43"	16.6	33.2	49.8	66.4	4'-3"	1'-10"	9'-81/2"	2'-6"	1'-10"	6'-21/2"	8'-10"	8'-10"	9'-2"	10'-2"	12'-6"
76"	48"	20.5	41.0	61.5	82.0	4'-8"	2'-1"	10'-8"	2'-9"	2'-0"	7'-2"	9'-9"	9'-9"	10'-1"	11'-3"	13'-9"
* 83"	53"	24.8	49.6	74.4	99.2	5'-1"	2'-6"	11'-7"	3'-2"	2'-6"	8'-1"	10'-7"	10'-7"	10'-11"	12'-3"	15'-0"
91"	58"	29.5	59.0	88.5	118.0	5'-6"	2'-10"	12'-61/2"	3'-6"	2'-10"	9'-01/2"	11'-4"	11'-4"	11'-9"	13'-1"	16'-0"

CONCRETE ELLIPTICAL PIPE															
SPAN	RISE	CONCRETE (CY)													APPOX. EQUIV. ROUND PIPE
		NUMBER OF PIPE AND SKEW ANGLE OF PIPE													
		SINGLE	DOUBLE				TRIPLE				QUADRUPLE				
		0°	0°	15°	30°	45°	0°	15°	30°	45°	0°	15°	30°	45°	
12"	18"	1.09	1.45	1.46	1.51	1.60	1.80	1.82	1.91	2.09	2.16	2.20	2.33	2.60	15"
14"	23"	1.36	1.82	1.84	1.89	2.01	2.29	2.32	2.43	2.68	2.75	2.80	2.97	3.33	18"
19"	30"	1.89	2.55	2.57	2.65	2.82	3.22	3.27	3.43	3.77	3.88	3.95	4.19	4.70	24"
24"	38"	2.64	3.55	3.58	3.69	3.93	4.48	4.54	4.77	5.24	5.39	5.49	5.82	6.53	30"
29"	45"	3.32	4.48	4.52	4.66	4.96	5.64	5.72	6.00	6.60	6.80	6.92	7.34	8.24	36"
34"	53"	4.24	5.76	5.81	6.00	6.39	7.29	7.40	7.76	8.55	8.81	8.97	9.52	10.70	42"
38"	60"	5.22	7.16	7.23	7.46	7.96	9.10	9.24	9.70	10.70	11.10	11.20	12.00	13.50	48"
43"	68"	6.63	9.01	9.09	9.38	10.00	11.40	11.60	12.10	13.40	13.80	14.00	14.90	16.70	54"
48"	76"	8.66	11.70	11.80	12.20	13.00	14.80	15.00	15.80	17.40	17.90	18.20	19.30	21.70	60"
* 53"	83"	12.50	16.90	16.90	17.70	18.80	21.50	21.80	22.90	25.20	26.00	26.40	28.10	31.60	66"
58"	91"	16.50	22.30	22.50	23.20	24.70	28.00	28.50	29.90	32.90	33.90	34.50	36.60	41.00	72"

* SPECIAL ORDER; NOT STANDARD SIZE

STRAIGHT CONCRETE ENDWALLS SINGLE AND MULTIPLE PIPE	CITY OF JACKSONVILLE STANDARD	N.T.S.	PLATE D-405
		DATE DRAWN	07-13-79
		REVISED DATE	11-21-24

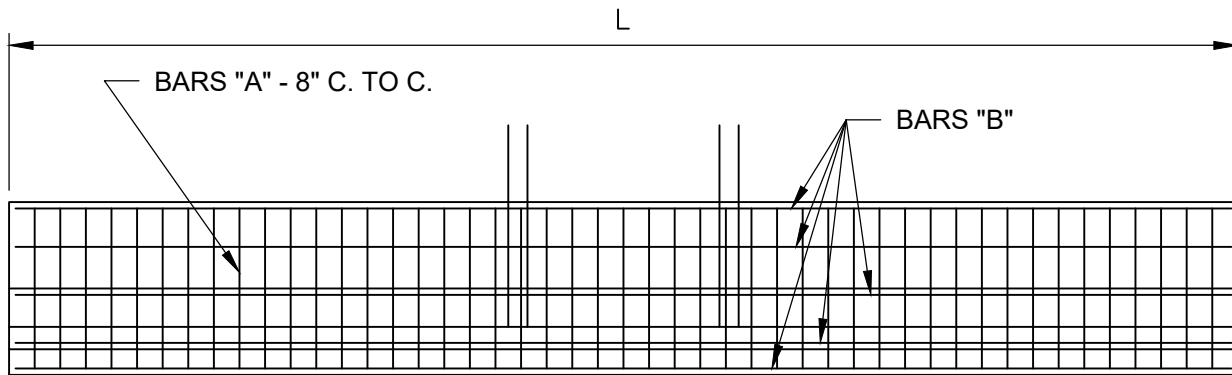

PLAN - SHOWING BARS IN FOOTING

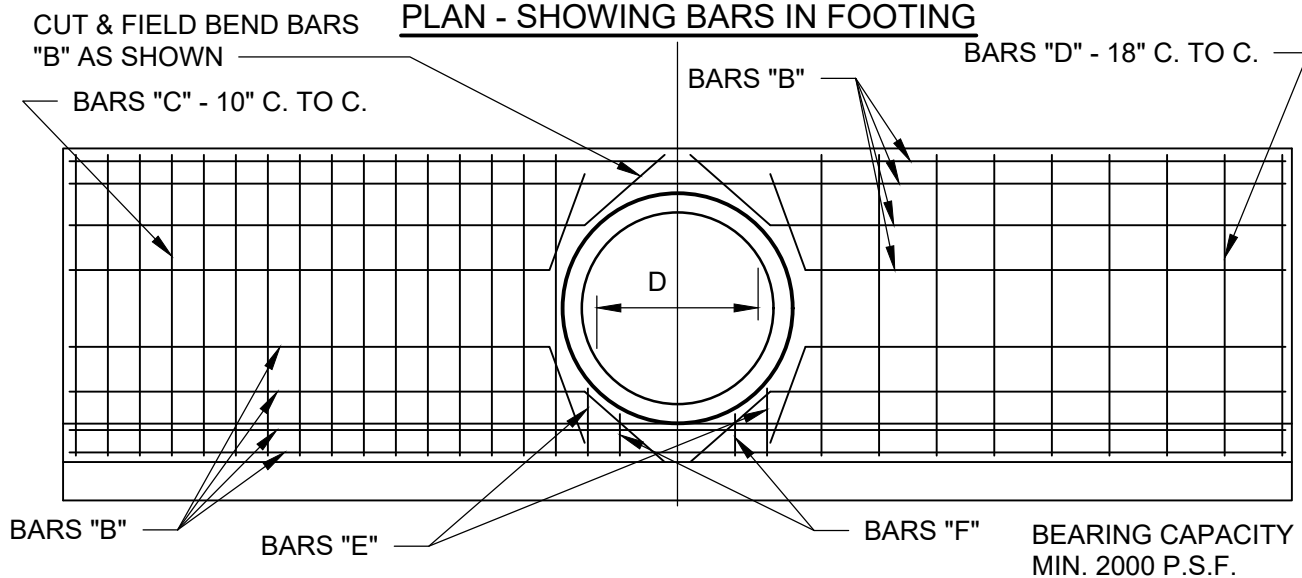

HALF ELEV. SHOWING BARS IN BACK FACE OF WALL

HALF ELEV. SHOWING BARS IN FRONT FACE OF WALL

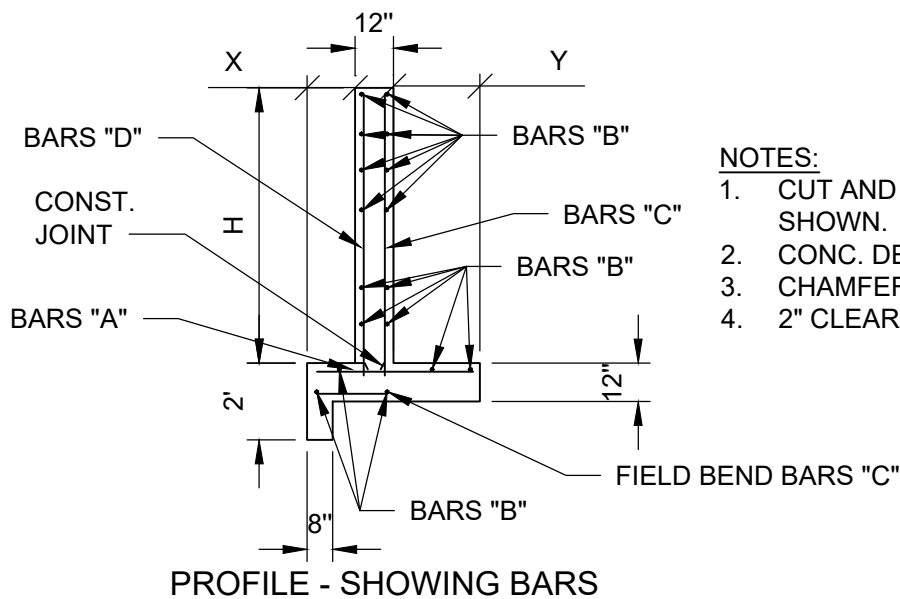

- NOTES:**
1. CUT AND FIELD BEND BARS "B" AS SHOWN.
 2. CONC. DESIGN STRENGTH 3000 P.S.I.
 3. CHAMFER ALL EXPOSED EDGES 3/4".
 4. 2" CLEARANCE ON ALL BARS.

PROFILE - SHOWING BARS

STRAIGHT ENDWALL FOR
60"-78" CONC. PIPE
CULVERTS

CITY OF
JACKSONVILLE
STANDARD

N.T.S.

PLATE D-406

DATE DRAWN 5-8-79

REVISED DATE 11-21-24

STRAIGHT ENDWALLS

DIMENSIONS					BAR SCHEDULE				
PIPE SIZE	L	H	X	Y	BAR	SIZE	LENGTH	NO. REQ.	SPACE
60"	32'-0"	7'-2"	1'-3"	2'-3"	A	6	4'-2"	48	8"
					B	4	31'-8"	17	
					C	6	9'-9"	32	10"
					D	4	7'-10"	18	18"
					E	6	2'-6"	4	
					F	6	1'-6"	4	
66"	34'-0"	7'-8"	1'-3"	2'-8"	A	6	4'-7"	51	8"
					B	4	33'-8"	17	
					C	6	10'-3"	34	10"
					D	4	8'-4"	20	18"
					E	6	2'-6"	4	
					F	6	1'-6"	4	
72"	36'-0"	8'-3"	1'-4"	3'-1"	A	6	5'-1"	54	8"
					B	4	35'-8"	17	
					C	6	10'-11"	36	10"
					D	4	8'-11"	22	18"
					E	6	2'-6"	4	
					F	6	1'-6"	4	
78"	38'-0"	8'-10"	1'-4"	3'-8"	A	6	5'-8"	57	8"
					B	4	37'-8"	17	
					C	6	11'-6"	38	10"
					D	4	9'-6"	22	18"
					E	6	2'-6"	4	
					F	6	1'-6"	4	

ESTIMATED QUANTITIES		
PIPE SIZE	CONC. (CU. YDS.)	STEEL (LBS.)
60"	13.58	1247
66"	15.44	1392
72"	17.63	1563
78"	20.07	1733

DIMENSIONAL AND QUANTITATIVE DATA FOR 60"-78" CONC. PIPE ENDWALLS	CITY OF JACKSONVILLE STANDARD	N.T.S.	PLATE D-407
		DATE DRAWN	5-9-79
		REVISED DATE	11-21-24

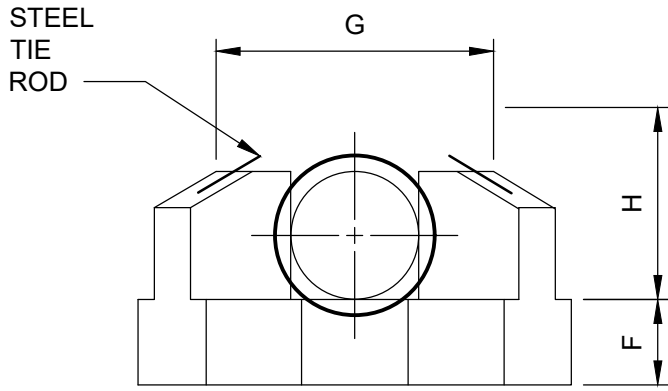

FRONT ELEVATION

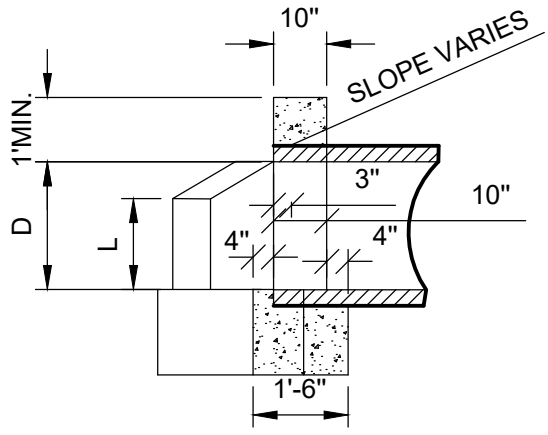

SECTION N-N

NOTE:

1. CHAMFER ALL EXPOSED EDGES 3/4" MIN.
2. BEARING CAPACITY 2000 P.S.I.
3. WHERE TIE RODS ARE REQUIRED, THE COST SHALL BE INCLUDED IN THE UNIT BID PRICE.
4. CONCRETE DESIGN STRENGTH 3000 P.S.I.

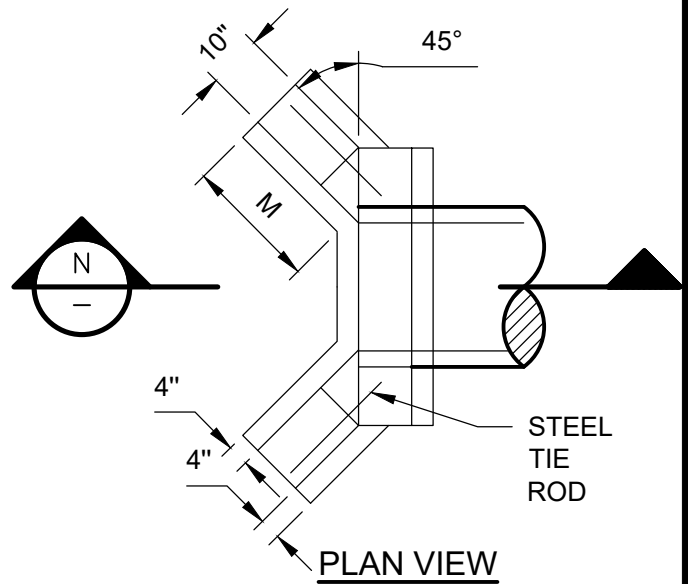

PLAN VIEW

DIMENSIONS							QUANTITIES IN ONE ENDWALL			
OPENING		WALL				FOOTING	CONCRETE 3,000 P.S.I.			STEEL
D	AREA SQ. FT.	H	G	L	M	F	TOTAL CU. YARDS			TIE RODS
							CONC. PIPE	C.M. PIPE	C.I. PIPE	
15"	1.2	2'-3"	3'-7"	1'-0"	1'-3"	1'-3"	0.58	0.61	0.61	NONE
18"	1.8	2'-6"	3'-10"	1'-2"	1'-7"	1'-3"	0.76	0.79	0.79	NONE
24"	3.1	3'-0"	4'-4"	1'-5"	2'-1"	1'-4"	1.03	1.08	1.08	2-3/4"ØX2'-0"
30"	4.9	3'-6"	4'-10"	1'-9"	2'-5"	1'-6"	1.34	1.42	1.41	2-3/4"ØX2'-0"
36"	7.1	4'-0"	5'-4"	2'-0"	2'-11"	1'-8"	1.74	1.85	1.84	2-3/4"ØX3'-0"
42"	9.6	4'-6"	5'-10"	2'-3"	3'-5"	2'-0"	2.36	2.49		2-3/4"ØX3'-0"
48"	12.6	5'-0"	6'-4"	2'-6"	4'-0"	2'-0"	2.76	2.92		2-3/4"ØX3'-0"

CONCRETE ENDWALL WITH
45° WINGS FOR PIPE
CULVERTS

**CITY OF
JACKSONVILLE
STANDARD**

N.T.S.

PLATE D-408

DATE DRAWN 7-12-79

REVISED DATE 11-21-24

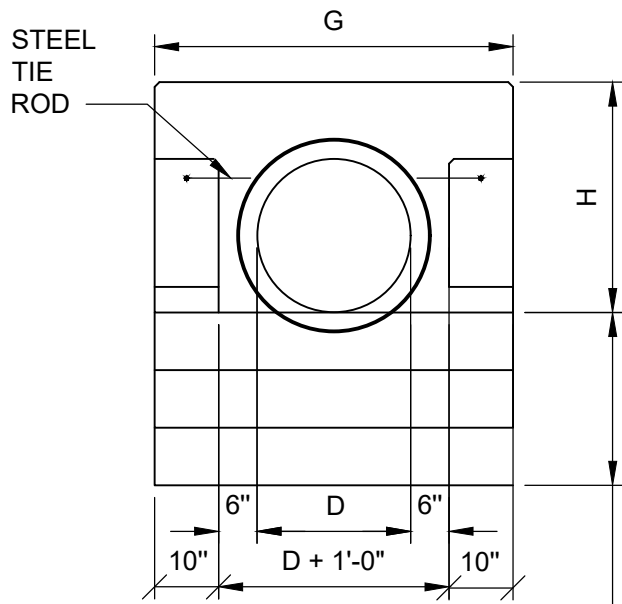

FRONT ELEVATION

F + 9" FOR
OUTLET
END ONLY

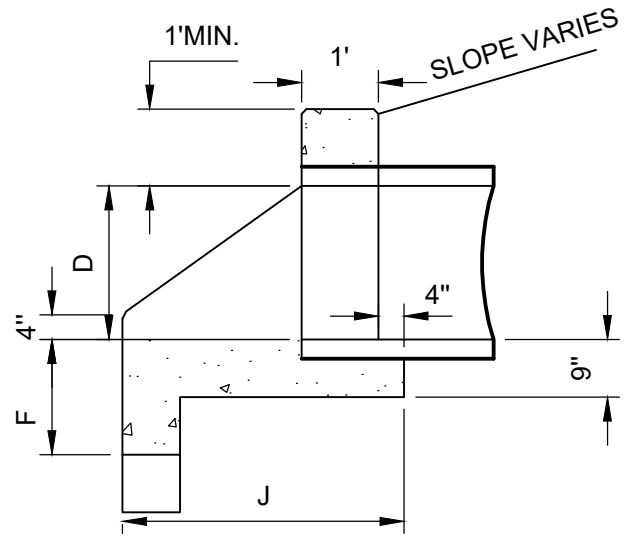

SECTION R-R

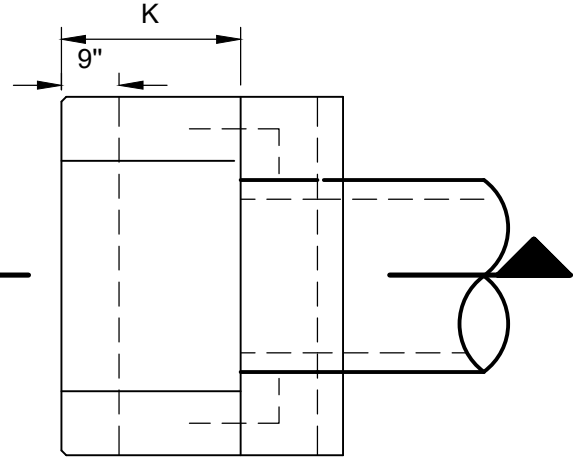

PLAN VIEW

NOTE:

1. CHAMFER ALL EXPOSED EDGES 3/4" MIN.
2. BEARING CAPACITY 2000 P.S.I.
3. WHERE TIE RODS ARE REQUIRED, THE COST SHALL BE INCLUDED IN THE UNIT BID PRICE.
4. CONCRETE DESIGN STRENGTH 3000 P.S.I.

TABLE OF DIMENSIONS AND ESTIMATED QUANTITIES
PIPE CULVERT ENDWALLS WITH U-TYPE WINGS

DIMENSIONS							QUANTITIES IN ONE ENDWALL						
OPENING		WALL			FOOTING		TOTAL CU. YDS. CONCRETE, 3000 P.S.I.				STEEL TIE RODS		
D	AREA SQ.FT.	G	H	K	F	J	CONC. PIPE		C.M. PIPE			C.I. PIPE	
							INLET	OUTLET	INLET	OUTLET		INLET	OUTLET
12"	0.8	3'-8"	2'-0"	1'-0"	1'-3"	2'-4"	0.50	0.57	0.51	0.59	0.51	0.59	NONE
15"	1.2	3'-11"	2'-3"	1'-5"	1'-3"	2'-9"	0.61	0.69	0.64	0.72	0.63	0.72	NONE
18"	1.8	4'-2"	2'-6"	1'-9"	1'-3"	3'-1"	0.72	0.81	0.76	0.84	0.76	0.84	NONE
24"	3.1	4'-8"	3'-0"	2'-6"	1'-6"	3'-10"	1.03	1.13	1.08	1.18	1.08	1.18	2-3/4" Ø x 2'-0"
30"	4.9	5'-2"	3'-6"	3'-3"	1'-6"	4'-7"	1.35	1.46	1.43	1.53	1.42	1.53	2-3/4" Ø x 2'-0"
36"	7.1	5'-8"	4'-0"	4'-0"	1'-9"	5'-4"	1.75	1.87	1.86	1.98	1.84	1.96	2-3/4" Ø x 2'-6"
42"	9.6	6'-2"	4'-6"	4'-9"	2'-0"	6'-1"	2.21	2.34	2.34	2.47			2-3/4" Ø x 2'-6"
48"	12.6	6'-8"	5'-0"	5'-6"	2'-0"	6'-10"	2.66	2.80	2.83	2.97			2-3/4" Ø x 3'-0"

CONCRETE ENDWALL WITH
U-TYPE WINGS FOR PIPE
CULVERTS

CITY OF
JACKSONVILLE
STANDARD

N.T.S.

PLATE D-409

DATE DRAWN 7-14-79

REVISED DATE 11-21-24

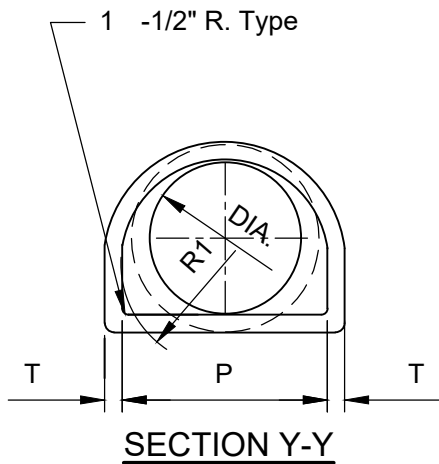
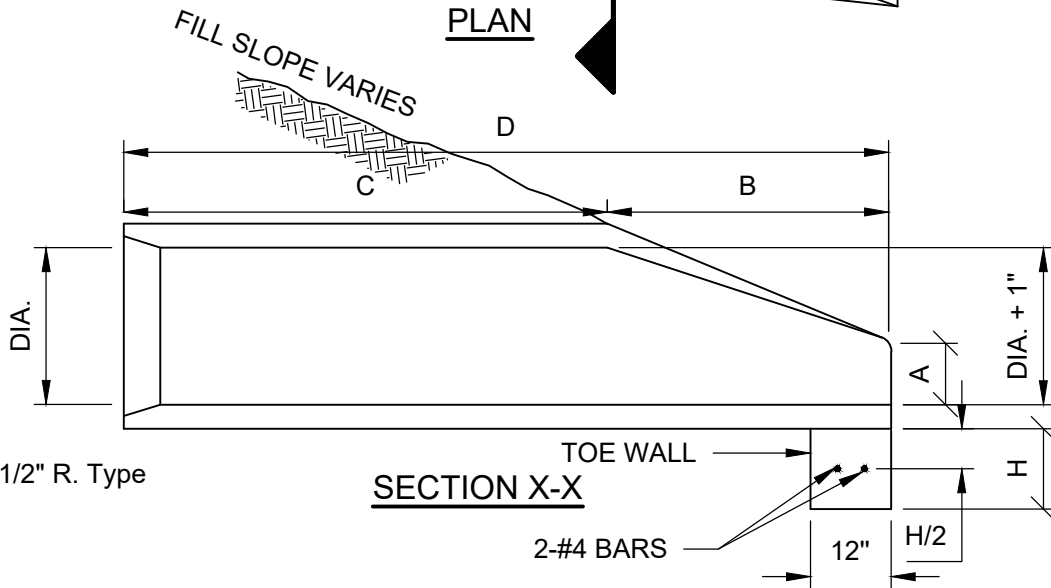
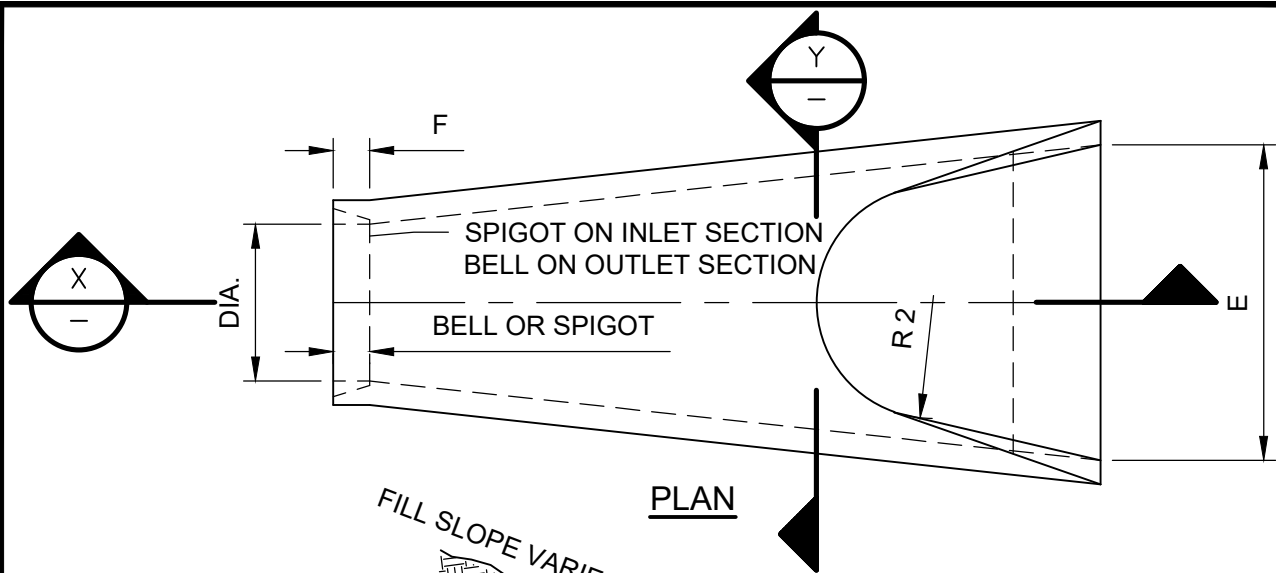

NOTES:

1. END SECTIONS SHALL CONFORM TO STANDARD STRENGTH REINFORCED CONCRETE PIPE OF LIKE DIAMETER AS PER STANDARD SPECIFICATIONS.
2. JOINT BETWEEN END SECTION & PIPE CULVERT TO BE MADE BY REINFORCED CONCRETE COLLAR OR COLD ADHESIVE PREFORMED PLASTIC GASKET.
3. END SECTIONS TO BE USED ONLY WHEN SPECIFIED ON THE PLANS OR AT LOCATIONS AS DIRECTED BY THE ENGINEER.
4. TOE WALL TO BE CONSTRUCTED WHEN SHOWN ON THE PLANS OR DESIGNATED BY THE ENGINEER.

DIA.	T	BELL OR SPIGOT	A	B	C	D	E	P	R1	R2	F	H	WEIGHT (LBS.)
15"	2-1/4"	2"	6"	2'-3"	3'-10"	6'-1"	2'-6"	24-5/16"	12-1/2"	11"	3-1/2"	12"	740
18"	2-1/2"	2-1/2"	9"	2'-3"	3'-10"	6'-1"	3'-0"	29"	15-1/2"	12"	4"	15"	990
24"	3"	2-1/2"	9-1/2"	3'-7 1/2"	2'-6"	6'-1 1/2"	4'-0"	33-3/16"	16-13/16"	14"	4-1/2"	18"	1520
30"	3-1/2"	3"	1'-0"	4'-6"	1'-7 3/4"	6'-1 3/4"	5'-0"	37"	18-1/2"	15"	5"	21"	2190
36"	4"	3-1/2"	1'-3"	5'-3"	2'-10 3/4"	8'-1 3/4"	6'-0"	47-13/16"	24-5/16"	20"	5-1/2"	21"	4100
42"	4-1/2"	3-3/4"	1'-9"	5'-3"	2'-11"	8'-2"	6'-6"	53-7/8"	27-1/2"	22"	5-1/2"	24"	5380
48"	5"	4-1/4"	2'-0"	6'-0"	2'-2"	8'-2"	7'-0"	56-1/2"	28-1/2"	22"	5-3/4"	24"	6550
54"	5-1/2"	4-3/4"	2'-3"	5'-5"	2'-11"	8'-4"	7'-6"	65-1/2"	33-1/8"	24"	6-1/4"	24"	8040
60"	6"	5"	2'-6"	5'-0"	3'-3"	8'-3"	8'-0"	72-1/2"	36-11/16"	24"	6-3/4"	24"	8750
66"	6-1/2"	5-1/2"	2'-0"	6'-6"	1'-9"	8'-3"	8'-6"	72"	36-1/8"	24"	7-1/4"	24"	10630
72"	7"	6"	2'-0"	6'-6"	1'-9"	8'-3"	9'-0"	77-13/16"	3- 15/16"	24"	7-3/4"	24"	12520

FLARED END SECTION
FOR PIPE CULVERTS

CITY OF
JACKSONVILLE
STANDARD

N.T.S.

PLATE D-410

DATE DRAWN

2-5-79

REVISED DATE

11-21-24

2-10"-3/8 GAUGE SPIKES OR 2-12"-#3
REINF. ROD PER BAG TYPICAL

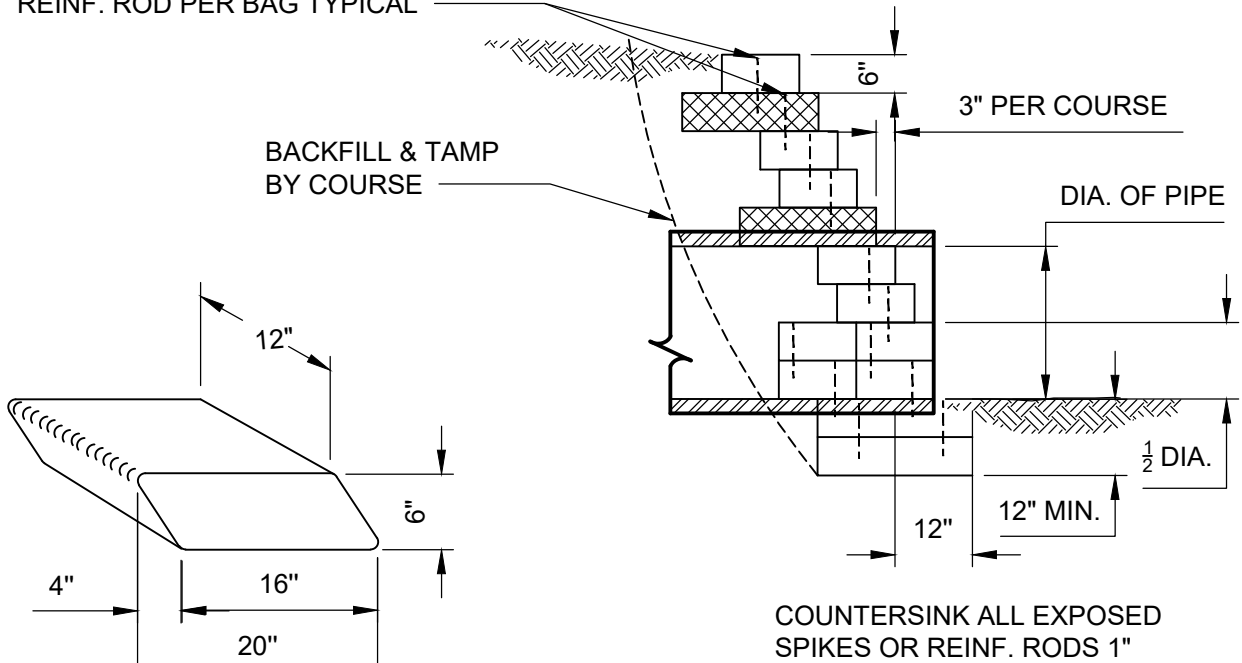

COUNTERSINK ALL EXPOSED
SPIKES OR REINF. RODS 1"

BAG DETAIL

SECTION F-F

TURN EVERY THIRD BAG
OF EVERY THIRD
COURSE INWARD
TOWARD BANK.

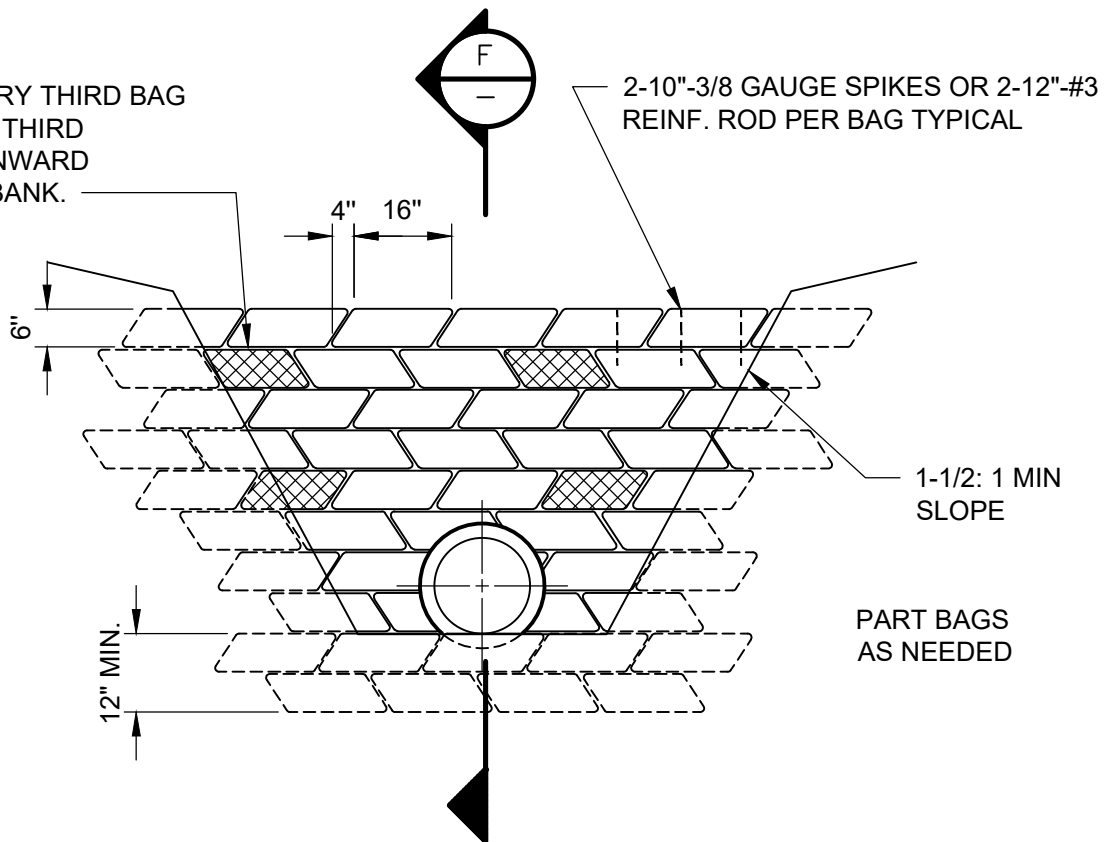

PART BAGS
AS NEEDED

SAND - CEMENT RIP RAP
ENDWALL

CITY OF
JACKSONVILLE
STANDARD

N.T.S.

PLATE D-411

DATE DRAWN 3-18-79

REVISED DATE 11-22-24

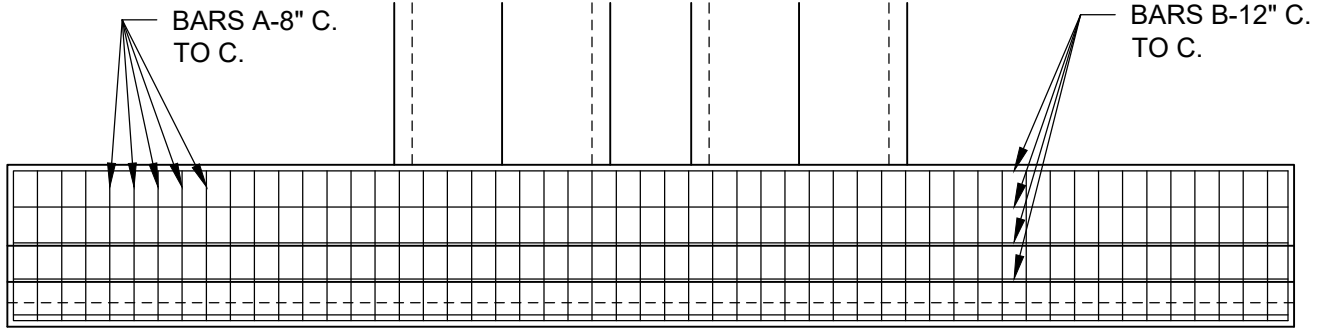

PLAN SHOWING BARS IN FOOTING

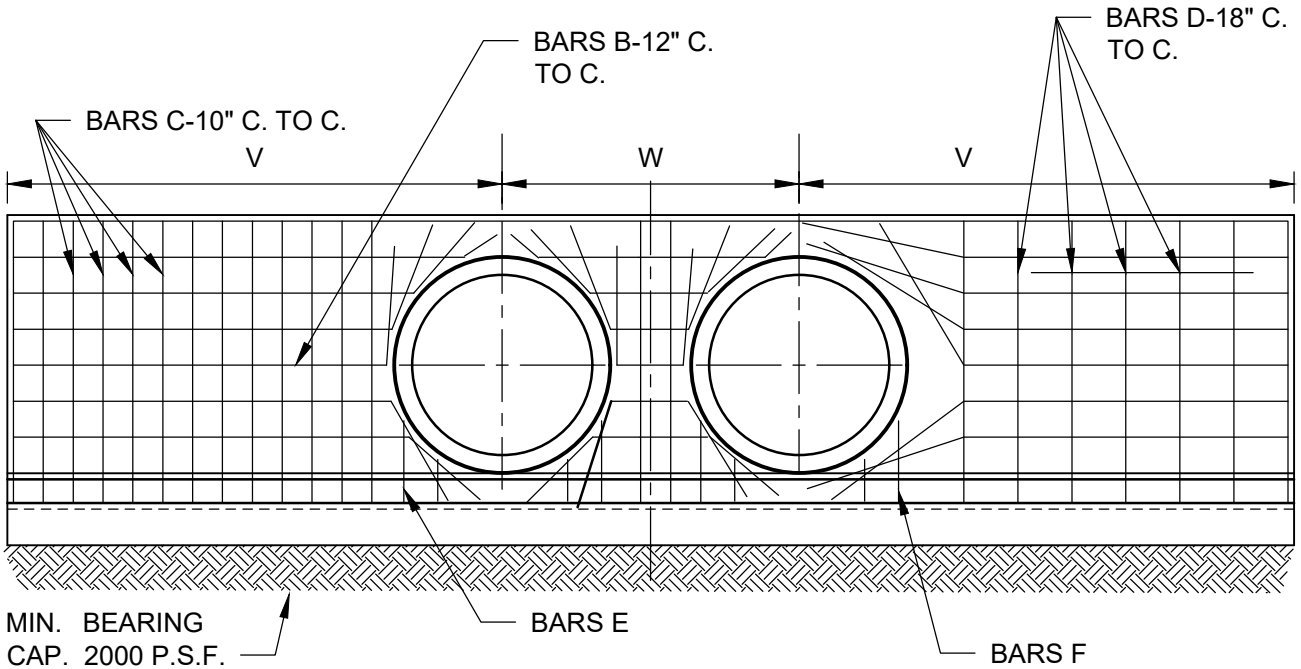

HALF ELEV. SHOWING BARS IN BACK FACE OF WALL

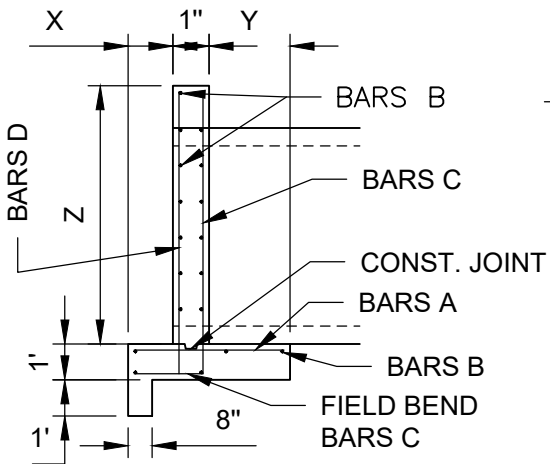

HALF ELEV. SHOWING BARS IN FRONT FACE OF WALL

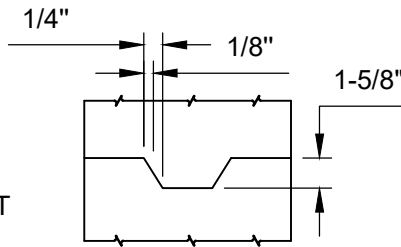

CONST. JOINT DETAIL

NOTES:

- 1) CUT & FIELD BEND BARS B AS SHOWN.
- 2) CONC. DESIGN STRENGTH 3000 PSI.
- 3) CHAMFER ALL EXPOSED EDGES 3/4".
- 4) 2" CLEARANCE ON ALL BARS.

PROFILE SHOWING BARS

CONC. ENDWALL FOR
MULTIPLE 60" - 78" ROUND
PIPES

**CITY OF
JACKSONVILLE
STANDARD**

N.T.S.

PLATE D-412

DATE DRAWN 1-26-79

REVISED DATE 11-21-24

PIPE SIZE	DIMENSIONS								NO. BARS REQ.		
	V	W	X	Y	Z	BAR	SIZE	LENGTH	2-PIPES	3-PIPES	4-PIPES
60"	13'-9"	8'-3"	1'-3"	2'-3"	7'-2"	A	6	4'-2"	54	66	78
						B	4	*	17	17	17
						C	6	9'-9"	29	31	34
						D	4	7'-10"	18	20	22
						E	6	2'-6"	8	12	16
						F	6	1'-6"	8	12	16
66"	14'-9"	9'-1"	1'-3"	2'-8"	7'-8"	A	6	4'-7"	58	71	84
						B	4	*	17	17	17
						C	6	10'-3"	31	34	37
						D	4	8'-4"	18	20	22
						E	6	2'-6"	8	12	16
						F	6	1'-6"	8	12	16
72"	15'-9"	9'-8"	1'-4"	3'-1"	8'-3"	A	6	5'-1"	62	77	92
						B	4	*	17	17	17
						C	6	10'-11"	33	36	39
						D	4	8'-11"	20	22	24
						E	6	2'-6"	8	12	16
						F	6	1'-6"	8	12	16
78"	16'-9"	10'-3"	1'-4"	3'-8"	8'-10"	A	6	5'-8"	66	81	96
						B	4	*	17	17	17
						C	6	11'-6"	35	38	41
						D	4	9'-6"	20	22	24
						E	6	2'-6"	8	12	16
						F	6	1'-6"	8	12	16

* WIDTH OF ENDWALL LESS 4"

ESTIMATED QUANTITIES						
PIPE SIZE	2-PIPES		3-PIPES		4-PIPES	
	CONC. CU. YD.	STEEL LB.	CONC. CU. YD.	STEEL LB.	CONC. CU. YD.	STEEL LB.
60"	14.24	1307	16.97	1555	19.69	1802
66"	16.43	1459	19.63	1733	22.83	2007
72"	18.88	1645	22.51	1955	26.15	2264
78"	21.62	1835	25.76	2167	29.90	2501

DIMENSIONAL AND QUANTITATIVE DATA FOR MULTIPLE 60"-78" CONC. PIPE ENDWALLS

CITY OF JACKSONVILLE STANDARD

N.T.S.

PLATE D-413

DATE DRAWN 2-17-79

REVISED DATE 11-21-24

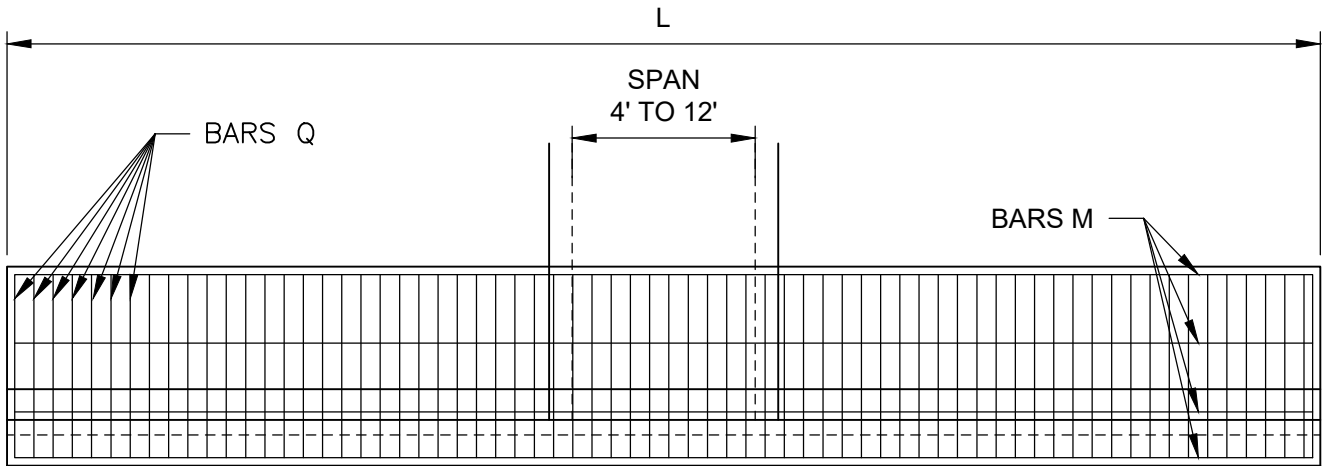

PLAN-SHOWING BARS IN FOOTING

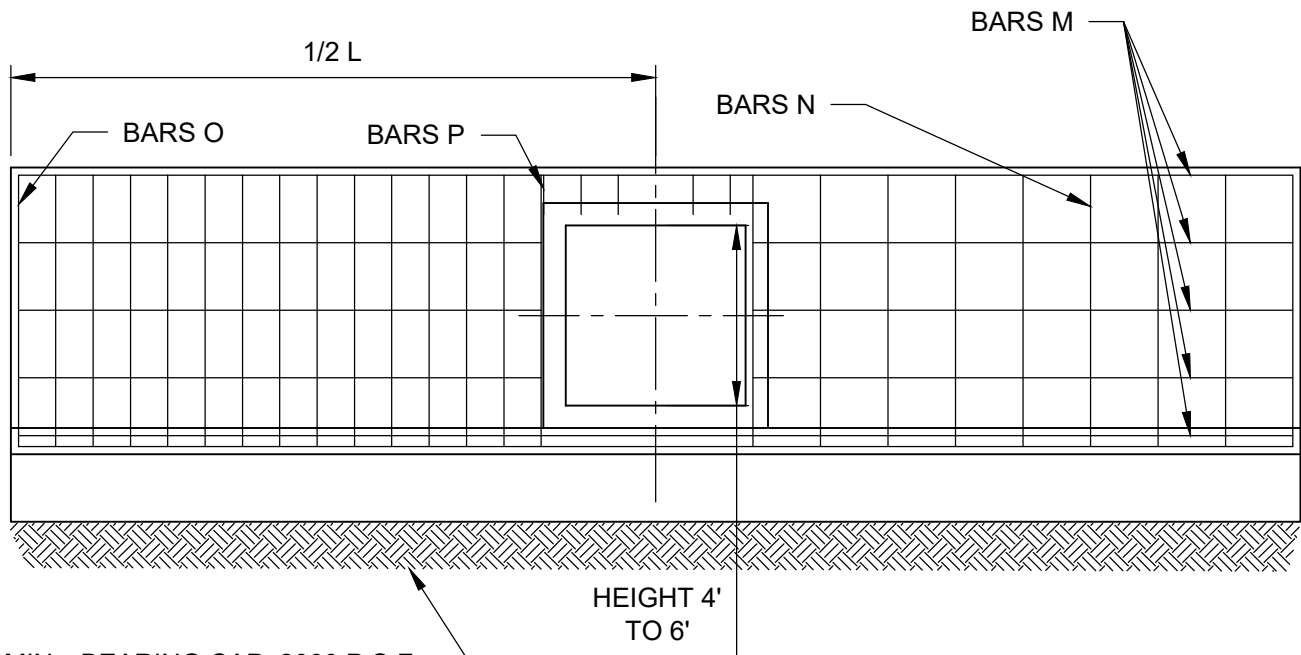

MIN. BEARING CAP. 2000 P.S.F.

HALF ELEV. SHOWING BARS
IN BACK FACE OF WALL

HALF ELEV. SHOWING BARS IN
FRONT FACE OF WALL

NOTES:

- 1) CONC. DESIGN STRENGTH 3400 P.S.I. (CLASS II F.D.O.T.)
- 2) CHAMFER ALL EXPOSED EDGES 3/4".
- 3) 2" CLEARANCE ON ALL BARS.
- 4) FIELD BEND BARS EXTENDING FROM PRECAST BOX CULVERT AND TIE TO ENDWALL STEEL.

STRAIGHT ENDWALL FOR
SINGLE PRECAST CONC. BOX
CULVERT

CITY OF
JACKSONVILLE
STANDARD

N.T.S.

PLATE D-414

DATE DRAWN 2-2-79

REVISED DATE 11-21-24

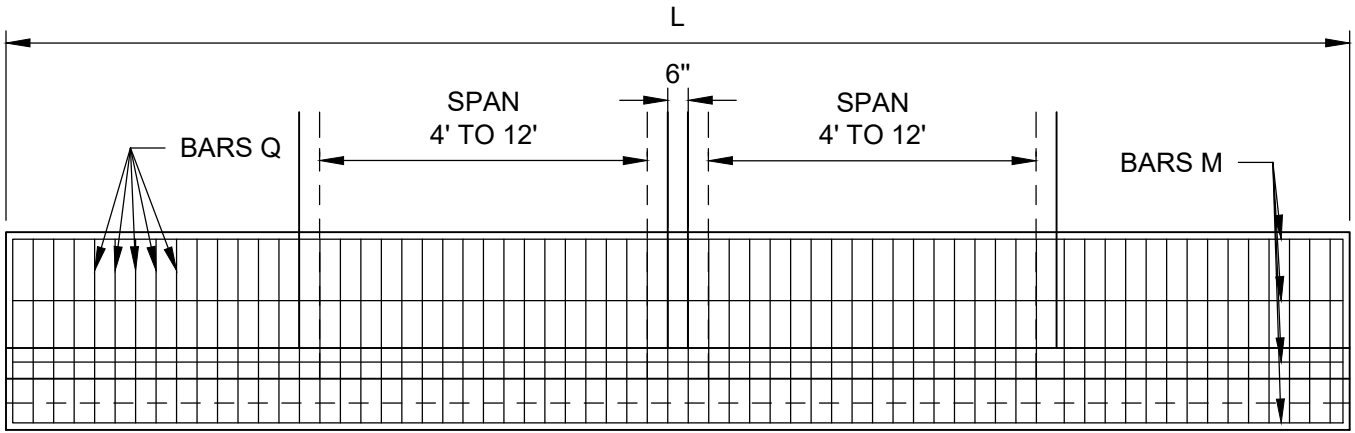

PLAN-SHOWING BARS IN FOOTING

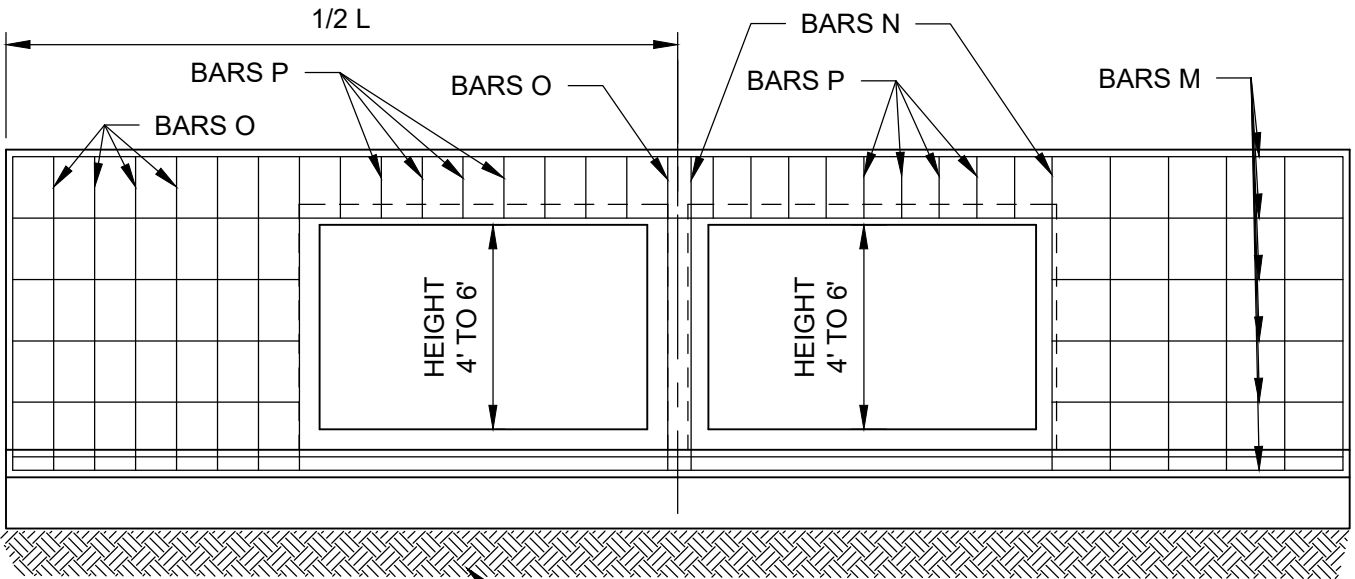

MIN. BEARING CAP. 2000 P.S.F.

**HALF ELEV. SHOWING BARS
IN BACK FACE OF WALL**

**HALF ELEV. SHOWING BARS IN
FRONT FACE OF WALL**

NOTES:

- 1) CONC. DESIGN STRENGTH 3400 P.S.I. (CLASS II F.D.O.T.)
- 2) CHAMFER ALL EXPOSED EDGES 3/4".
- 3) 2" CLEARANCE ON ALL BARS.
- 4) FIELD BEND BARS EXTENDING FROM PRECAST BOX CULVERT AND TIE TO ENDWALL STEEL.

STRAIGHT ENDWALL FOR
DOUBLE PRECAST CONC. BOX
CULVERT

CITY OF
JACKSONVILLE
STANDARD

N.T.S.

PLATE D-415

DATE DRAWN 2-2-79

REVISED DATE 11-21-24

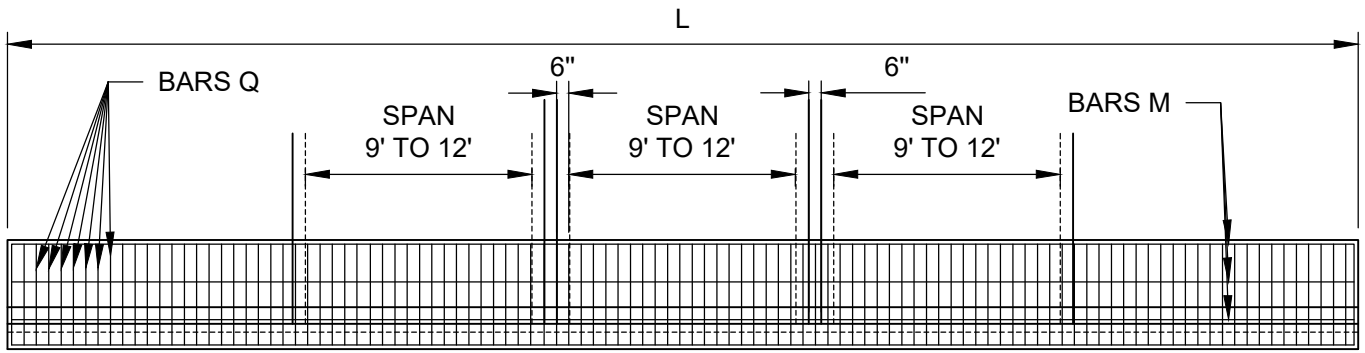

PLAN SHOWING BARS IN FOOTING

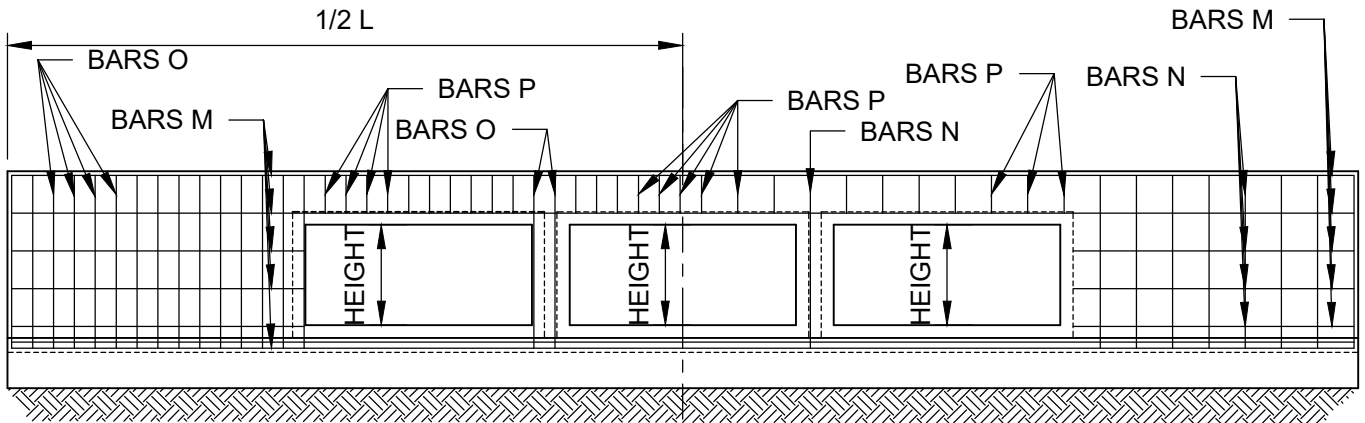

MIN. BEARING
CAP. 2000 P.S.F.

HALF ELEV. SHOWING BARS
IN BACK FACE OF WALL

HALF ELEV. SHOWING BARS
IN FRONT FACE OF WALL

NOTES:

- 1) CONC. DESIGN STRENGTH 3400 P.S.I. (CLASS II F.D.O.T.)
- 2) CHAMFER ALL EXPOSED EDGES 3/4".
- 3) 2" CLEARANCE ON ALL BARS.
- 4) FIELD BEND BARS EXTENDING FROM PRECAST BOX CULVERT AND TIE TO ENDWALL STEEL.

STRAIGHT ENDWALL FOR TRIPLE PRECAST CONC. BOX CULVERTS	CITY OF JACKSONVILLE STANDARD	N.T.S.	PLATE D-416
		DATE DRAWN 4-5-79	
		REVISED DATE 11-21-24	

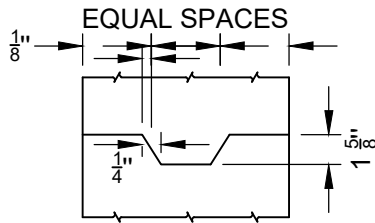

CONST. JOINT
DETAIL

NOTE: 10 BARS M
REQ. IN WALL
OVER 6'-1 1/2" HIGH
(H)

NOTE: CONC. CAP MAY BE
TRANSITIONED INTO CONC.
SPLASH PAD OR DITCH
PAVING.

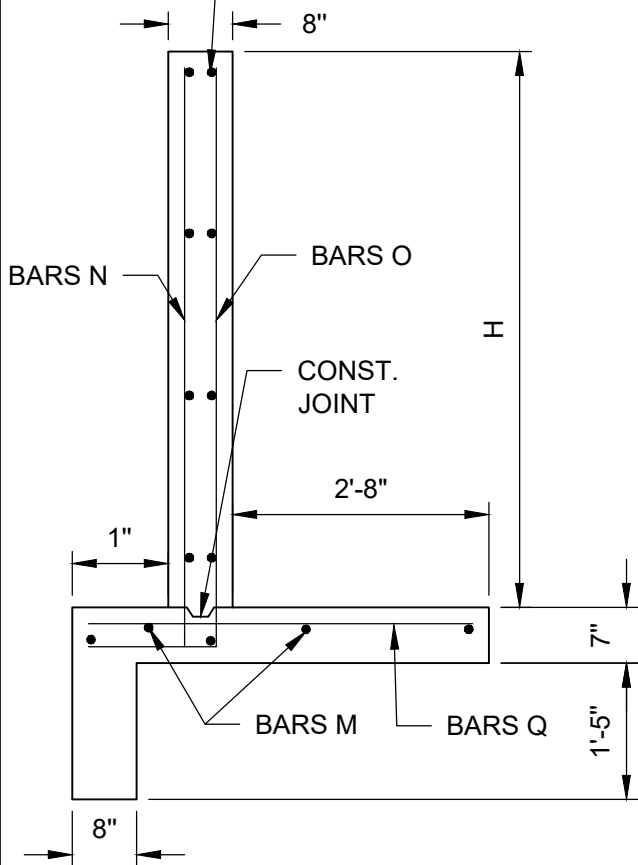

SECTION THRU
WING

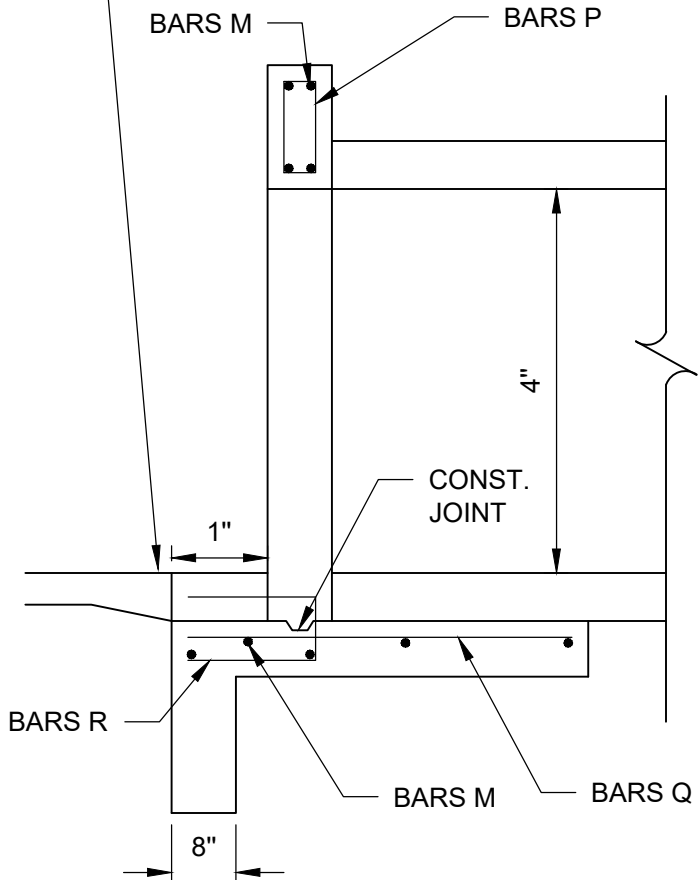

HALF SECTION
THRU BOX

SECTIONS OF ENDWALL FOR
4' HIGH SINGLE, DOUBLE, &
TRIPLE PRECAST CULVERTS

CITY OF
JACKSONVILLE
STANDARD

N.T.S.

PLATE D-417

DATE DRAWN 4-5-79

REVISED DATE 11-21-24

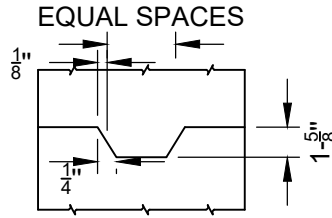

CONST. JOINT
DETAIL

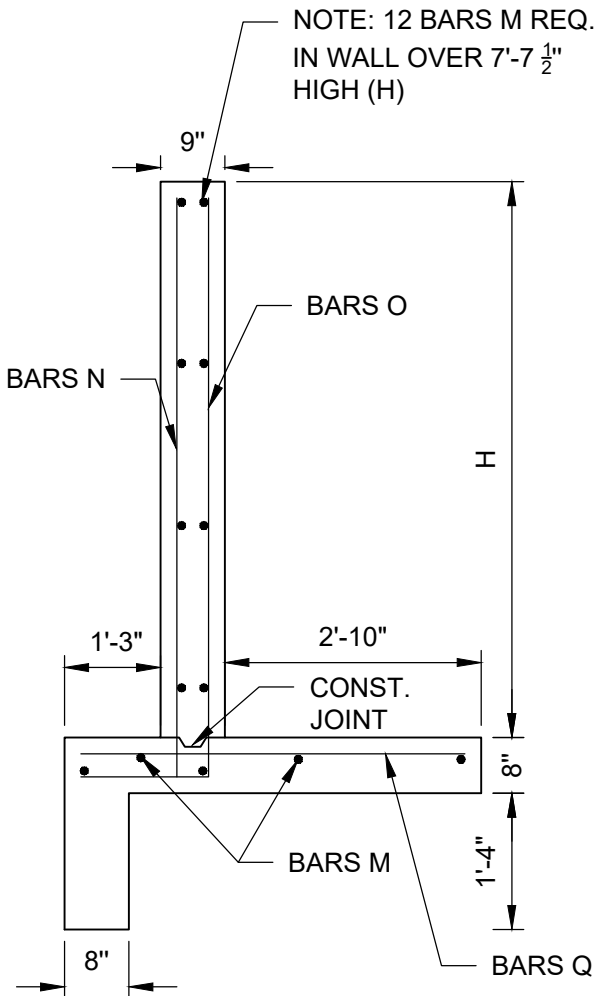

SECTION THRU WING

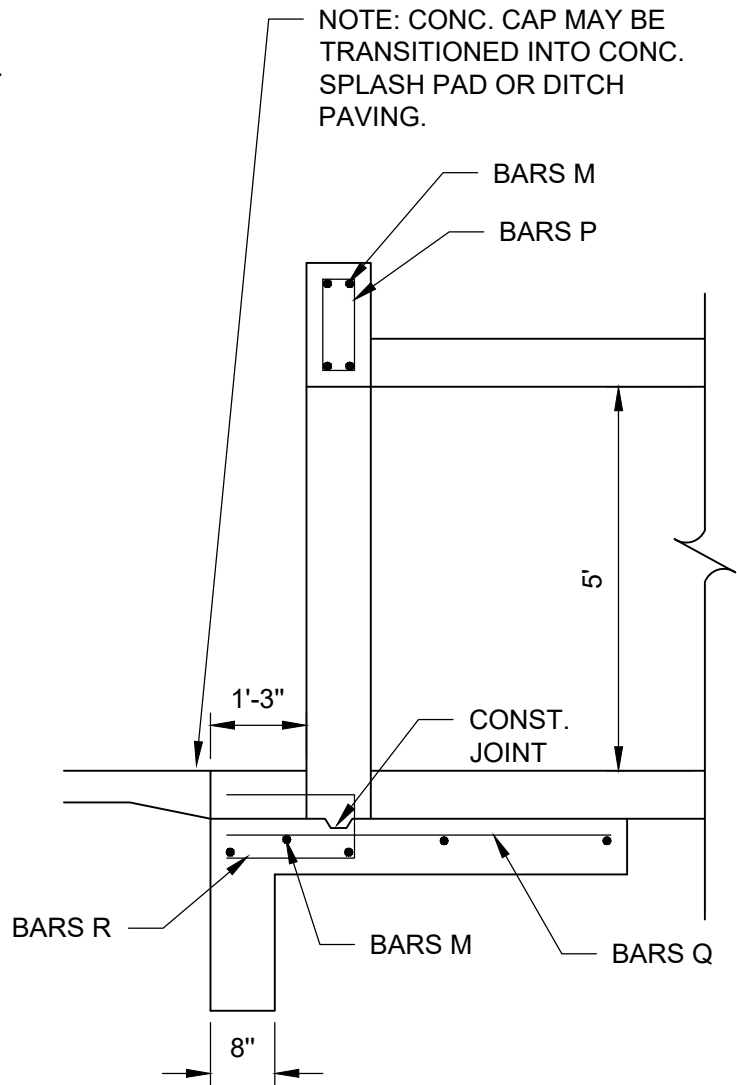

HALF SECTION
THRU BOX

SECTIONS OF ENDWALL FOR 5'
HIGH SINGLE, DOUBLE, & TRIPLE
PRECAST CULVERTS

CITY OF
JACKSONVILLE
STANDARD

N.T.S.

PLATE D-418

DATE DRAWN 2-27-79

REVISED DATE 11-21-24

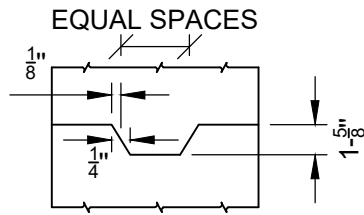

CONST. JOINT
DETAIL

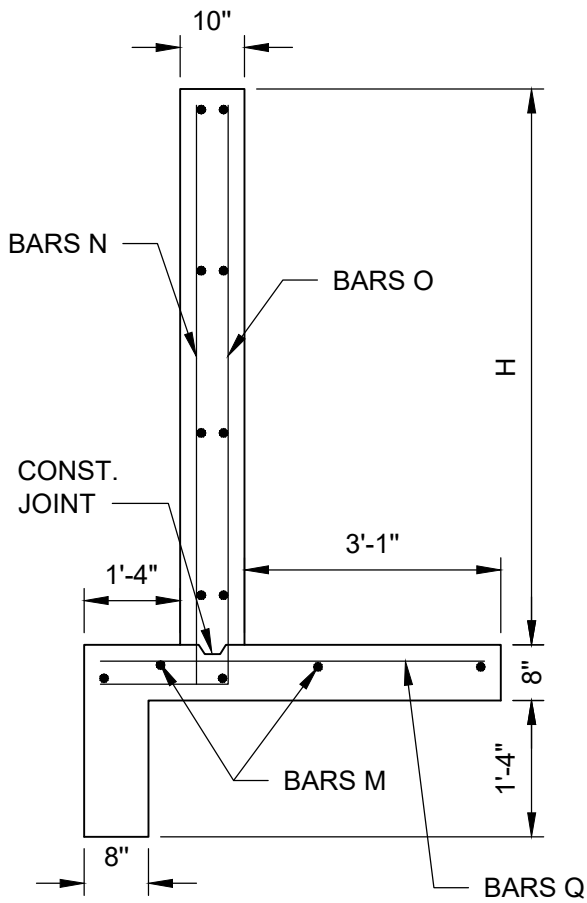

SECTION THRU WING

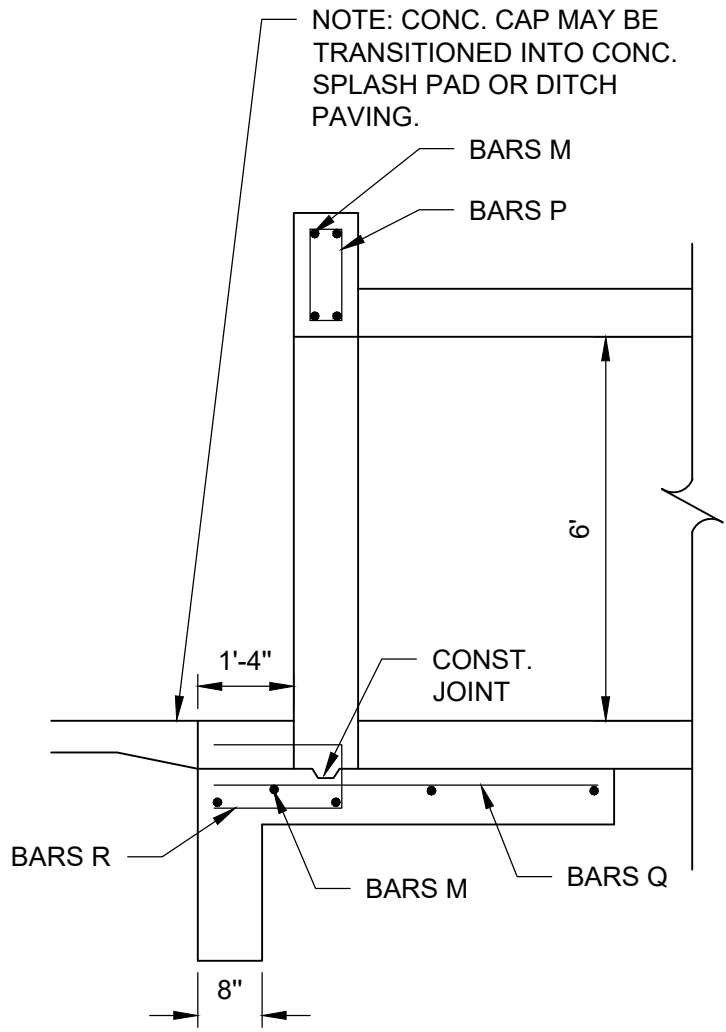

HALF SECTION
THRU BOX

SECTIONS OF ENDWALL FOR
6' HIGH SINGLE, DOUBLE, &
TRIPLE PRECAST CULVERTS

CITY OF
JACKSONVILLE
STANDARD

N.T.S.

PLATE D-419

DATE DRAWN 4-3-79

REVISED DATE 11-21-24

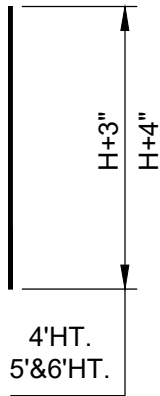

BARS N

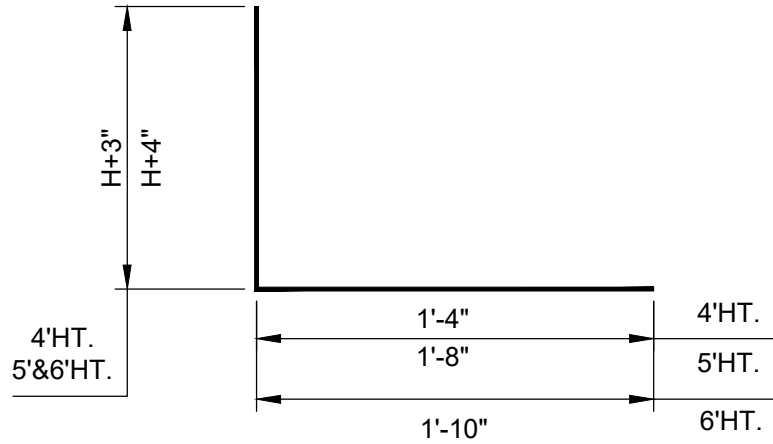

BARS O

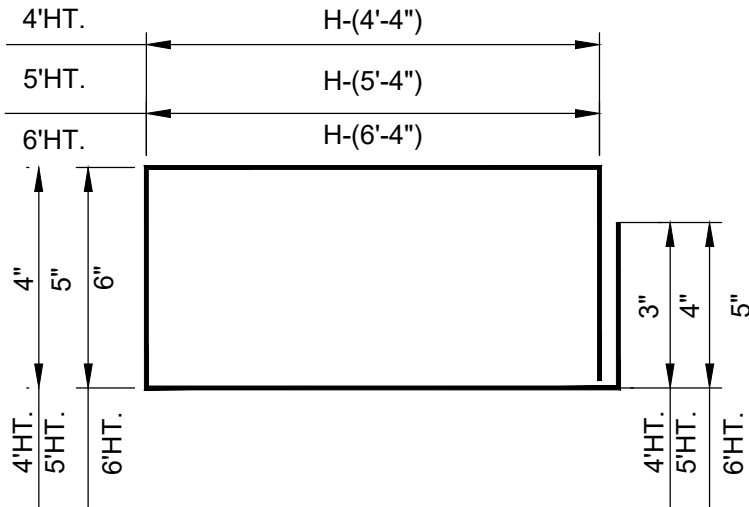

BARS P

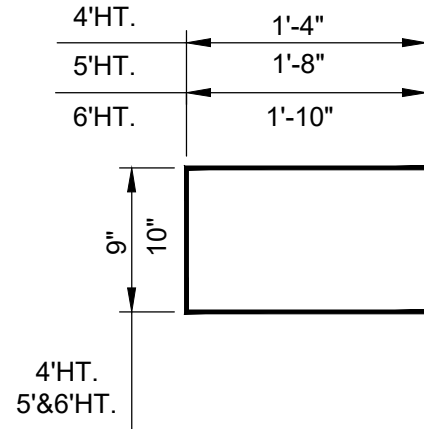

BARS R

NOTE: REINFORCING STEEL SHALL CONFORM TO CURRENT F.D.O.T. STANDARD SPECIFICATIONS FOR ROAD & BRIDGE CONSTRUCTION BARS M & Q ARE STRAIGHT BARS.

BAR BENDING DIAGRAM FOR
STEEL IN ENDWALL FOR
SINGLE, DOUBLE & TRIPLE
PRECAST BOX CULVERTS

CITY OF
JACKSONVILLE
STANDARD

N.T.S.

PLATE D-420

DATE DRAWN 2-5-79

REVISED DATE 11-21-24

DIMENSIONAL & QUANTITATIVE DATA

SPAN	CULVERT		MAX. FILL HEIGHT	L	H	CU. YDS.	BAR	SIZE	LENGTH	NO.	SPACE	BAR	SIZE	LENGTH	NO.	SPACE													
	HEIGHT	HEIGHT																											
4'-0"	4'-0"	6'-0"	28'-8"	5'-9 1/2"	7.34	M	4	6'-1"	13	18"	P	4	3'-11"	5	10"														
																5'-0"	31'-4"	6'-9 1/2"	10.07	N	4	7'-2"	20	17 3/4"	Q	5	4'-6"	46	8 1/2"
5'-0"	32'-4"	6'-10 1/4"	10.34	M	4	*	15	18"	P	5	4'-2 1/4"	5	12"																
														5'-0"	36'-2"	7'-10 1/4"	13.61	N	4	8'-2 1/4"	22	18"	Q	5	4'-11"	67	6 1/2"		
																												6'-0"	37'-0"
6'-0"	32'-0"	5'-11"	8.11	M	4	*	13	18"	P	4	4'-1"	7	10"																
														5'-0"	33'-4"	6'-11"	10.53	N	4	6'-2"	20	16 7/8"	Q	4	4'-0"	70	5 1/2"		
																												6'-0"	37'-0"
7'-0"	4'-0"	6'-0"	32'-10"	5'-11 1/2"	8.26	M	4	*	15	18"	P	5	4'-4"	6	12"														
																5'-0"	34'-4"	6'-11 1/2"	10.76	N	4	7'-3"	20	17 3/4"	Q	5	4'-6"	49	8 1/4"
5'-0"	34'-4"	6'-11 1/2"	10.76	M	4	*	15	18"	P	5	4'-5"	7	12"																
														6'-0"	37'-10"	7'-11 1/2"	13.98	N	4	7'-3 1/2"	20	17 3/4"	Q	5	4'-6"	49	8 1/2"		
5'-0"	34'-4"	6'-11 1/2"	10.76	O	5	8'-11 1/2"	28	12"	R	4	4'-0"	7	12"																
														6'-0"	37'-10"	7'-11 1/2"	13.98	M	4	*	17	18"	P	5	4'-8"	8	10"		
5'-0"	34'-4"	6'-11 1/2"	10.76	N	4	8'-3 1/2"	22	18"	Q	5	4'-11"	76	6"																
														6'-0"	37'-10"	7'-11 1/2"	13.98	O	5	10'-1 1/2"	38	10"	R	4	4'-4"	8	10"		

* WIDTH OF WALL LESS 4"

DIMENSIONAL & QUANTITATIVE DATA FOR SINGLE BOX CULVERT ENDWALLS

CITY OF JACKSONVILLE STANDARD

N.T.S.

PLATE D-421

DATE DRAWN 7-10-79

REVISED DATE 11-21-24

DIMENSIONAL AND QUANTITATIVE DATA

CULVERT		MAX. FILL HEIGHT	L	H	CU. YDS.	BAR	SIZE	LENGTH	NO.	SPACE	BAR	SIZE	LENGTH	NO.	SPACE
SPAN	HEIGHT														
8'-0"	4'-0"	5'-0"	33'-8"	6'-0"	8.41	M	4	*	13	18"	P	4	4'-3"	9	10"
	5'-0"	5'-0"	37'-4"	7'-0"	11.68	N	4	6'-3"	18	18"	Q	4	4'-0"	65	6 1/4"
	6'-0"	5'-0"	38'-8"	8'-0"	14.16	O	4	7'-7"	30	10"	R	4	3'-3"	9	10"
9'-0"	4'-0"	5'-0"	35'-4"	6'-1/2"	8.79	M	4	*	13	18"	P	4	4'-4"	11	10"
	5'-0"	5'-0"	38'-4"	7'-1/2"	11.91	N	4	6'-3 1/2"	20	17"	Q	4	4'-0"	71	6"
	6'-0"	5'-0"	40'-4"	8'-1/2"	14.49	O	4	7'-7 1/2"	32	10"	R	4	3'-3"	11	10"
10'-0"	4'-0"	5'-0"	36'-2"	6'-1 1/2"	8.97	M	4	*	13	18"	P	4	4'-6"	12	10"
	5'-0"	5'-0"	39'-4"	7'-1 1/2"	12.18	N	4	6'-4 1/2"	20	17"	Q	4	4'-0"	79	5 1/2"
	6'-0"	5'-0"	41'-2"	8'-1 1/2"	14.92	O	4	7'-8 1/2"	32	10"	R	4	3'-3"	12	10"
11'-0"	4'-0"	5'-0"	37'-0"	6'-2 1/2"	9.17	M	4	*	15	18"	P	5	4'-9"	10	12"
	5'-0"	5'-0"	40'-4"	7'-2 1/2"	12.47	N	4	7'-5 1/2"	22	17"	Q	5	4'-6"	79	6"
	6'-0"	5'-0"	43'-8"	8'-2 1/2"	15.86	O	4	9'-1 1/2"	30	12"	R	4	4'-0"	10	12"
	4'-0"	5'-0"	37'-0"	6'-2 1/2"	9.17	M	4	*	17	18"	P	5	5'-0"	12	10"
	5'-0"	5'-0"	40'-4"	7'-2 1/2"	12.47	N	4	8'-5 1/2"	22	18"	Q	5	4'-11"	78	6 3/8"
	6'-0"	5'-0"	43'-8"	8'-2 1/2"	15.86	O	4	10'-3 1/2"	38	10"	R	4	4'-4"	12	10"
	4'-0"	5'-0"	37'-0"	6'-2 1/2"	9.17	M	4	*	15	18"	P	4	4'-8"	13	10"
	5'-0"	5'-0"	40'-4"	7'-2 1/2"	12.47	N	4	6'-5 1/2"	20	16 3/8"	Q	4	4'-0"	76	5 7/8"
	6'-0"	5'-0"	43'-8"	8'-2 1/2"	15.86	O	4	7'-9 1/2"	32	10"	R	4	3'-3"	13	10"
	4'-0"	5'-0"	37'-0"	6'-2 1/2"	9.17	M	4	*	15	18"	P	5	4'-11"	11	12"
	5'-0"	5'-0"	40'-4"	7'-2 1/2"	12.47	N	4	7'-6 1/2"	22	17"	Q	5	4'-6"	6	8"
	6'-0"	5'-0"	43'-8"	8'-2 1/2"	15.86	O	4	9'-2 1/2"	30	12"	R	4	4'-0"	11	12"
	4'-0"	5'-0"	37'-0"	6'-2 1/2"	9.17	M	4	*	17	18"	P	5	5'-2"	13	10"
	5'-0"	5'-0"	40'-4"	7'-2 1/2"	12.47	N	4	8'-6 1/2"	24	17 3/8"	Q	5	4'-11"	81	6 1/2"
	6'-0"	5'-0"	43'-8"	8'-2 1/2"	15.86	O	4	10'-4 1/2"	40	10"	R	4	4'-4"	13	10"

* WIDTH OF WALL LESS 4"

DIMENSIONAL & QUANTITATIVE DATA FOR SINGLE BOX CULVERT ENDWALLS

CITY OF JACKSONVILLE STANDARD

N.T.S.

PLATE D-422

DATE DRAWN 9-9-79

REVISED DATE 11-21-24

DIMENSIONAL AND QUANTITATIVE DATA

CULVERT SPAN	CULVERT HEIGHT	MAX. FILL HEIGHT	L	H	CU. YDS.	BAR	SIZE	LENGTH	NO.	SPACE	BAR	SIZE	LENGTH	NO.	SPACE
4'-0"	4'-0"	6'-0"	32'-10"	6'-4"	8.35	M	4	*	15	18"	P	4	3'-11"	10	10"
						N	4	6'-7"	19	17"	Q	4	4'-0"	66	6"
						O	4	7'-11"	30	10"	R	4	3'-3"	10	10"
4'-0"	5'-0"	6'-0"	36'-1"	7'-4"	11.54	M	4	*	15	18"	P	5	4'-2"	8	11"
						N	4	7'-8"	21	17"	Q	5	4'-6"	53	8 1/2"
						O	5	9'-4"	32	12"	R	4	4'-0"	8	11"
4'-0"	6'-0"	6'-0"	37'-10"	8'-4"	14.17	M	4	*	17	18"	P	5	4'-5"	10	10"
						N	4	8'-8"	21	18"	Q	5	4'-11"	76	6"
						O	5	10'-6"	36	10"	R	4	4'-4"	10	10"
5'-0"	4'-0"	6'-0"	34'-6"	6'-4"	8.66	M	4	*	15	18"	P	4	3'-11"	12	10"
						N	4	6'-7"	19	16 3/4"	Q	4	4'-0"	74	5 5/8"
						O	4	7'-11"	30	10"	R	4	3'-3"	12	10"
5'-0"	5'-0"	6'-0"	37'-11"	7'-4"	11.88	M	4	*	15	18"	P	5	4'-2"	10	11"
						N	4	7'-8"	21	17"	Q	5	4'-6"	54	8 1/2"
						O	5	9'-4"	32	11"	R	4	4'-0"	10	11"
6'-0"	6'-0"	6'-0"	41'-2"	8'-4"	15.14	M	4	*	17	18"	P	5	4'-5"	12	10"
						N	4	8'-8"	21	17 1/2"	Q	5	4'-11"	61	6 1/2"
						O	5	10'-6"	38	10"	R	4	4'-4"	12	10"
6'-0"	4'-0"	6'-0"	37'-10"	6'-4"	9.38	M	4	*	15	18"	P	4	3'-11"	14	10"
						N	4	6'-7"	19	17 1/2"	Q	4	4'-0"	76	6"
						O	4	7'-11"	30	10"	R	4	3'-3"	14	10"
6'-0"	5'-0"	6'-0"	39'-6"	7'-4"	12.13	M	4	*	15	18"	P	5	4'-2"	14	10"
						N	4	7'-8"	21	17"	Q	5	4'-6"	58	8 1/4"
						O	5	9'-4"	34	10"	R	4	4'-0"	14	10"
7'-0"	6'-0"	6'-0"	42'-10"	8'-4"	15.42	M	4	*	17	18"	P	5	4'-5"	14	10"
						N	4	8'-8"	23	17"	Q	5	4'-11"	86	6"
						O	5	10'-6"	38	10"	R	4	4'-4"	14	10"
7'-0"	4'-0"	5'-0"	39'-6"	6'-4"	9.63	M	4	*	15	18"	P	4	3'-11"	16	10"
						N	4	6'-7"	19	17 1/2"	Q	4	4'-0"	81	5 7/8"
						O	4	7'-11"	32	10"	R	4	3'-3"	16	10"
7'-0"	5'-0"	5'-0"	42'-10"	7'-4"	12.98	M	4	*	15	18"	P	5	4'-2"	16	10"
						N	4	7'-8"	21	17 1/2"	Q	5	4'-6"	61	8 1/2"
						O	5	9'-4"	36	10"	R	4	4'-0"	16	10"
7'-0"	6'-0"	5'-0"	44'-6"	8'-4"	15.69	M	4	*	17	18"	P	5	4'-5"	16	10"
						N	4	8'-8"	23	17"	Q	5	4'-11"	84	6 3/8"
						O	5	10'-6"	38	10"	R	4	4'-4"	16	10"

* WIDTH OF WALL LESS 4"

DIMENSIONAL & QUANTITATIVE DATA FOR DOUBLE BOX CULVERT ENDWALLS

CITY OF JACKSONVILLE STANDARD

N.T.S.	PLATE D-424
DATE DRAWN	7-5-79
REVISED DATE	11-21-24

DIMENSIONAL AND QUANTITATIVE DATA

CULVERT		MAX. FILL HEIGHT	L	H	CU. YDS.	BAR	SIZE	LENGTH	NO.	SPACE	BAR	SIZE	LENGTH	NO.	SPACE	NO.	LENGTH	NO.	SPACE
SPAN	HEIGHT																		
8'-0"	4'-0"	5'-0"	42'-1/2"	6'-5 1/2"	10.32	M	4	*	15	18"	P	4	4'-2"	20	9 1/2"	20	4'-2"	20	9 1/2"
	5'-0"	5'-0"	45'-5 1/2"	7'-5 1/2"	13.75	N	4	6'-8 1/2"	19	18"	Q	4	4'-0"	98	5 3/16"	98	4'-0"	98	5 3/16"
	6'-0"	5'-0"	48'-7 1/2"	8'-5 1/2"	17.19	O	4	8'-1/2"	31	9 1/2"	R	4	3'-3"	20	10"	20	3'-3"	20	10"
9'-0"	4'-0"	5'-0"	43'-1"	6'-5 1/2"	10.32	M	4	*	15	18"	P	4	4'-2"	24	9"	24	4'-2"	24	9"
	5'-0"	5'-0"	46'-10"	7'-5 1/2"	13.92	N	4	6'-8 1/2"	19	17"	Q	4	4'-0"	90	5 3/4"	90	4'-0"	90	5 3/4"
	6'-0"	5'-0"	49'-1"	8'-5 1/2"	16.96	O	4	8'-1/2"	34	9"	R	4	3'-3"	24	9"	24	3'-3"	24	9"
10'-0"	4'-0"	5'-0"	46'-2"	6'-7 1/2"	11.14	M	4	*	15	18"	P	4	4'-5 1/2"	24	10"	24	4'-5 1/2"	24	10"
	5'-0"	5'-0"	49'-4"	7'-7 1/4"	14.70	N	4	6'-10 1/4"	19	18"	Q	4	4'-0"	101	5 1/2"	101	4'-0"	101	5 1/2"
	6'-0"	5'-0"	52'-10"	8'-7 1/4"	18.36	O	4	8'-2 1/4"	32	10"	R	4	3'-3"	24	10"	24	3'-3"	24	10"
11'-0"	4'-0"	5'-0"	47'-10"	6'-7 1/4"	11.39	M	4	*	15	18"	P	4	4'-8 1/2"	22	12"	22	4'-8 1/2"	22	12"
	5'-0"	5'-0"	51'-4"	7'-7 1/4"	15.21	N	4	7'-11 1/4"	21	18"	Q	4	4'-6"	70	8 1/2"	70	4'-6"	70	8 1/2"
	6'-0"	5'-0"	54'-2"	8'-7 1/4"	18.51	O	4	10'-9 1/4"	40	10"	R	4	4'-4"	24	10"	24	4'-4"	24	10"

* WIDTH OF WALL LESS 4"

DIMENSIONAL & QUANTITATIVE DATA FOR DOUBLE BOX CULVERT ENDWALLS

CITY OF JACKSONVILLE STANDARD

N.T.S.

PLATE D-425

DATE DRAWN 7-5-79

REVISED DATE 11-21-24

DIMENSIONAL AND QUANTITATIVE DATA

CULVERT SPAN	HEIGHT	MAX. FILL HEIGHT	L	H	CU. YDS.	BAR	SIZE	LENGTH	NO.	SPACE	BAR	SIZE	LENGTH	NO.	SPACE							
																NO.	SPACE					
12'-0"	4'-0"	5'-0"	51'-2"	6'-9"	12.31	M	4	*	15	18"	P	4	4'-9"	28	10"							
						N	4	7'-0"	21	16 1/2"	Q	4	4'-0"	107	5 3/4"							
						O	4	8'-4"	34	10"	R	4	3'-3"	28	10"							
						M	4	*	17	18"	P	5	5'-0"	24	11 1/2"							
						N	4	8'-1"	21	17 3/4"	Q	5	4'-6"	80	8"							
						O	5	9'-9"	32	11 1/2"	R	4	4'-0"	24	11 1/2"							
	5'-0"	6'-0"	5'-0"	56'-2"	8'-9"	19.19	M	4	*	17	18"	P	5	5'-3"	28	10"						
							N	4	9'-1"	23	18"	Q	5	4'-11"	104	6 1/2"						
							O	5	10'-11"	40	10"	R	4	4'-4"	28	10"						

* WIDTH OF WALL LESS 4"

DIMENSIONAL & QUANTITATIVE
DATA FOR DOUBLE BOX
CULVERT ENDWALLS

CITY OF
JACKSONVILLE
STANDARD

N.T.S.	PLATE D-426
DATE DRAWN	7-5-79
REVISED DATE	11-21-24

DIMENSIONAL & QUANTITATIVE DATA

CULVERT SPAN	CULVERT HEIGHT	MAX. FILL HEIGHT	L	H	CU. YDS.	BAR	SIZE	LENGTH	NO.	SPACE	BAR	SIZE	LENGTH	NO.	SPACE
9'-0"	4'-0"	5'-0"	53'-8"	6'-7 1/2"	12.50	M	4	*	15	18"	P	4	4'-6"	33	10"
						N	4	6'-10 1/2"	20	18 1/4"	Q	4	4'-0"	110	5 7/8"
	O	4	8'-2 1/2"	32	10"	R	4	3'-3"	33	10"					
	M	4	*	15	18"	P	5	4'-9"	27	11 1/2"					
9'-0"	5'-0"	5'-0"	55'-11"	7'-7 1/2"	15.97	N	4	7'-11 1/2"	22	16 1/2"	Q	5	4'-6"	83	8 1/8"
						O	5	9'-7 1/2"	32	11 1/2"	R	4	4'-0"	27	11 1/2"
	M	4	*	17	18"	P	5	5'-0"	33	10"					
	N	4	8'-11 1/2"	24	16 1/2"	Q	5	4'-11"	113	6 1/4"					
9'-0"	6'-0"	5'-0"	58'-8"	8'-7 1/2"	20.22	O	5	10'-9 1/2"	38	10"	R	4	4'-4"	33	10"
						M	4	*	15	18"	P	4	4'-7 1/2"	36	10"
	N	4	6'-11 1/4"	20	16 3/4"	Q	4	4'-0"	115	5 7/8"					
	O	4	8'-3 1/4"	32	10"	R	4	3'-3"	36	10"					
10'-0"	4'-0"	5'-0"	56'-2"	6'-8 1/4"	12.98	M	4	*	17	18"	P	5	4'-10 1/2"	30	11 1/2"
						N	4	8'-1 1/4"	20	18"	Q	5	4'-6"	109	6 1/2"
	O	5	9'-8 1/4"	32	11 1/2"	R	4	4'-0"	30	11 1/2"					
	M	4	*	17	18"	P	5	5'-1 1/2"	36	10"					
10'-0"	5'-0"	5'-0"	58'-9 1/2"	7'-8 1/4"	16.62	N	4	9'-1 1/4"	24	17 1/2"	Q	5	4'-11"	121	6 1/4"
						O	5	10'-10 1/4"	40	10"	R	4	4'-4"	36	10"
	M	4	*	15	18"	P	4	4'-9"	39	10"					
	N	4	7'-0"	20	17 3/4"	Q	4	4'-0"	121	6"					
11'-0"	4'-0"	5'-0"	60'-4"	6'-9"	13.95	O	4	8'-4"	34	10"	R	4	3'-3"	39	10"
						M	4	*	17	18"	P	5	5'-0"	38	10 1/2"
	N	4	8'-1"	22	17"	Q	5	4'-6"	90	8 3/8"					
	O	5	9'-9"	34	10 1/2"	R	4	4'-0"	38	10 1/2"					
11'-0"	5'-0"	5'-0"	62'-5 1/2"	7'-9"	17.60	M	4	*	17	18"	P	5	5'-3"	39	10"
						N	4	9'-1"	24	17"	Q	5	4'-11"	121	6 1/2"
	O	5	10'-11"	40	10"	R	4	4'-4"	39	10"					
	M	4	*	15	18"	P	4	4'-11"	44	10"					
12'-0"	4'-0"	5'-0"	62'-10"	6'-10"	14.46	N	4	7'-1"	20	17"	Q	4	4'-0"	126	6"
						O	4	8'-5"	32	10"	R	4	3'-3"	44	10"
	M	4	*	17	18"	P	5	5'-2"	39	11"					
	N	4	8'-2"	22	17 3/4"	Q	5	4'-6"	100	8"					
12'-0"	5'-0"	5'-0"	66'-4"	7'-10"	18.69	O	5	9'-10"	34	11"	R	4	4'-0"	39	11"
						M	4	*	17	18"	P	5	5'-5"	44	10"
	N	4	9'-2"	24	17 7/8"	Q	5	4'-11"	100	8 3/8"					
	O	5	11'-0"	40	10"	R	4	4'-4"	44	10"					

* WIDTH OF WALL LESS 4"

DIMENSIONAL & QUANTITATIVE
DATA FOR TRIPLE BOX
CULVERT ENDWALLS

CITY OF
JACKSONVILLE
STANDARD

N.T.S.

PLATE D-427

DATE DRAWN

7-5-79

REVISED DATE

11-21-24

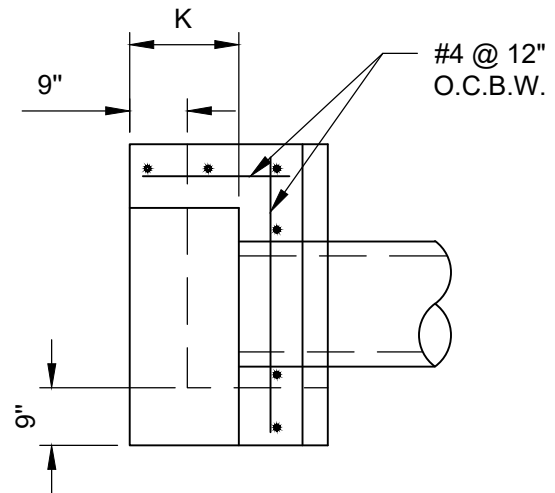
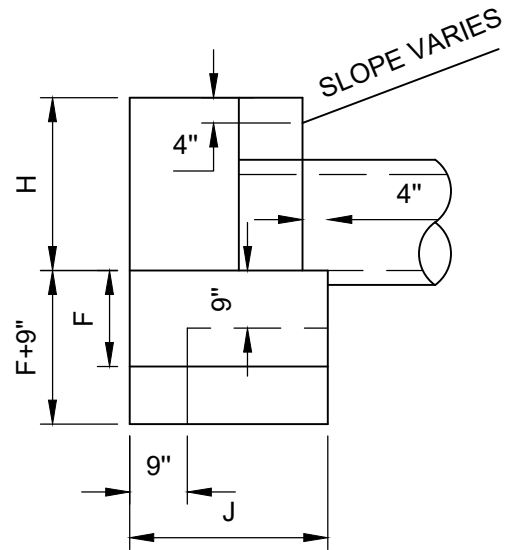
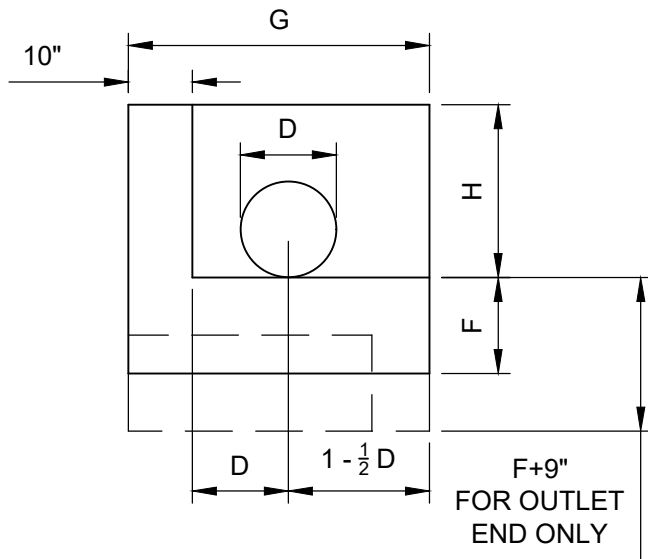

NOTES:

1. CHAMFER ALL EXPOSED EDGES 3/4".
2. MIN. BEARING CAPACITY 3000 P.S.I.
3. ALL REINF. STEEL TO BE CENTERED.
4. COST OF REINF. STEEL SHALL BE INCLUDED IN THE UNIT BID PRICE FOR "L" TYPE ENDWALL.

TABLE OF DIMENSIONS & ESTIMATED QUANTITIES PIPE CULVERT ENDWALLS WITH L-TYPE WINGS

OPENING		WALL			FOOTING		TOTAL CU. YDS. CONC. 3000 P.S.I.			
D	AREA SQ. FT.	G	H	K	F	J	CONC. PIPE		C.M. PIPE	
							INLET	OUTLET	INLET	OUTLET
15"	1.2	3'-11"	2'-3"	1'-5"	1'-3"	2'-7"	.68	0.8	0.7	0.82
18"	1.8	4'-7"	2'-6"	1'-9"	1'-3"	2'-11"	.86	1.0	0.89	1.03
24"	3.1	5'-10"	3'-0"	2'-6"	1'-6"	3'-8"	1.39	1.58	1.45	1.63
30"	4.9	7'-1"	3'-6"	3'-3"	1'-6"	4'-5"	1.98	2.2	2.05	2.28
36"	7.1	8'-4"	4'-0"	4'-0"	1'-9"	5'-2"	2.74	3.01	2.85	3.11
42"	9.6	9'-7"	4'-6"	4'-9"	2'-0"	5'-11"	3.63	3.94	3.77	4.08
48"	12.6	10'-10"	5'-0"	5'-6"	2'-0"	6'-8"	4.75	5.1	4.93	5.28

CONCRETE ENDWALL WITH
L-TYPE WING FOR PIPE
CULVERTS

**CITY OF
JACKSONVILLE
STANDARD**

N.T.S.

PLATE D-428

DATE DRAWN 5-12-94

REVISED DATE 11-21-24

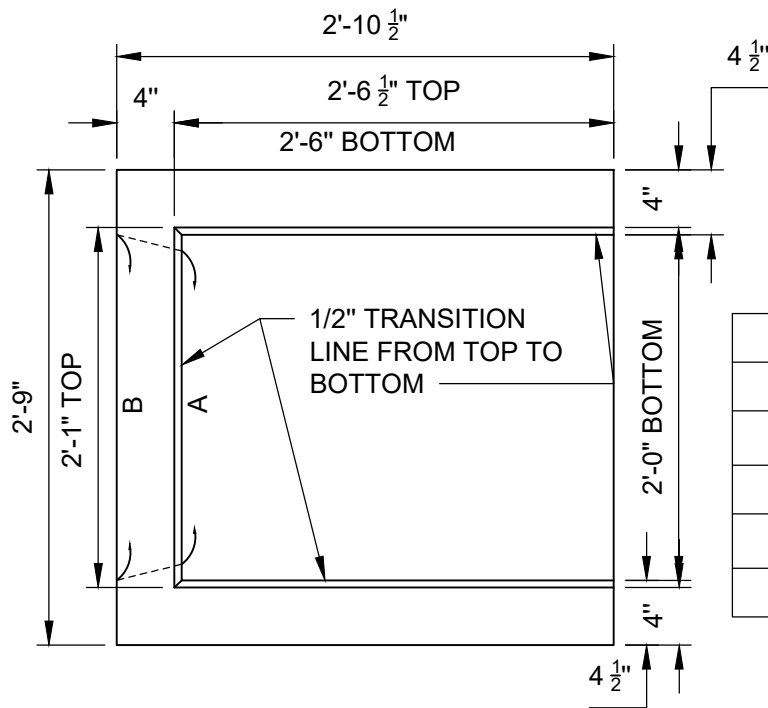
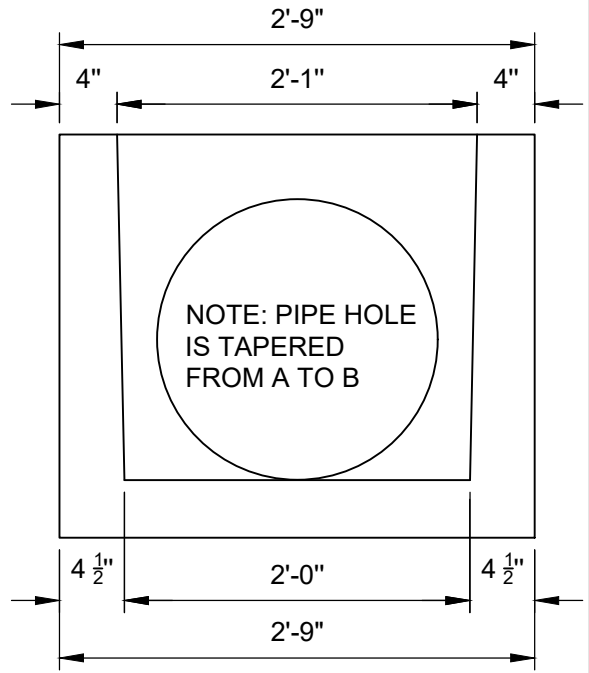
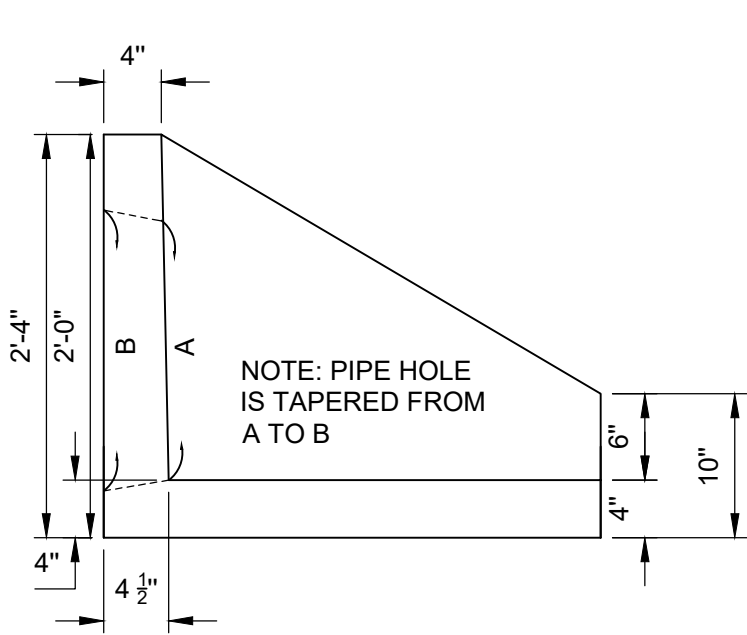

	A	B
15" RCP	20"	21"
15" CMP	15 1/2"	17"
18" RCP	25"	26"
18" CMP	18"	19 1/2"
24" CMP	25"	26"

SPECIFICATIONS:

1. BASE SLAB #4 BARS @ 9" O.C.E.W. WALLS #4 BARS @ 9" O.C.E.W.
2. 4,000 P.S.I. CONCRETE

PRECAST MITERED END
FOR DRIVEWAY CULVERTS

CITY OF
JACKSONVILLE
STANDARD

N.T.S.

PLATE D-429

DATE DRAWN 7-12-79

REVISED DATE 11-21-24

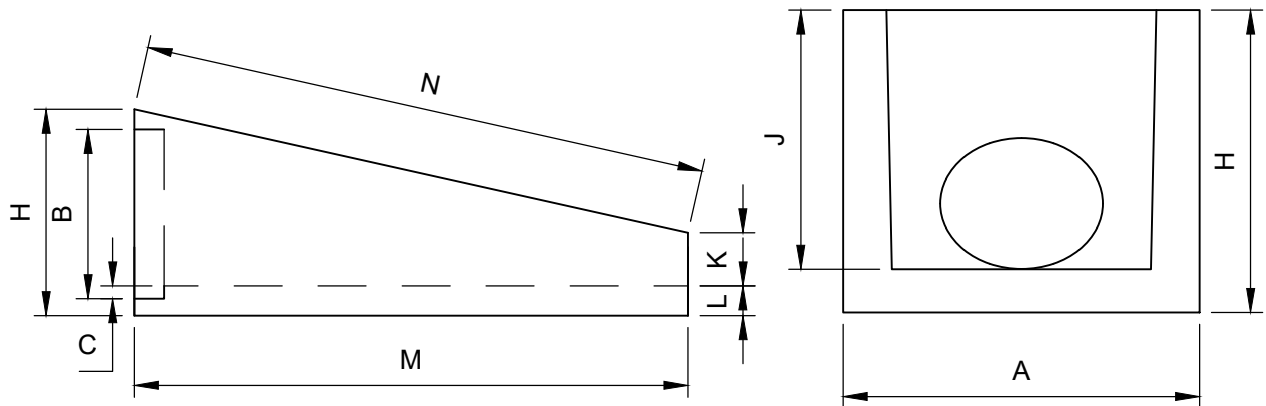

SIDE VIEW

END VIEW

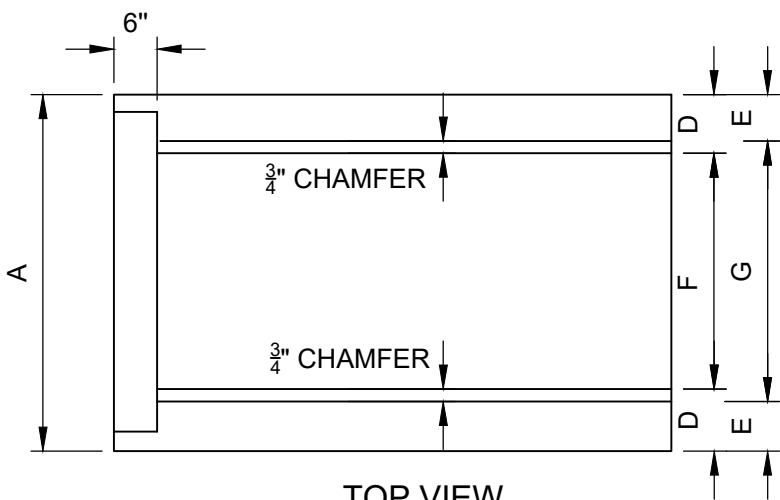

TOP VIEW

SPECIFICATIONS:

1. STEEL - #4 @ 12" E.W., WITH 1 #6 OVER PIPE OPENING. (1-1/2" OF CONCRETE COVER OVER STEEL, 1/2" TOLERANCE.)
2. 4,000 P.S.I. CONCRETE

ERCPC	CMPA	A	B	C	D	E	F	G	H	J	K	L	M	N
12" x 18"	13" x 17"	2'-7"	18 x 24	2 1/2"	6 1/2"	6"	1'-6"	1'-7"	2'-4"	1'-10"	8"	6"	4'-8"	4'-9 3/4"
14" x 23"	15" x 21"	3'-0"	21 x 30	2 3/4"	6 1/2"	6"	1'-11"	2'-0"	2'-7"	2'-1"	8"	6"	5'-8"	5'-10 1/4"
19" x 30"	20" x 28"	3'-8"	27 x 38	3 1/4"	6 1/2"	6"	2'-7"	2'-8"	3'-0"	2'-6"	8"	6"	7'-4"	7'-6 3/4"

PRECAST MITERED END FOR
ELLIPTICAL DRIVEWAY
CULVERTS

CITY OF
JACKSONVILLE
STANDARD

N.T.S.

PLATE D-430

DATE DRAWN 07-12-79

REVISED DATE 11-21-24

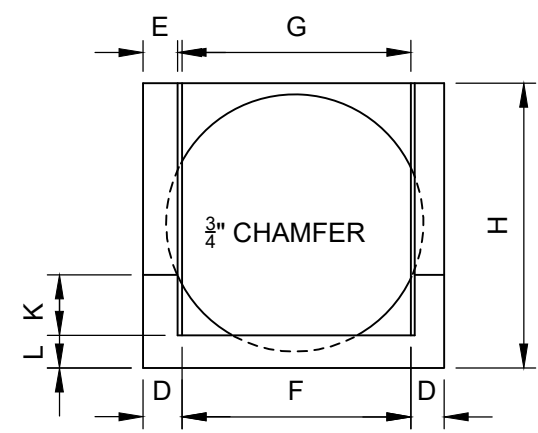
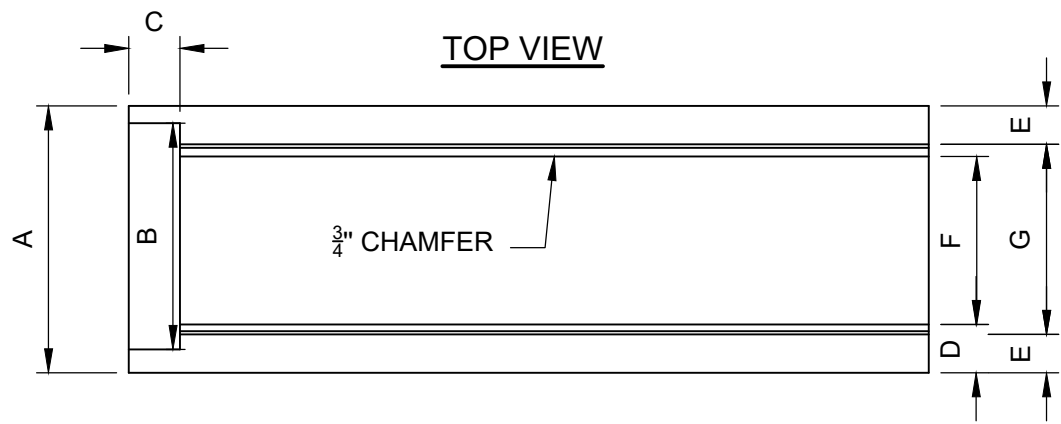
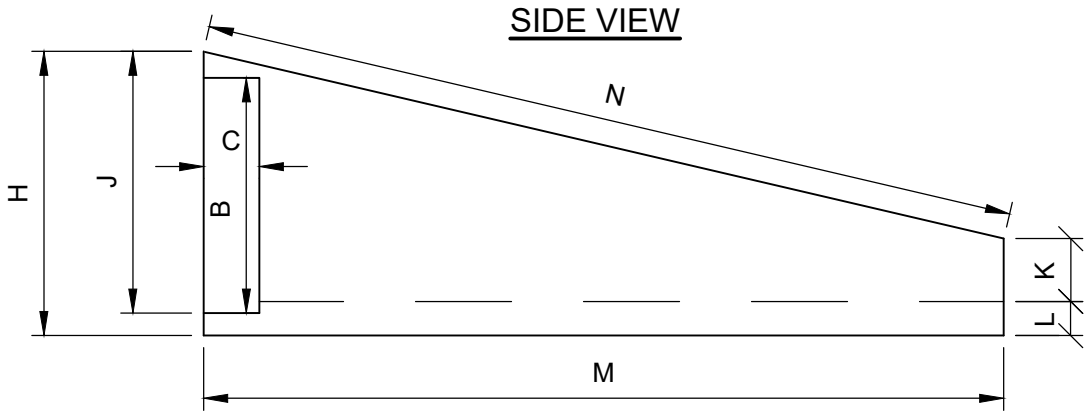

CONCRETE: 4,000 P.S.I.

STEEL: #4 @ 12" E.W., WITH 1 #6 OVER PIPE
 OPENING. (2" CLEARANCE OVER STEEL,
 REINF. BARS, 1/2" TOLERANCE).

END VIEW

STANDARD MITERED END SECTION FOR RCP OR CMP	CITY OF JACKSONVILLE STANDARD	N.T.S.	PLATE D-431
		DATE DRAWN	12-16-79
		REVISED DATE	11-21-24

TABLE OF DIMENSIONS

RCP/CMP	A	B	C	D	E	F	G
15" - 18"	2'-7"	2'-1"	6"	6"	6 3/4"	1'-6"	1'-7"
24"	2'-11"	2'-8"	6"	5"	4 1/2"	1'-11"	2'-0"
30"	3'-6"	3'-2"	6"	6"	5 1/2"	2'-5"	2'-6 1/2"
36"	4'-1"	3'-10"	6"	7"	5 1/2"	2'-9"	3'-0"

TABLE OF DIMENSIONS

RCP/CMP	H	J	K	L	M	N
15" - 18"	2'-10"	2'-4"	8"	6"	6'-10"	7'-0"
24"	3'-6"	3'-1"	7 1/2"	5"	10'-0"	10'-3 1/2"
30"	3'-9"	3'-5"	7"	5"	11'-5"	11'-8 1/4"
36"	4'-6"	4'-0"	6"	6"	14'-0"	14'-4 1/2"

STANDARD TABLE OF
DIMENSIONS FOR
MITERED END SECTION

CITY OF
JACKSONVILLE
STANDARD

N.T.S.

PLATE D-432

DATE DRAWN 8-9-79

REVISED DATE 11-21-24

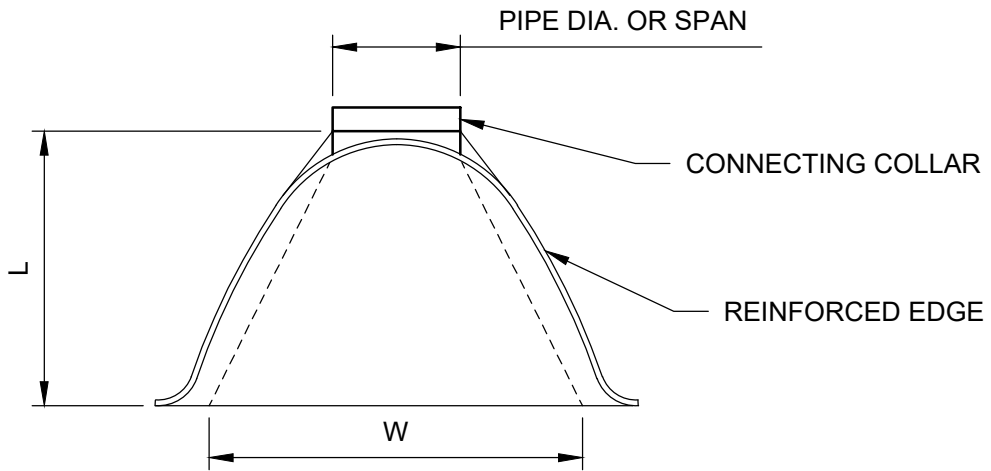

PLAN VIEW

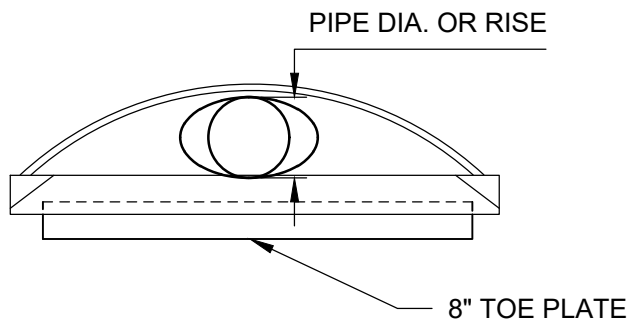

FRONT VIEW

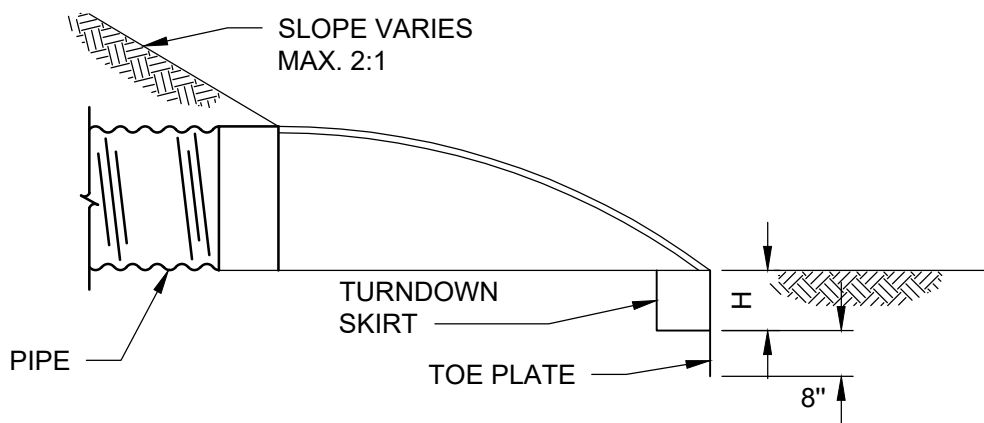

CROSS SECTION

FOR DIMENSIONAL DATA
SEE PLATE D-434

STANDARD FLARED END
SECTIONS FOR CORRUGATED
METAL PIPE

CITY OF
JACKSONVILLE
STANDARD

N.T.S.

PLATE D-433

DATE DRAWN 12-17-79

REVISED DATE 11-21-24

DIMENSIONS OF FLARED END SECTION FOR CIRCULAR CORRUGATED METAL PIPE

PIPE DIA	GAUGE	H (IN.)	L* (IN.)	W* (IN.)
15	16	6	26 1/4	30
18	16	6	31 1/2	36
21	16	6	36 3/4	42
24	14	6	42	48
30	14	7 1/2	52 1/2	60
36	12	9	63	72
42	12	10 1/2	73 1/2	84
48	12	12	84	96
54	12	12	94 1/2	109

* L = 1.75 x DIA.

* W = 2 x DIA.

DIMENSIONS OF FLARED END SECTION FOR ARCHED CORRUGATED METAL PIPE

SPAN (IN.)	RISE (IN.)	GAUGE	H (IN.)	L±2 (IN.)	MAX WIDTH (IN.)
17	13	16	6	20	52
21	15	16	6	24	58
24	18	16	6	28	63
28	20	14	6	32	70
35	24	14	6	39	85
42	29	12	6 3/4	46	104
49	33	12	7 3/4	53	117
57	38	12	9	62	132
64	43	12	10	69	144

NOTES:

1. END SECTION TO BE CONSTRUCTED OF SAME MATERIAL AS CONNECTING PIPE.
2. APPROVED RIGID, VANDAL-PROOF CONNECTORS SHALL BE USED TO CONNECT THE END SECTION TO PIPE.
3. DIMENSIONS L AND W MAY VARY BY 10% ±.
4. STANDARD 8" TOE PLATES SHALL BE ATTACHED TO ALL END SECTIONS BY SHOP RIVETING OR BY GALVANIZED BOLTS.
5. TOE PLATE AND CONNECTOR SECTION TO BE CONSTRUCTED OF SAME GAUGE MATERIAL AS END SECTION.

FLARED END SECTIONS
DIMENSIONAL DATA FOR
CORRUGATED METAL PIPE

**CITY OF
JACKSONVILLE
STANDARD**

N.T.S.

PLATE D-434

DATE DRAWN 12-20-79

REVISED DATE 11-21-24

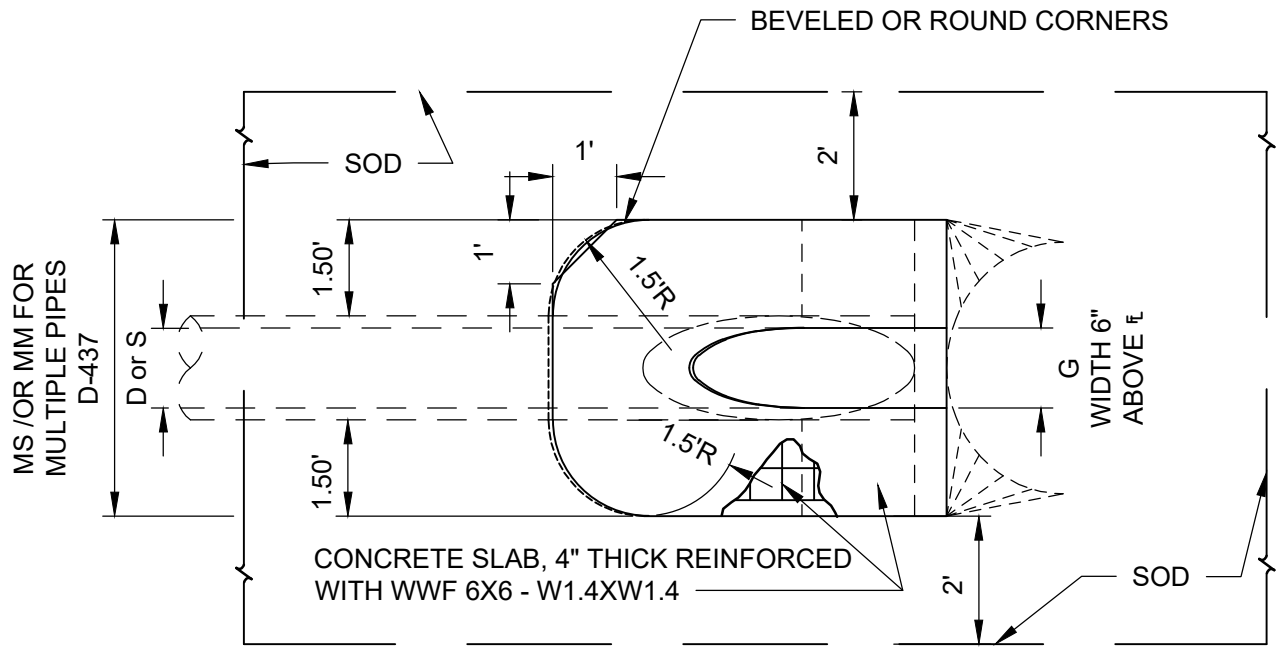

TOP VIEW - SINGLE PIPE

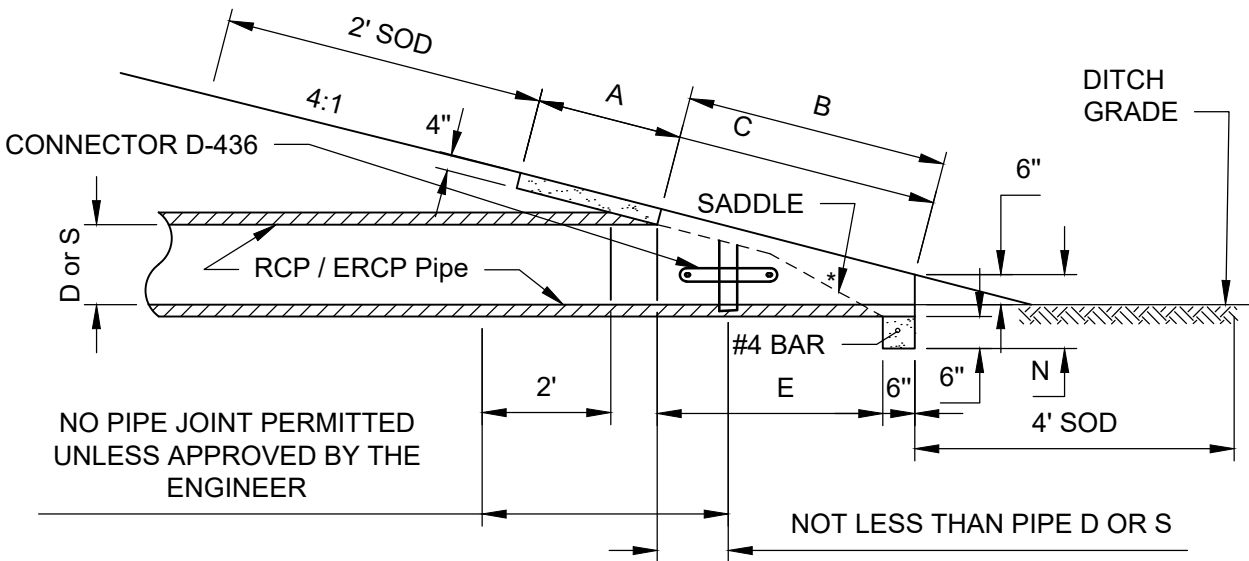

SECTION

* SLOPE:
 4:1 MITER TO ϵ OF PIPE FOR PIPES 18" & SMALLER
 2:1 MITER FOR PIPES 24" & LARGER, FOR RCP.
 4:1 MITER TO MAJOR AXIS FOR PIPES 24"X 38" & SMALLER.
 2:1 MITER FOR PIPES 29"X 45" & LARGER, FOR ERCP.

MITERED END SECTION
 FOR R.C.P. OR E.R.C.P.
 CROSS DRAIN TYPE B

CITY OF
 JACKSONVILLE
 STANDARD

N.T.S.	PLATE D-435
DATE DRAWN	06-22-89
REVISED DATE	11-21-24

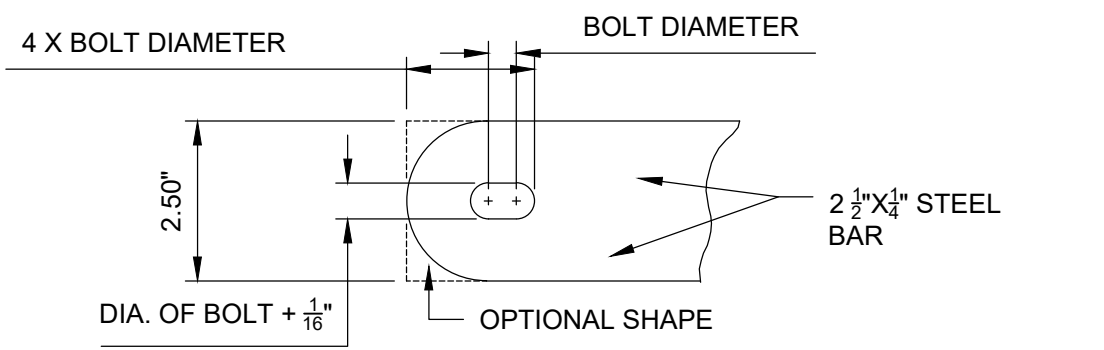
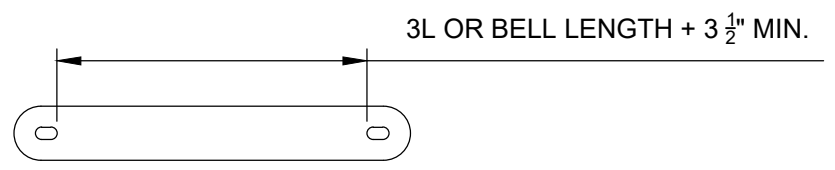
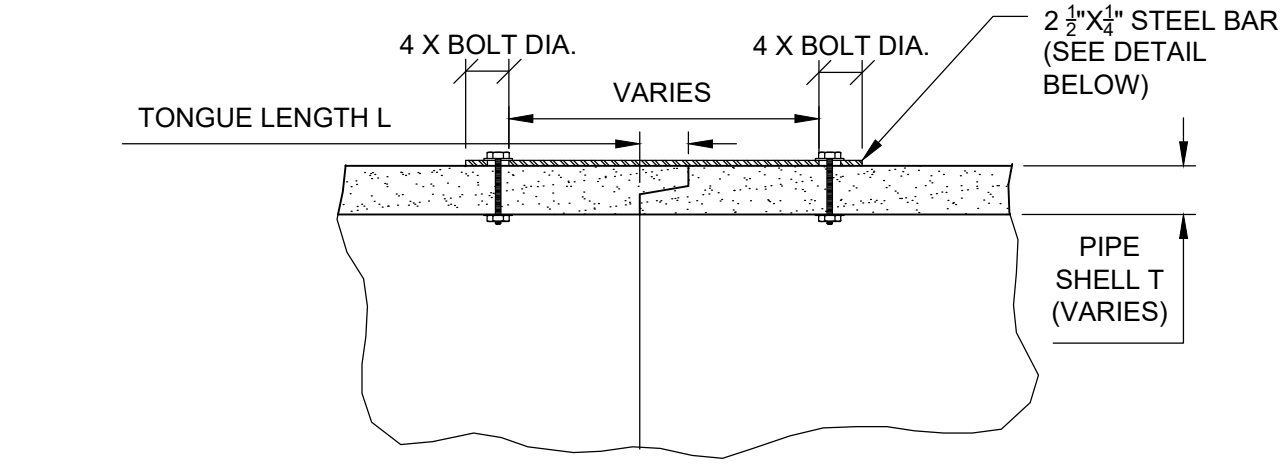
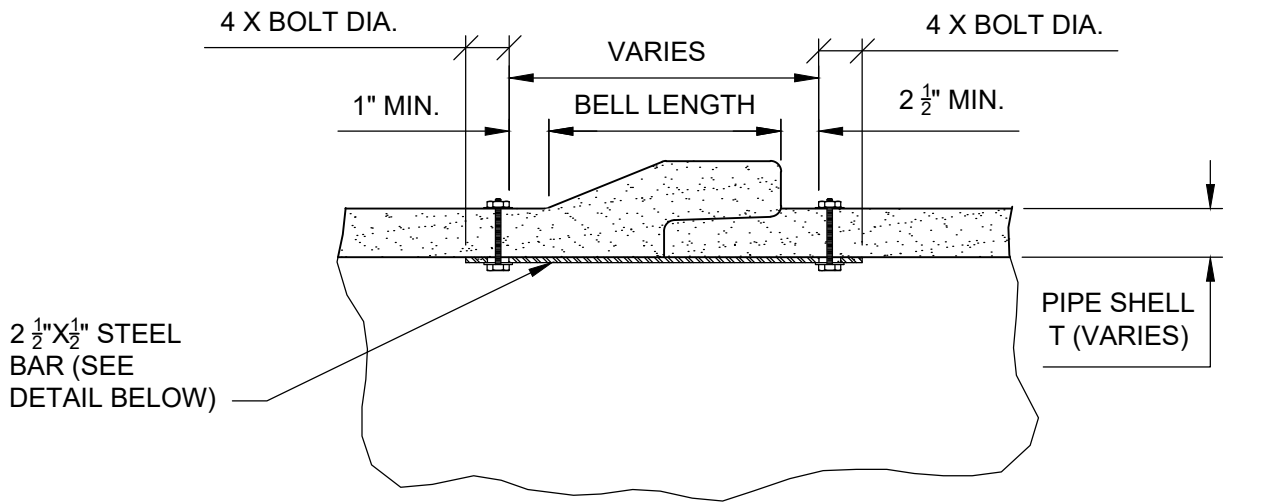

NOTES:

1. ALL BARS, BOLTS, NUTS AND WASHERS ARE TO BE GALVANIZED STEEL.
2. BOLTS DIAMETER SHALL BE 3/8" FOR 15" TO 36" PIPE AND 5/8" FOR 42" TO 72" PIPE.
3. TWO CONNECTORS REQUIRED PER JOINT, LOCATED 60° RIGHT AND LEFT OF BOTTOM CENTER OF PIPE.
4. BOLT HOLES IN PIPE SHELL ARE TO BE DRILLED.

CONNECTOR DETAIL FOR MITERED END SECTION	CITY OF JACKSONVILLE STANDARD	N.T.S.	PLATE D-436
		DATE DRAWN	06-22-89
		REVISED DATE	11-21-24

DIMENSIONS FOR R.C.P.									
D	X	A	B	C	E	F	G	Ms	N
15"	2.58'	2.27'	4.09'	6.36'	4.03'	8'	1.22'	4.63'	1.19'
18"	2.83'	2.36'	5.12'	7.48'	5.03'	9'	1.41'	4.92'	1.21'
24"	3.42'	2.53'	7.18' Δ	9.71'	7.03' Δ	11'	1.73'	5.50'	1.25'
30"	4.25'	2.70'	9.25'	11.95'	9.03'	13'	2.00'	6.08'	1.29'
36"	5.08'	2.87'	11.31' ◇	14.18'	11.03' ◇	15'	2.24'	6.67'	1.33'
42"	6.00'	3.05'	13.37'	16.42'	13.03'	17'	2.45'	7.25'	1.38'
48"	6.75'	3.22'	15.43'	18.65'	15.03'	19'	2.63'	7.83'	1.42'
54"	7.67'	3.39'	17.49'	20.88'	17.03'	21'	2.83'	8.42'	1.46'
60"	8.50'	3.56'	19.55'	23.11'	19.03'	23'	3.00'	9.00'	1.50'

Δ 6.42' Δ 6.25' DIMENSIONS PERMITTED TO ALLOW USE OF 8' STANDARD PIPE LENGTHS.

◇ 10.40' ◇ 10.10' DIMENSIONS PERMITTED TO ALLOW USE OF 12' STANDARD PIPE LENGTHS.

Δ ◇ CONCRETE SLAB SHALL BE DEEPEMED TO FROM BRIDGE ACROSS CROWN OF PIPE. SEE SECTION.

DIMENSIONS FOR E.R.C.P.										
RISE R	SPAN S	X	A	B	C	E	F	G	Ms	N
12"	18"	2.83'	2.36'	3.06'	5.42'	3.03'	5'	1.50'	4.92'	1.21'
14"	23"	3.33'	2.44'	3.75'	6.19'	3.70'	6'	1.90'	5.38'	1.23'
19"	30"	4.00'	2.62'	5.47'	8.09'	5.36'	8'	2.37'	6.04'	1.27'
24"	38"	5.00'	2.79'	7.18'	9.97'	7.03'	10'	2.85'	6.79'	1.31'
29"	45"	5.92'	3.05'	8.90'	11.95'	8.70'	12'	3.19'	7.50'	1.38'
34"	53"	7.00'	3.22'	10.62'	13.84'	10.36'	13'	3.57'	8.25'	1.42'
38"	60"	7.83'	3.39'	11.99'	15.38'	11.70'	15'	3.95'	8.92'	1.46'
43"	68"	8.92'	3.56'	13.71'	17.27'	13.36'	17'	4.28'	9.67'	1.50'
48"	76"	9.92'	3.73'	15.43'	19.16'	15.03'	19'	4.59'	10.42'	1.54'
* 53"	83"	10.67'	3.91'	17.15'	21.06'	16.70'	20'	4.77'	11.08'	1.58'
58"	91"	11.67'	4.08'	18.87'	22.95'	18.36'	22'	5.01'	11.83'	1.63'

"X"=DISTANCE FROM CENTER OF PIPE TO CENTER OF PIPE.

"Mm"=DIMENSIONS FOR MULTIPLE PIPES.

FORMULA TO DETERMINE "Mm" FOR MULTIPLE PIPES = Ms+X (NO. OF PIPES - 1)

FOR "Ms" AND "X" DIMENSIONS, SEE TABLE ABOVE.

* SPECIAL ORDER; NOT STANDARD SIZE

TABLES OF DIMENSION
FOR MITERED END
SECTIONS TYPE B

CITY OF
JACKSONVILLE
STANDARD

N.T.S.

PLATE D-437

DATE DRAWN 12-14-93

REVISED DATE 11-21-24

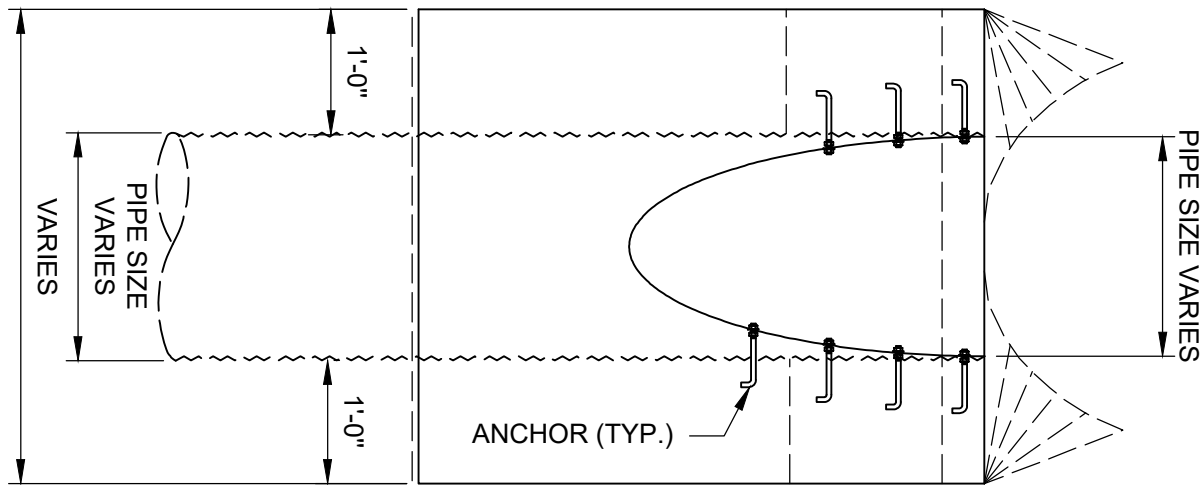

TOP VIEW-SINGLE PIPE

* VARIES BASED ON PIPE SIZE AND MES SLOPE.

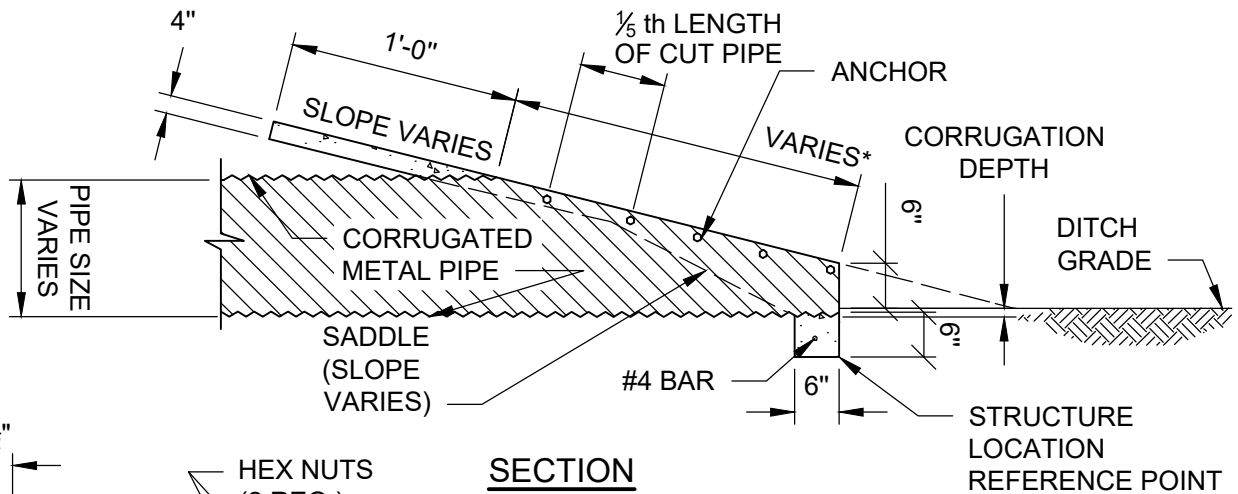

SECTION

ANCHOR NOTES:

1. ANCHOR, WASHER AND NUTS TO BE GALVANIZED STEEL.
2. BEND ANCHOR WHERE REQUIRED TO CENTER IN CONCRETE SLAB. DAMAGED SURFACES TO BE REPAIRED AFTER BENDING. ANCHORS ARE TO BE SPACED A DISTANCE EQUAL TO FOUR (4) CORRUGATIONS.
3. PLACE THE ANCHORS IN THE OUTSIDE CREST OF CORRUGATION. FLAT WASHERS TO BE PLACED ON INSIDE WALL OF PIPE.
4. HOLES IN THE MITERED END PIPE ARE TO BE DRILLED OR PUNCHED: BURNING NOT PERMITTED.

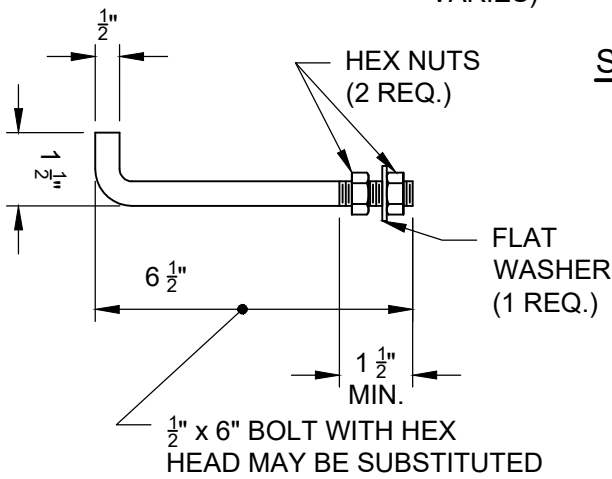

ANCHOR DETAIL

NOTE: THE COST OF ALL REINFORCING ANCHORS AND CONCRETE SHALL BE INCLUDED IN THE COST FOR THE MITERED END SECTION. NO PIPING SHALL BE INCLUDED IN THE COST FOR THE MITERED END SECTION. MITERED END SECTIONS WILL BE PAID FOR UNDER THE CONTRACT PRICE FOR MITERED END SECTION (EACH) AS ESTABLISHED IN THE BID PROPOSAL.

CMP OR CMPA MITERED
END SECTION DETAIL

CITY OF
JACKSONVILLE
STANDARD

N.T.S.

PLATE D-438

DATE DRAWN 9-02-11

REVISED DATE 11-21-24

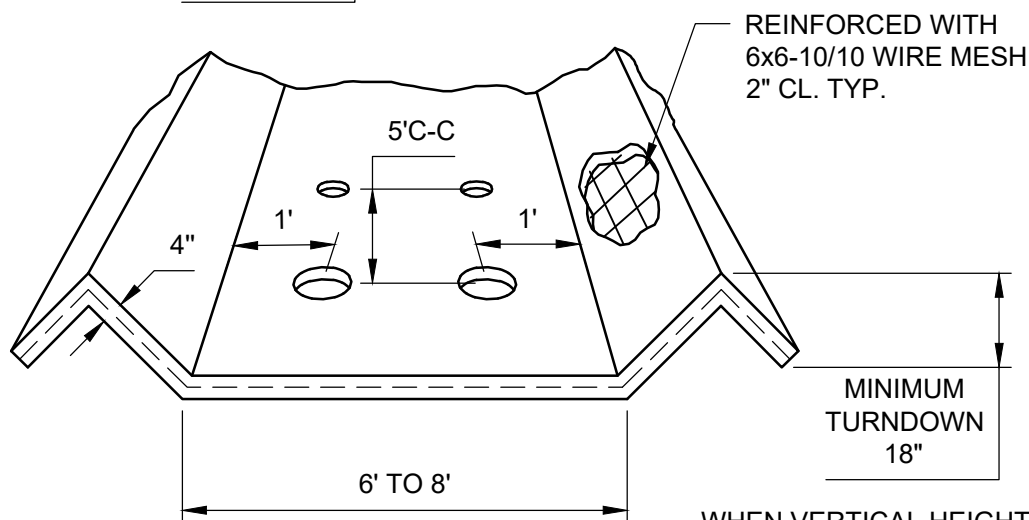
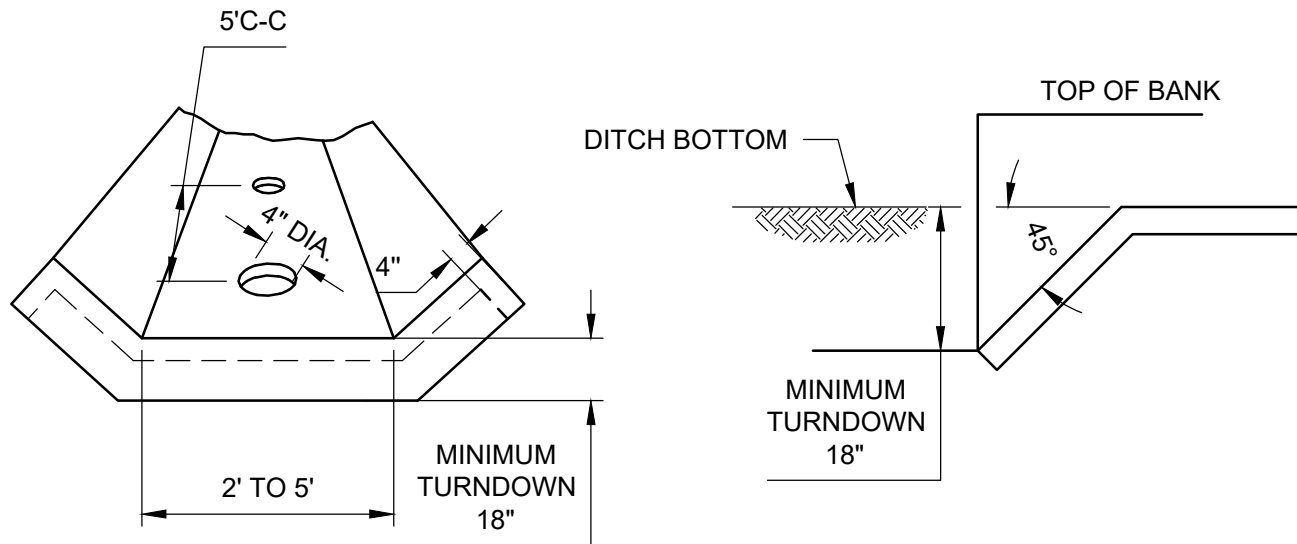

DITCH PAV'T. SECTION

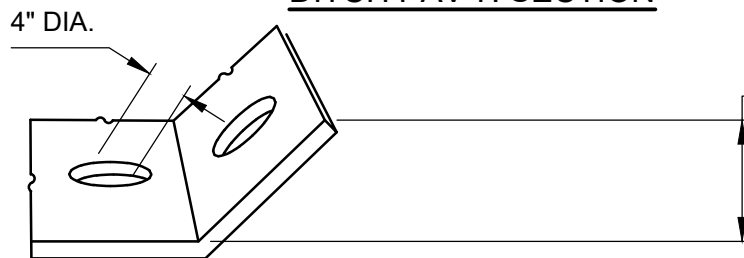

WHEN VERTICAL HEIGHT IS GREATER THAN 3' CONST. WEEP HOLES HALFWAY UP THE SIDE IN LINE WITH BOTTOM WEEP HOLES.

NOTES:

- 1) JOINTS SHALL BE OF EITHER THE OPEN TYPE OR THE TOOLED (DUMMY) TYPE AND NOT SPACED MORE THAN 10 FT. APART.
- 2) CONC. DESIGN STRENGTH 2500 P.S.I. MIN.
- 3) ONE CU.FT. OF #67 COARSE AGGREGATE AND 1/4" GALV. HARDWARE CLOTH BETWEEN GRAVEL AND UNDERSIDE OF THE DITCH PAV'T. TO BE PLACED BENEATH EACH WEEP HOLE.
- 4) WEEP HOLE ARRANGEMENT MAY BE MODIFIED OR ADDITIONAL WEEP HOLES REQUIRED AT THE DIRECTION OF THE ENGINEER.

CONC. DITCH PAVING AND WEEP HOLE ARRANGEMENT	CITY OF JACKSONVILLE STANDARD		N.T.S.	PLATE D-501
			DATE DRAWN	7-14-79
			REVISED DATE	11-21-24

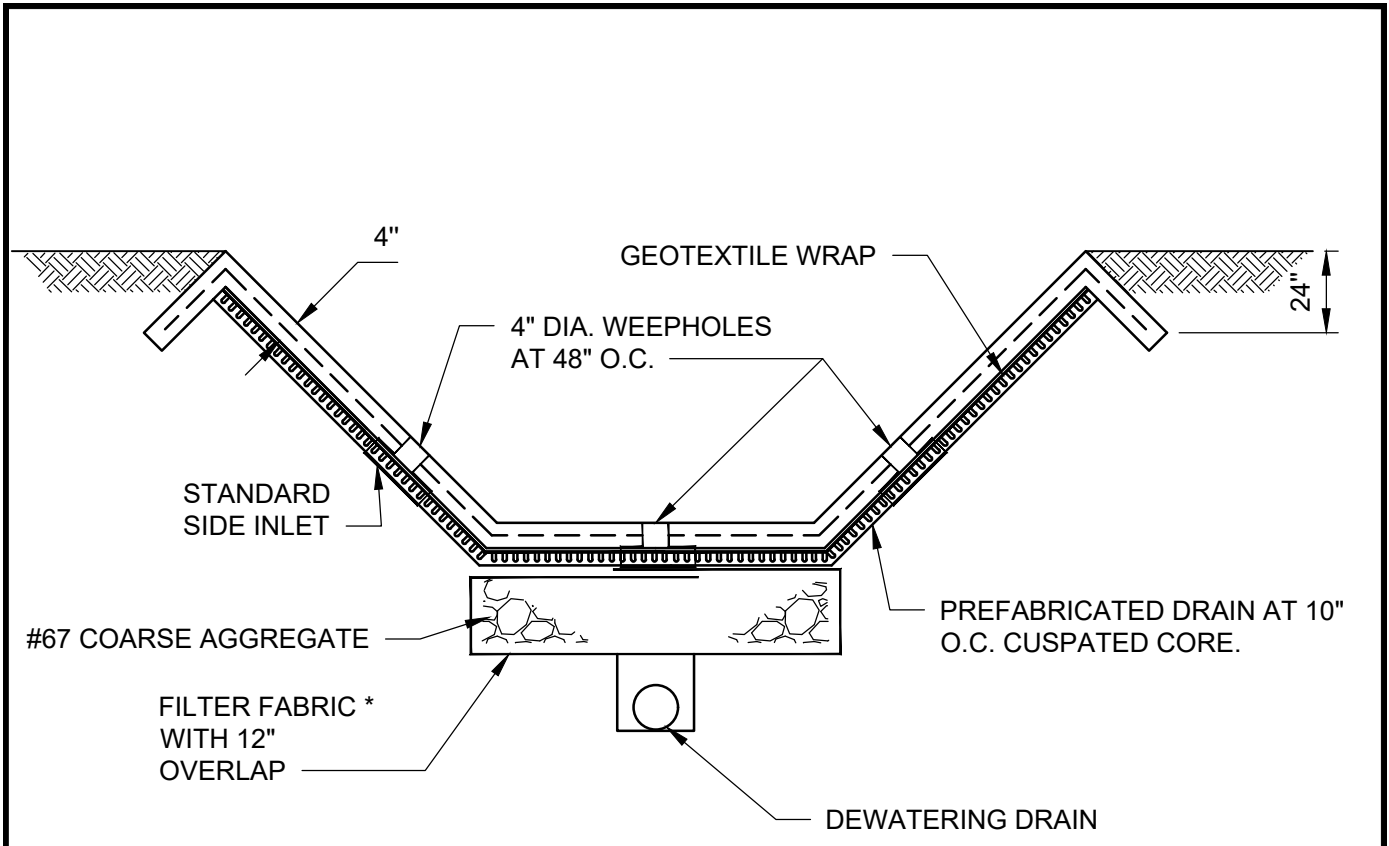

* WHEN DEWATERING REQUIRES CRUSHED STONE AND/OR DEWATERING DRAIN THE ENTIRE SYSTEM SHALL BE WRAPPED IN FILTER FABRIC.

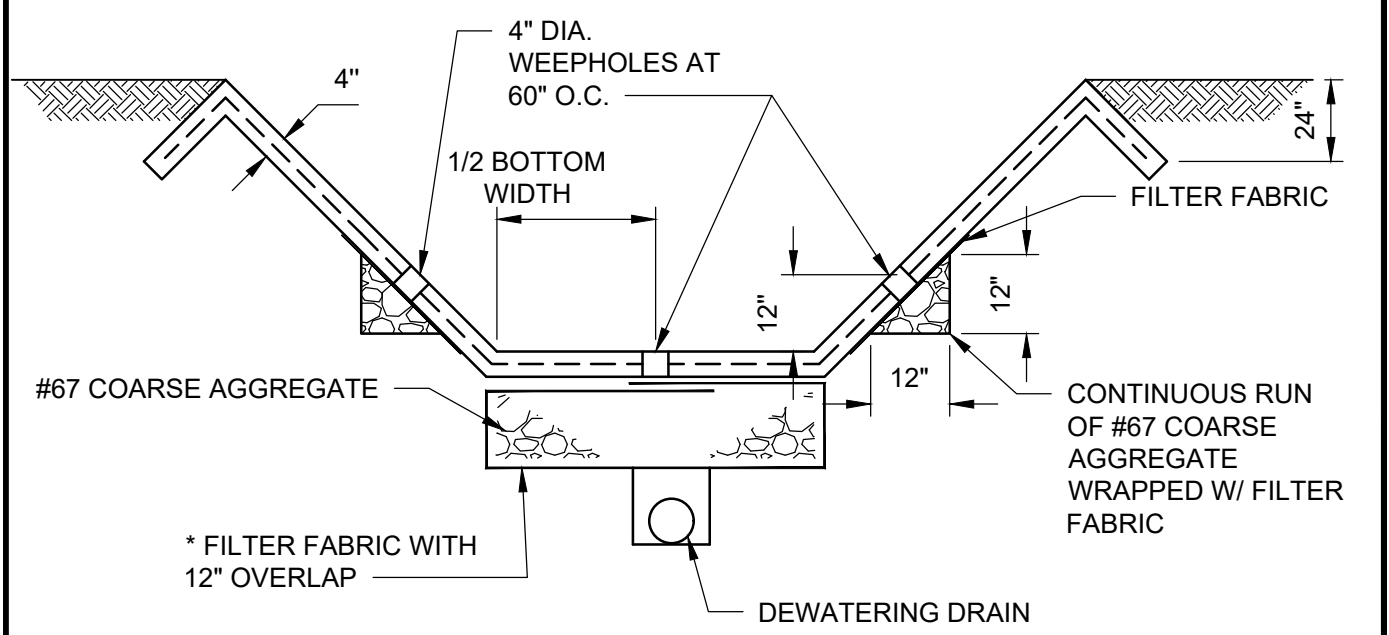

ALTERNATE WEEPHOLE DETAIL	CITY OF JACKSONVILLE STANDARD	N.T.S.	PLATE D-502
		DATE DRAWN	5-12-94
		REVISED DATE	11-21-24

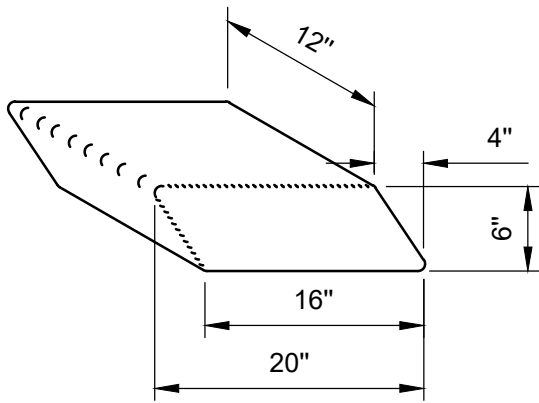
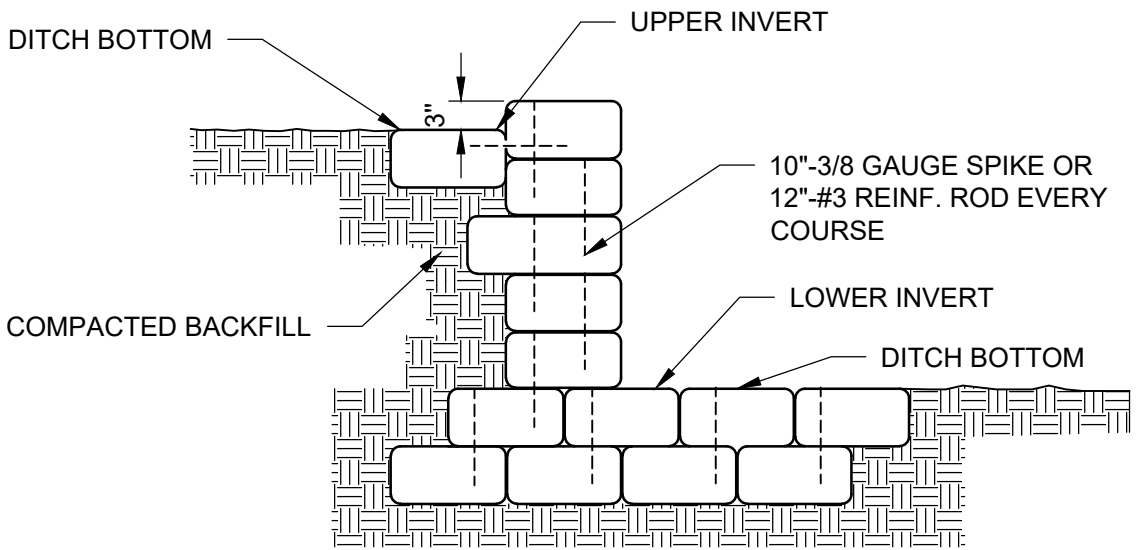

BAG DETAIL

COUNTERSINK ALL EXPOSED SPIKES OR REINF. RODS 1"

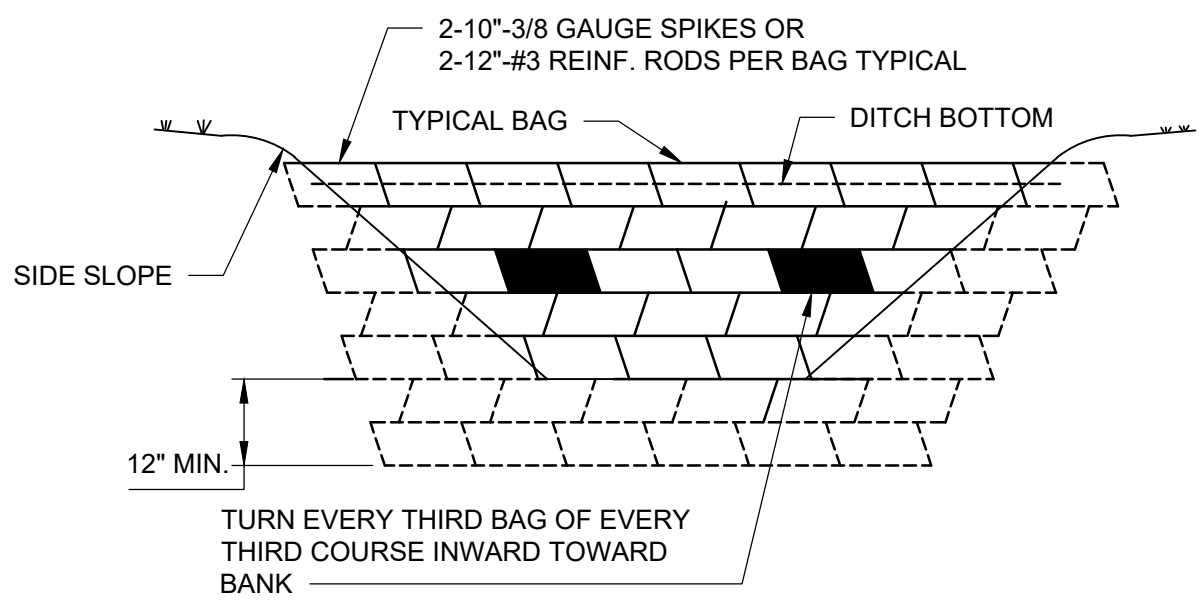

TEMPORARY
SAND-CEMENT RIP
RAP CHECK DAM

CITY OF
JACKSONVILLE
STANDARD

N.T.S.

PLATE D-601

DATE DRAWN 2-10-79

REVISED DATE 11-21-24

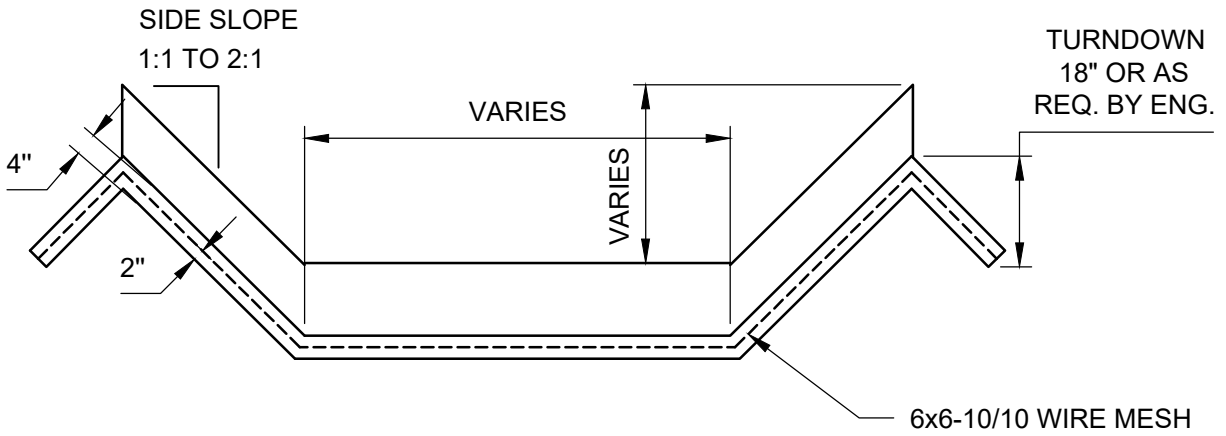
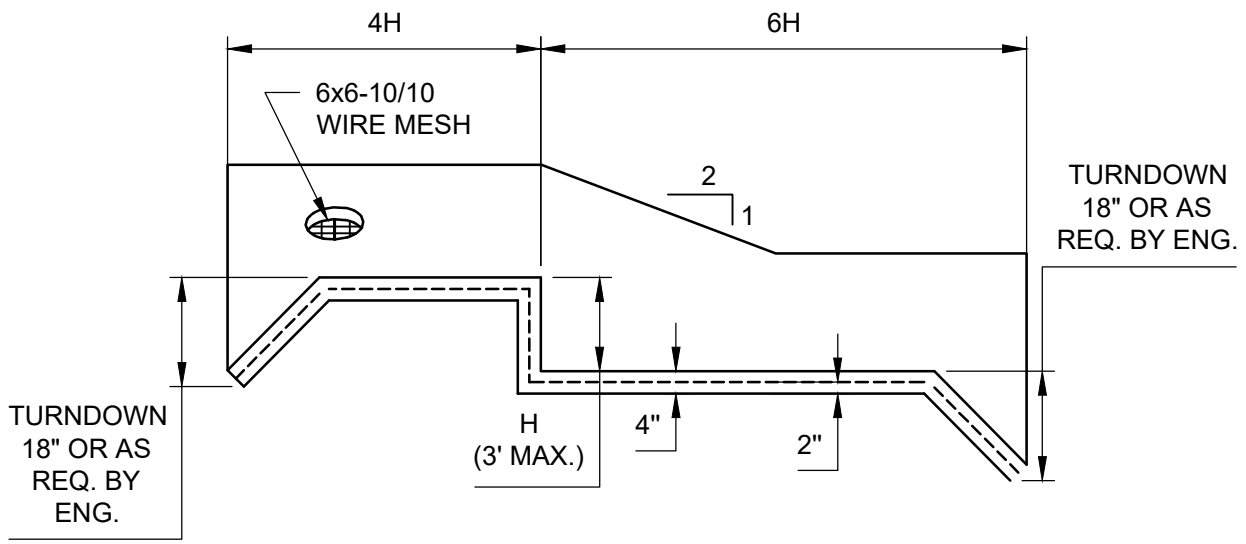

NOTES:

1. CONC. DESIGN STRENGTH 2500 P.S.I. MIN.
2. FOR WEEP HOLE NEEDS-SEE PLATE D-501

CONC. CHECK DAM	CITY OF JACKSONVILLE STANDARD	N.T.S.	PLATE D-602
		DATE DRAWN	7-14-79
		REVISED DATE	11-21-24

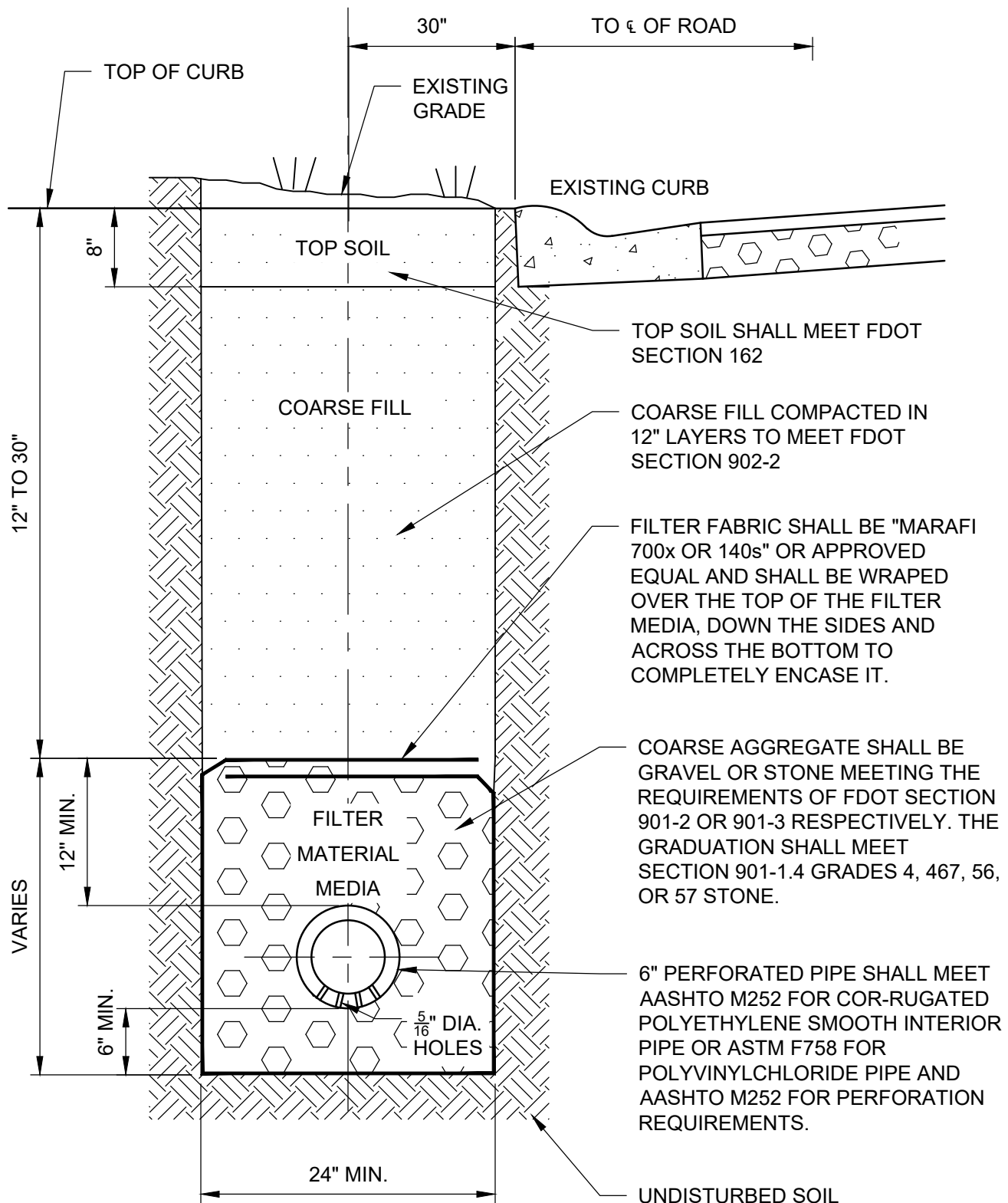

NOTES:

1. MINIMUM PIPE SLOPE OF 0.30%
2. TYPE I UNDERDRAIN WITH "MARAFI 700x" OR APPROVED EQUAL IS TO BE USED WHERE MODERATE CHEMICAL CLOGGING OF FILTER MATERIAL IS EXPECTED.

UNDERDRAIN INSTALLATION TYPE I	CITY OF JACKSONVILLE STANDARD	N.T.S.	PLATE D-701
		DATE DRAWN 05-12-79	
		REVISED DATE 11-21-24	

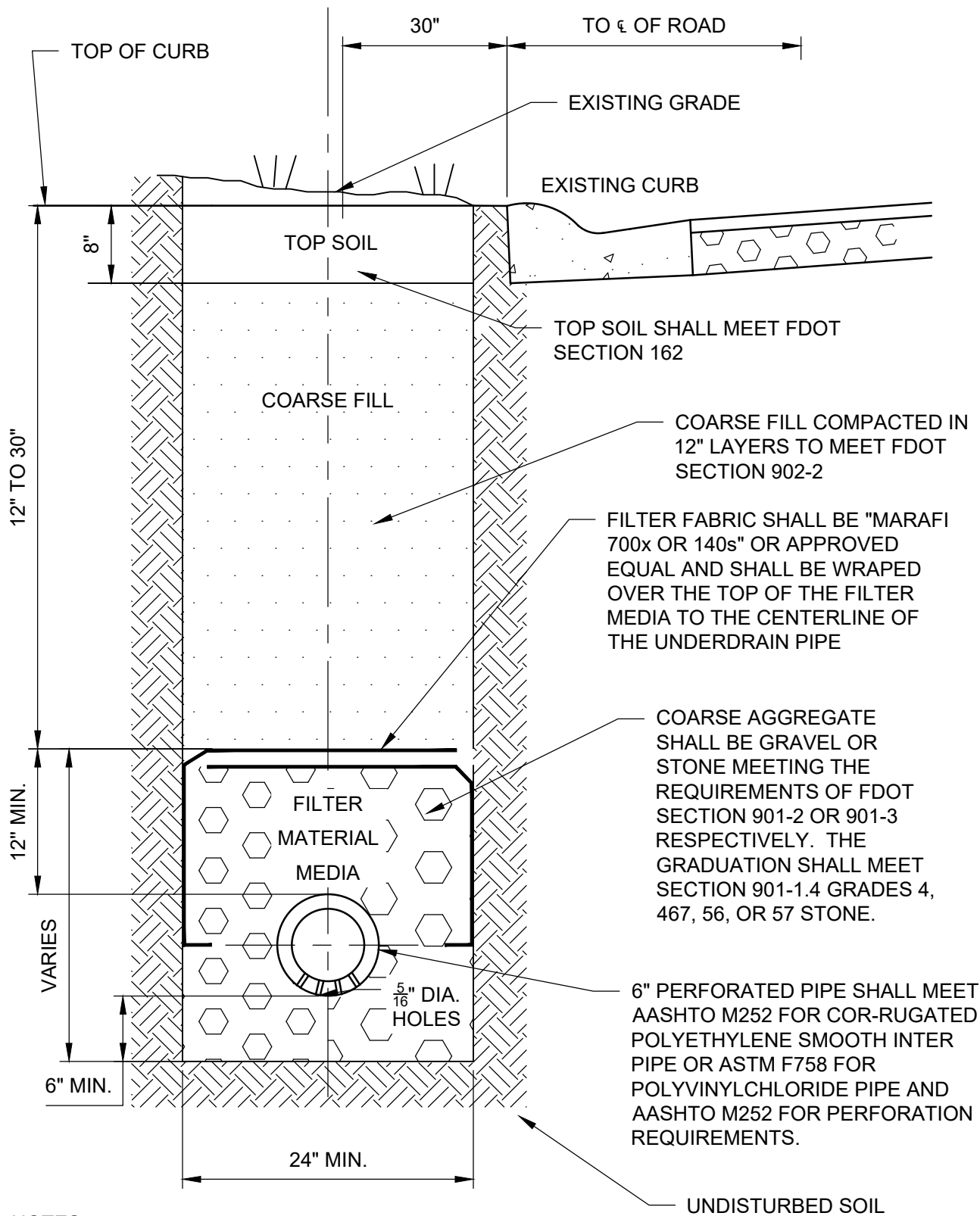

NOTES:

1. MINIMUM PIPE SLOPE OF 0.30%
2. TYPE II UNDERDRAIN IS TO BE USED WHERE CHEMICAL CLOGGING OF FILTER FABRIC IS ANTICIPATED

UNDERDRAIN INSTALLATION TYPE II	CITY OF JACKSONVILLE STANDARD	N.T.S.	PLATE D-702
		DATE DRAWN	05-12-79
		REVISED DATE	11-21-24

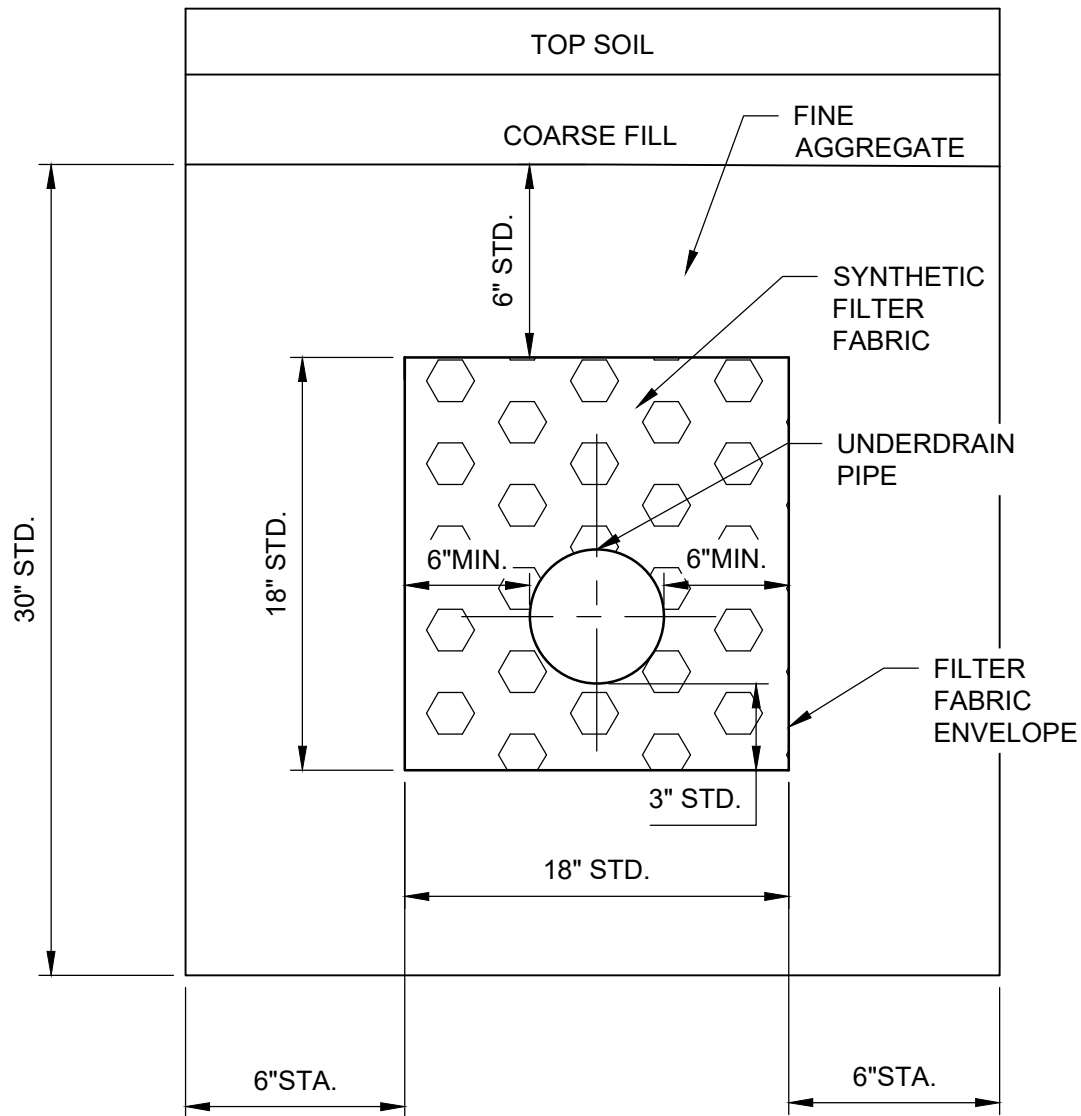

TYPE III

GENERAL NOTES FOR UNDERDRAIN:

1. TYPE III UNDERDRAIN IS INTENDED FOR MAXIMUM WATER REMOVAL CONDITIONS. THE FILTER FABRIC SEPARATION IS REQUIRED BETWEEN THE COARSE AGGREGATE OR FINE AGGREGATE INCLUDING THOSE DESCRIBED IN GENERAL NOTES 2 AND 3 WHERE REACTIVE CONDITIONS MAY CREATE CHEMICAL CLOGGING, THE USE OF AN INERT MATERIAL AND/OR ELIMINATION OF THE FILTER FABRIC MAY BE NECESSARY.
2. FINE AGGREGATE SHALL BE QUARTZ SAND MEETING THE REQUIREMENTS OF FDOT SECTION 902-4 OF THE STANDARD SPECIFICATIONS.
3. COARSE AGGREGATE SHALL BE GRAVEL OR STONE MEETING THE REQUIREMENTS OF SECTION 901-2 OR 901-3 RESPECTIVELY. THE GRADATION SHALL MEET FDOT SECTION 901-6, GRADES 4, 467, 5, 56, OR 57 STONE UNLESS RESTRICTED IN THE PLANS.

UNDERDRAIN INSTALLATION TYPE III	CITY OF JACKSONVILLE STANDARD	N.T.S.	PLATE D-703
		DATE DRAWN	5-12-79
		REVISED DATE	11-21-24

SCREW TYPE PLUG
W/CLEANOUT ADAPTER
CLEARANCE 1" MIN.- 3" MAX.

UNDERDRAIN ACCESS 14 1/4"x19 1/2"x12" DEEP, PLASTIC
WATER METER BOX WITH SOLID COVER.

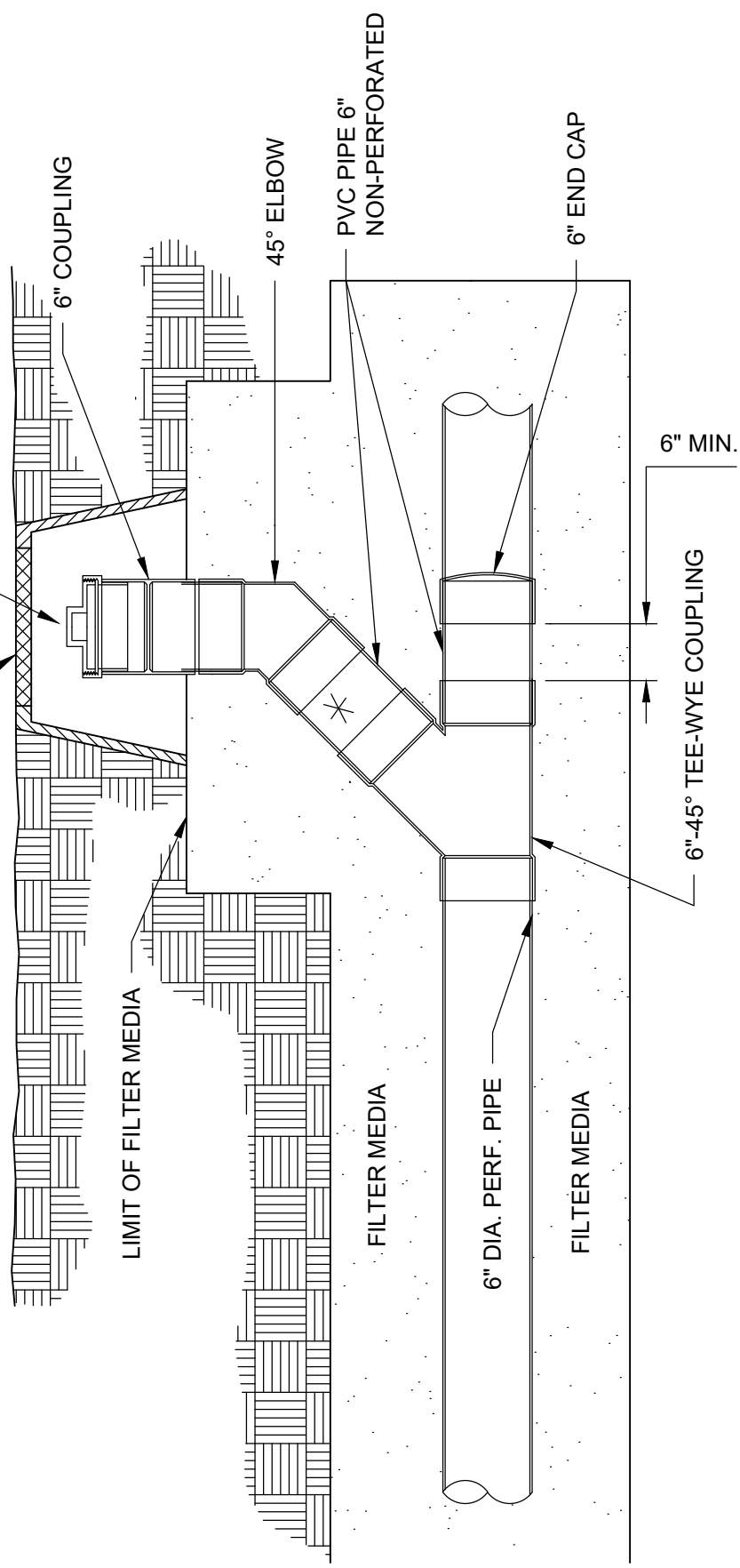

NOTES:

ALL PIPE AND FITTINGS TO MEET ASTM F758-82 SPECIFICATIONS. 300' MAXIMUM DISTANCE BETWEEN CLEANOUTS .

* COUPLING PIPE LENGTH TO BE FIELD ADJUSTED.

UNDERDRAIN
CLEANOUT DETAIL

CITY OF
JACKSONVILLE
STANDARD

N.T.S.
DATE DRAWN
REVISED DATE

PLATE D-704
5-07-79
11-21-24

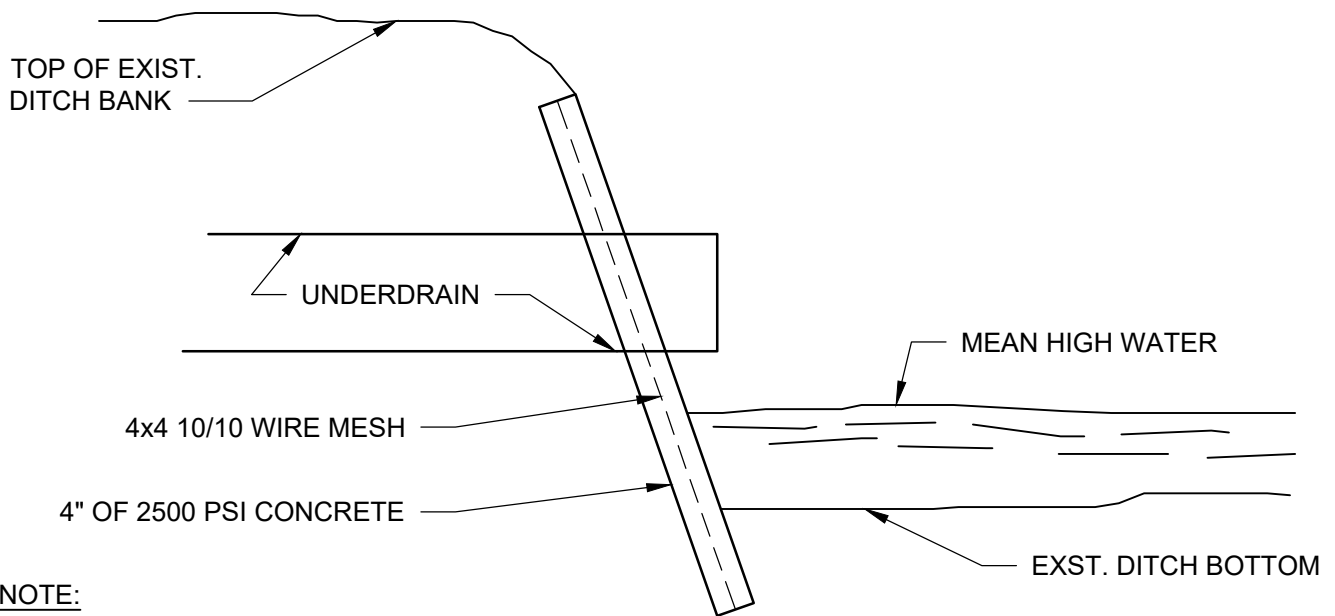
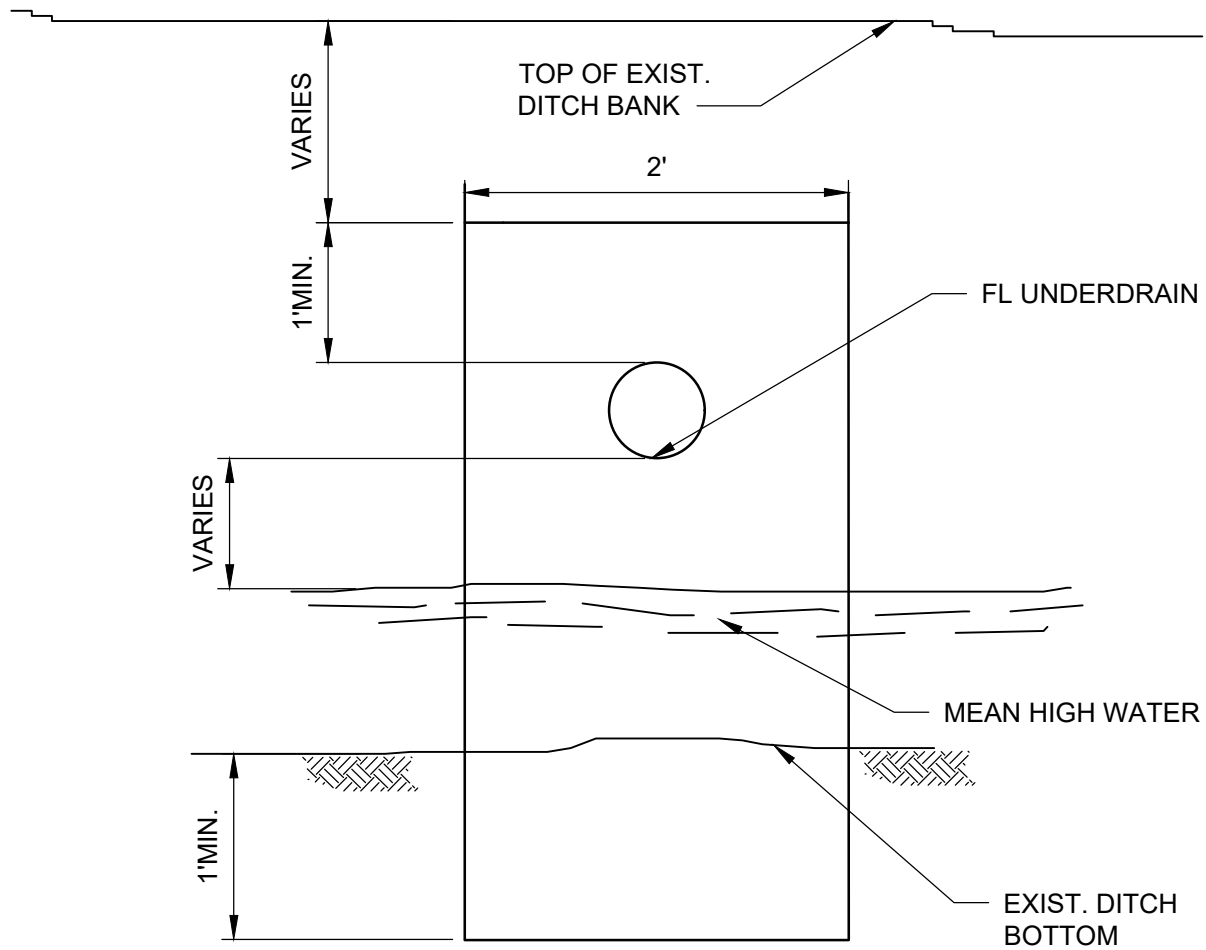

NOTE:
SLAB MAY BE PRECAST

PAVED OUTFALL
FOR UNDERDRAIN

CITY OF
JACKSONVILLE
STANDARD

N.T.S.

PLATE D-705

DATE DRAWN 5-5-79

REVISED DATE 11-21-24

TYPICAL PREFABRICATED EDGE DRAIN

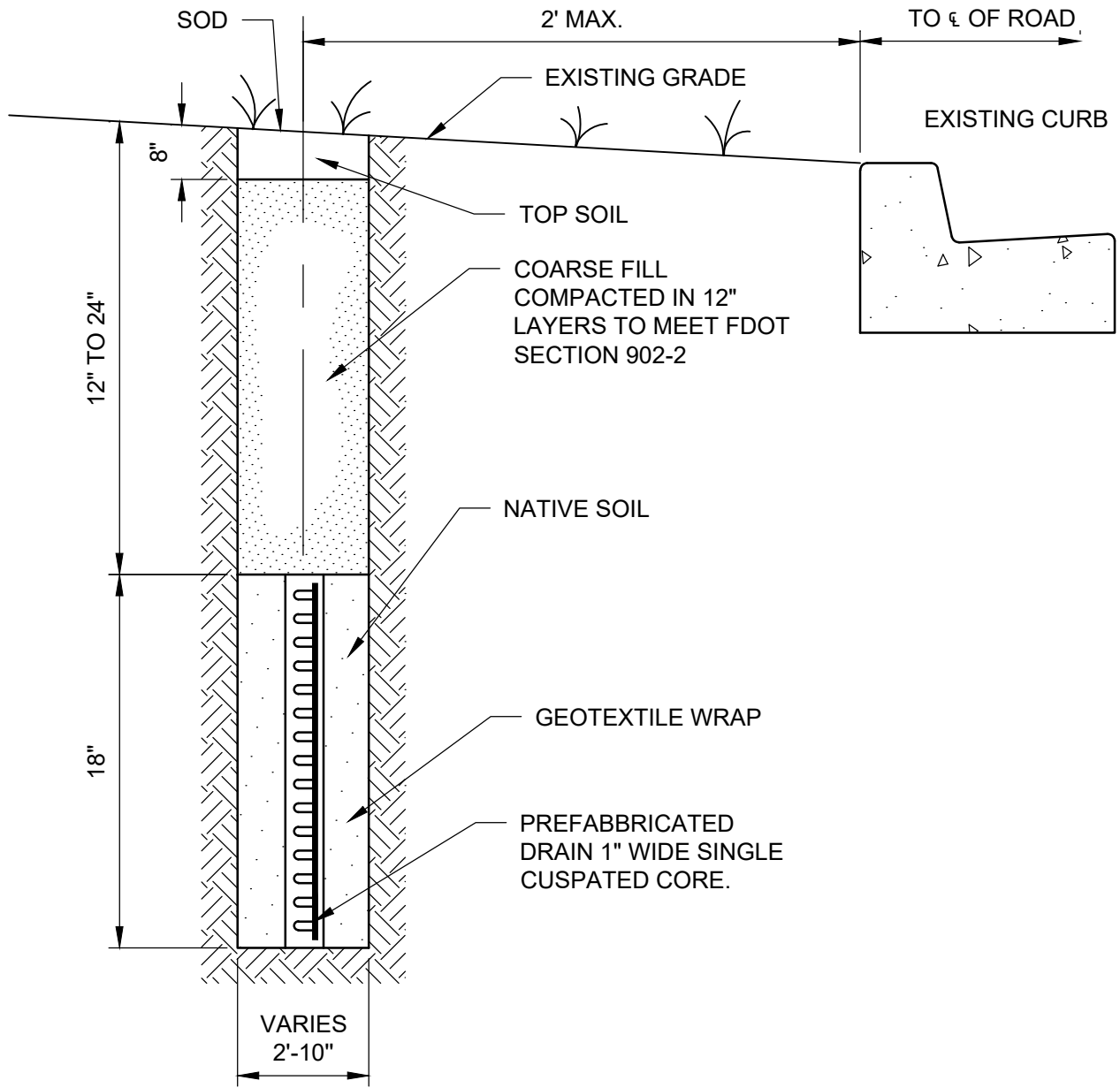

NOTE:
MINIMUM PIPE SLOPE OF 0.30%

PREFABRICATED EDGE DRAIN DETAIL	CITY OF JACKSONVILLE STANDARD	N.T.S.	PLATE D-706
		DATE DRAWN	4-28-79
		REVISED DATE	11-21-24

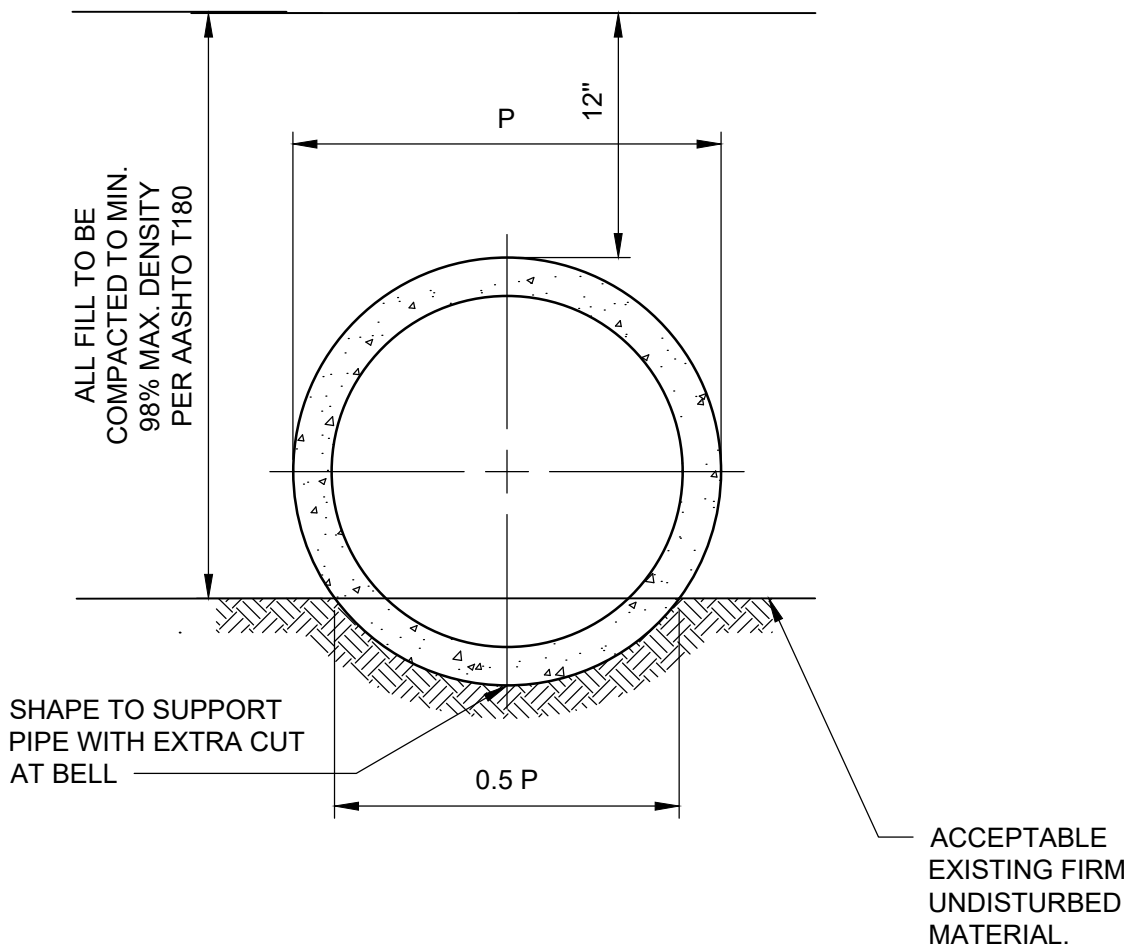

NOTES:

1. EACH LIFT TO BE COMPLETELY COMPACTED TO REQUIRED DENSITY BEFORE STARTING NEXT LIFT.
2. NO LIFT TO EXCEED 6" WHEN COMPACTED.

PIPE BEDDING CASE 1	CITY OF JACKSONVILLE STANDARD	N.T.S.	PLATE D-801
		DATE DRAWN	8-5-79
		REVISED DATE	11-21-24

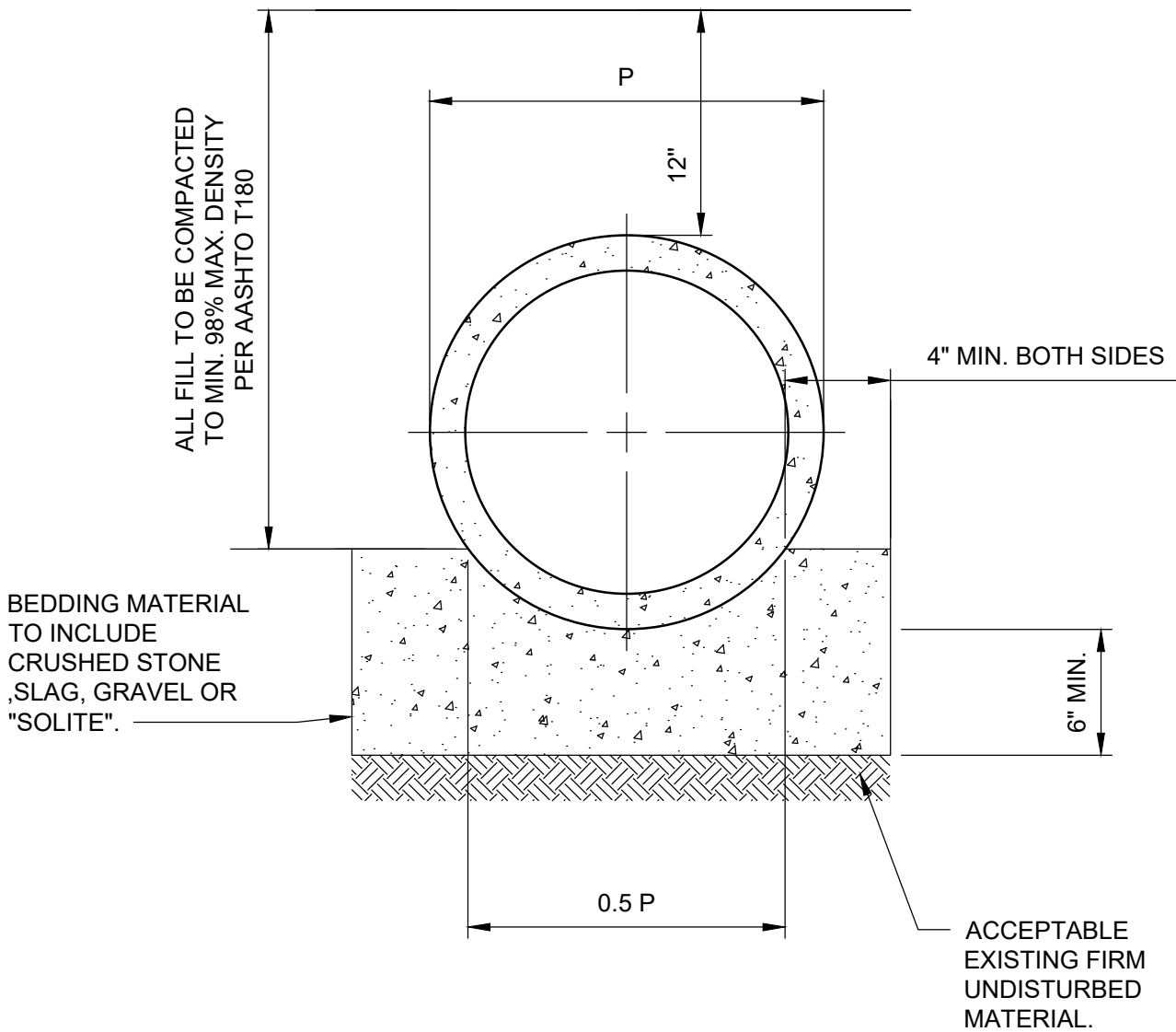

NOTES:

1. TO FACILITATE DEWATERING, POCKETS CAN BE UNDERCUT AT CONVENIENT INTERVALS & FILLED WITH GRAVEL TO ESTABLISH LOCATIONS FOR SUCTION END OF DEWATERING PUMP.
2. EACH LIFT TO BE COMPLETELY COMPACTED TO REQUIRED DENSITY BEFORE STARTING NEXT LIFT. NO LIFT TO EXCEED 6" WHEN COMPACTED.

PIPE BEDDING CASE 2	CITY OF JACKSONVILLE STANDARD	N.T.S.	PLATE D-802
		DATE DRAWN	8-5-79
		REVISED DATE	11-21-24

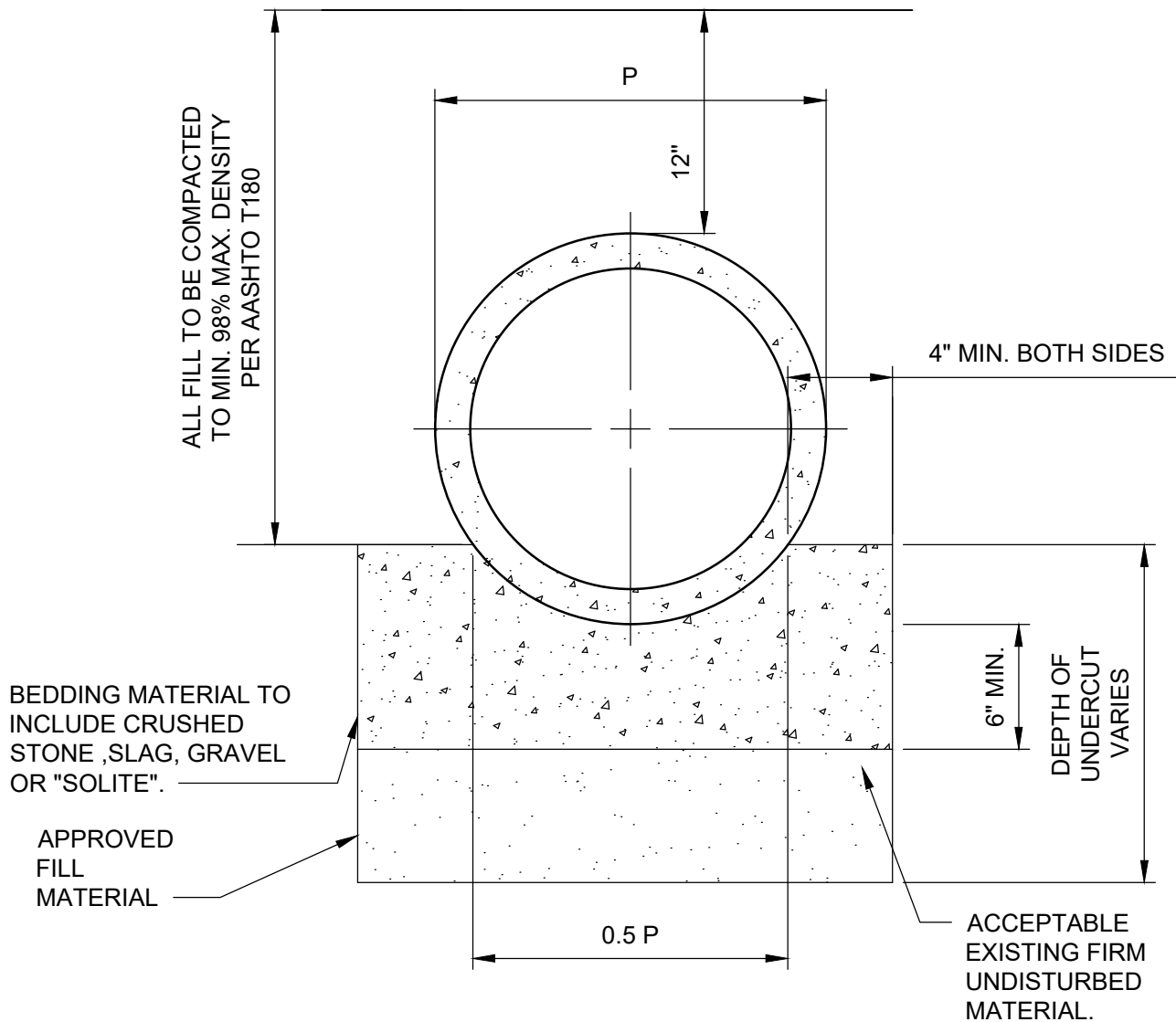

NOTES:

1. TO FACILITATE DEWATERING, POCKETS CAN BE UNDERCUT AT CONVENIENT INTERVALS & FILLED WITH GRAVEL TO ESTABLISH LOCATIONS FOR SUCTION END OF DEWATERING PUMP.
2. EACH LIFT TO BE COMPLETELY COMPACTED TO REQUIRED DENSITY BEFORE STARTING NEXT LIFT. NO LIFT TO EXCEED 6" WHEN COMPACTED.

PIPE BEDDING CASE 3	CITY OF JACKSONVILLE STANDARD	N.T.S.	PLATE D-803
		DATE DRAWN	8-5-79
		REVISED DATE	11-21-24

LIMEROCK COMPACTED
TO MIN. 98% MAX.
DENSITY PER
A.A.S.H.T.O. T180

PAVING

LIFTS NOT TO
EXCEED 6" WHEN
COMPACTED.

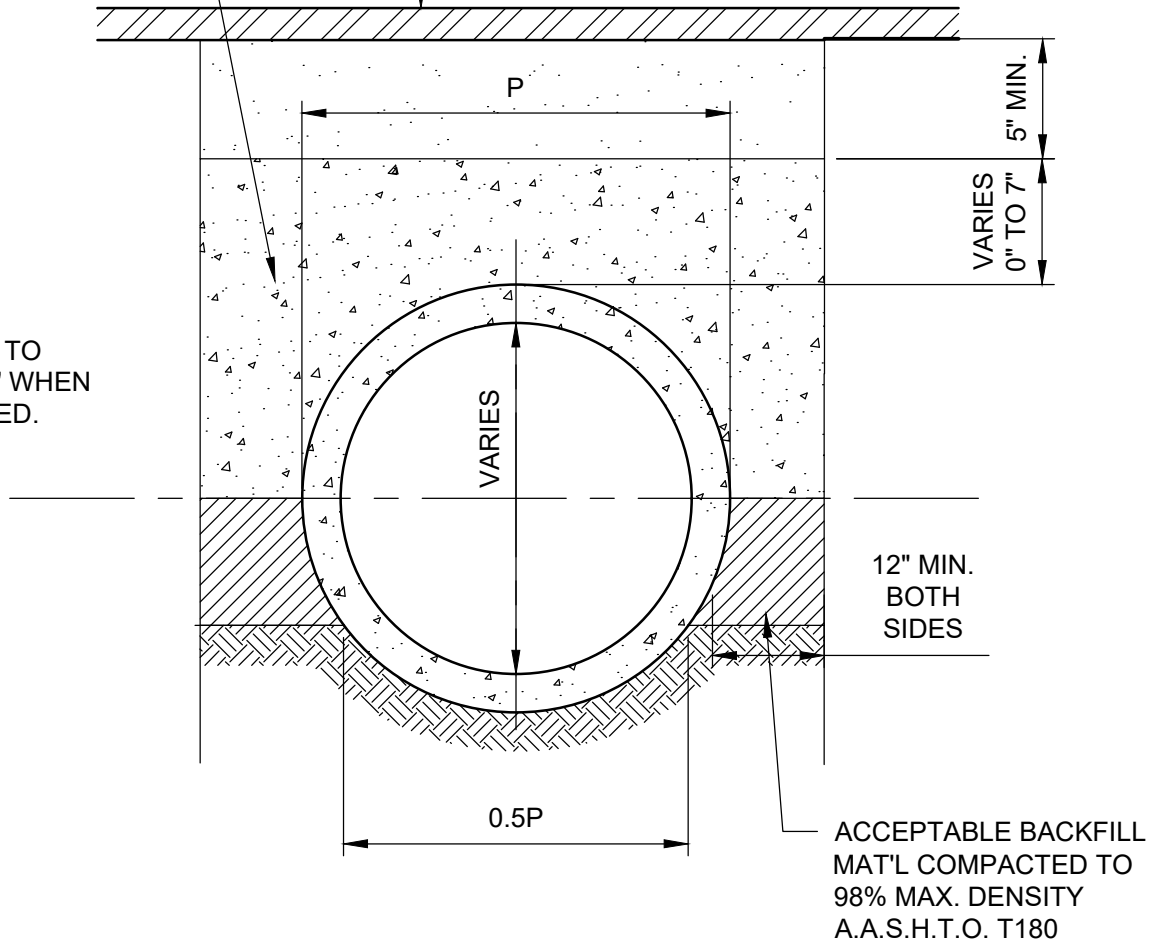

NOTE:

THIS STANDARD IS TO BE USED ONLY WHEN EXISTING
CONDITIONS REQUIRED LESS THEN THE STANDARD 12" OF COVER
& WHEN IT IS SHOWN THAT TRAFFIC LOADS WILL NOT DAMAGE
THE PIPE. SPECIAL APPROVAL BY CITY ENGINEER IS REQUIRED
FOR USE OF THIS STANDARD.

CULVERT PLACEMENT
WITH LESS THAN 12"
COVER

CITY OF
JACKSONVILLE
STANDARD

N.T.S.

PLATE D-804

DATE DRAWN 8-5-79

REVISED DATE 11-21-24

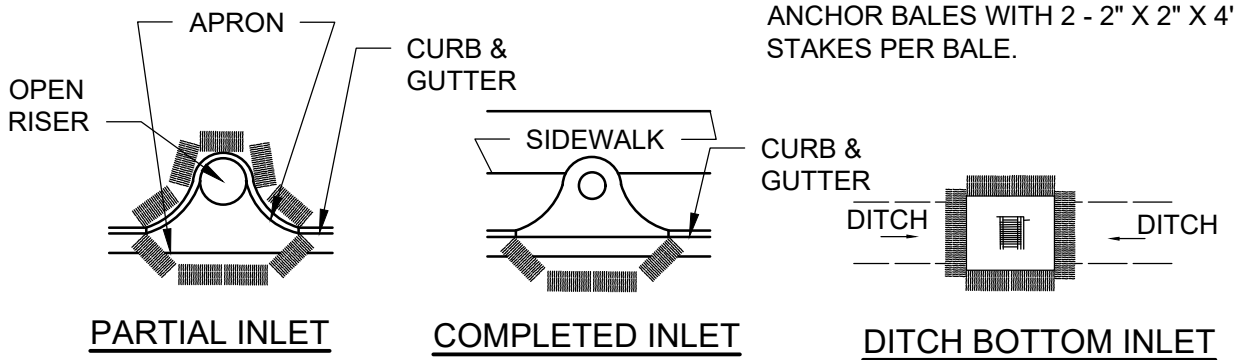

PROTECTION AROUND INLETS OR SIMILAR STRUCTURES

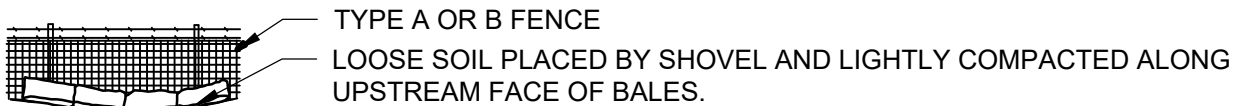

BALES BACKED BY FENCE

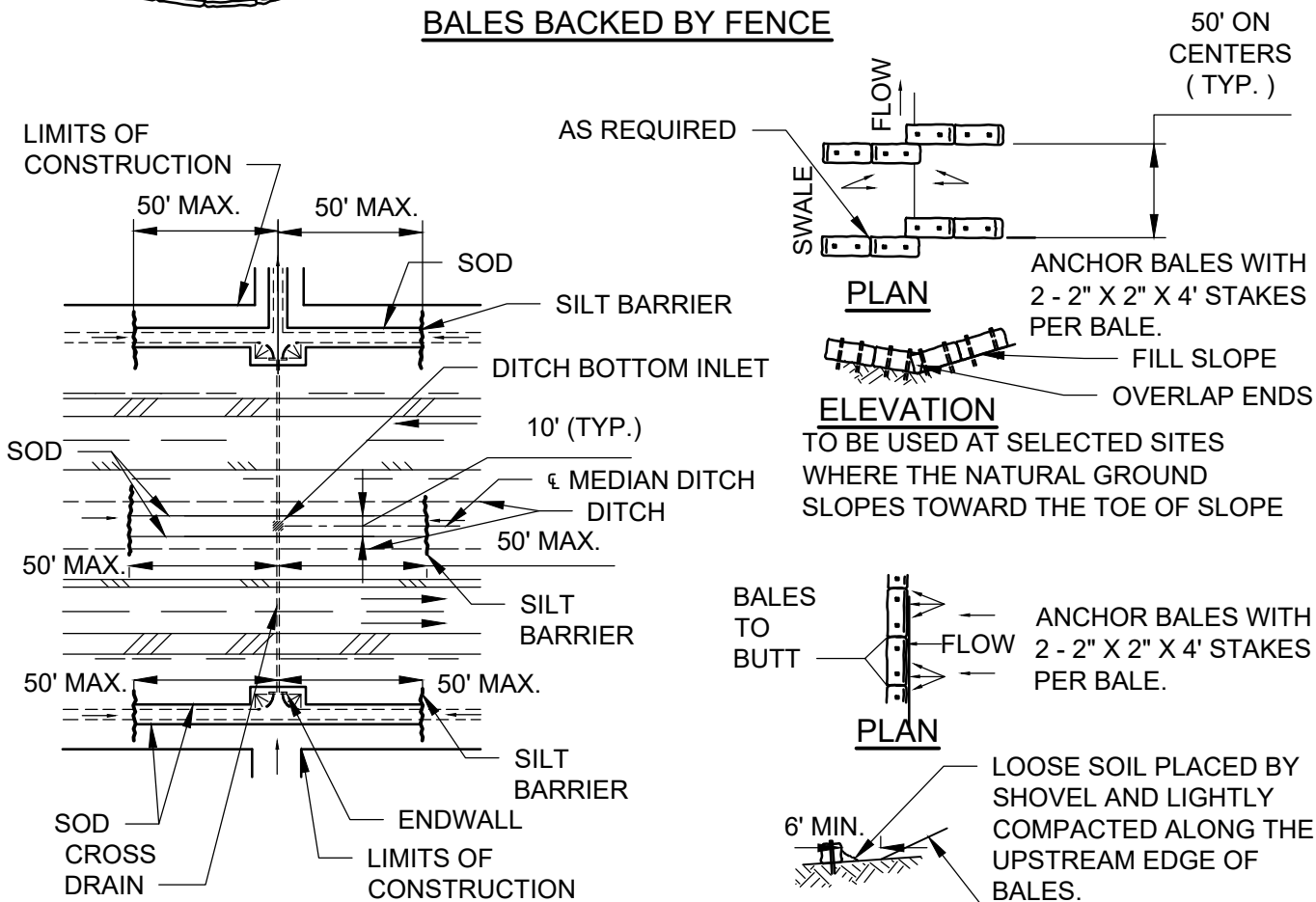

DITCH INSTALLATIONS AT DRAINAGE STRUCTURES

BARRIERS FOR FILL SLOPES

NOTE: BALES TO BE STAKED AT THE DIRECTION OF THE ENGINEER.

BALE LOCATION	CITY OF JACKSONVILLE STANDARD	N.T.S.	PLATE D-901
		DATE DRAWN	2-20-79
		REVISED DATE	11-21-24

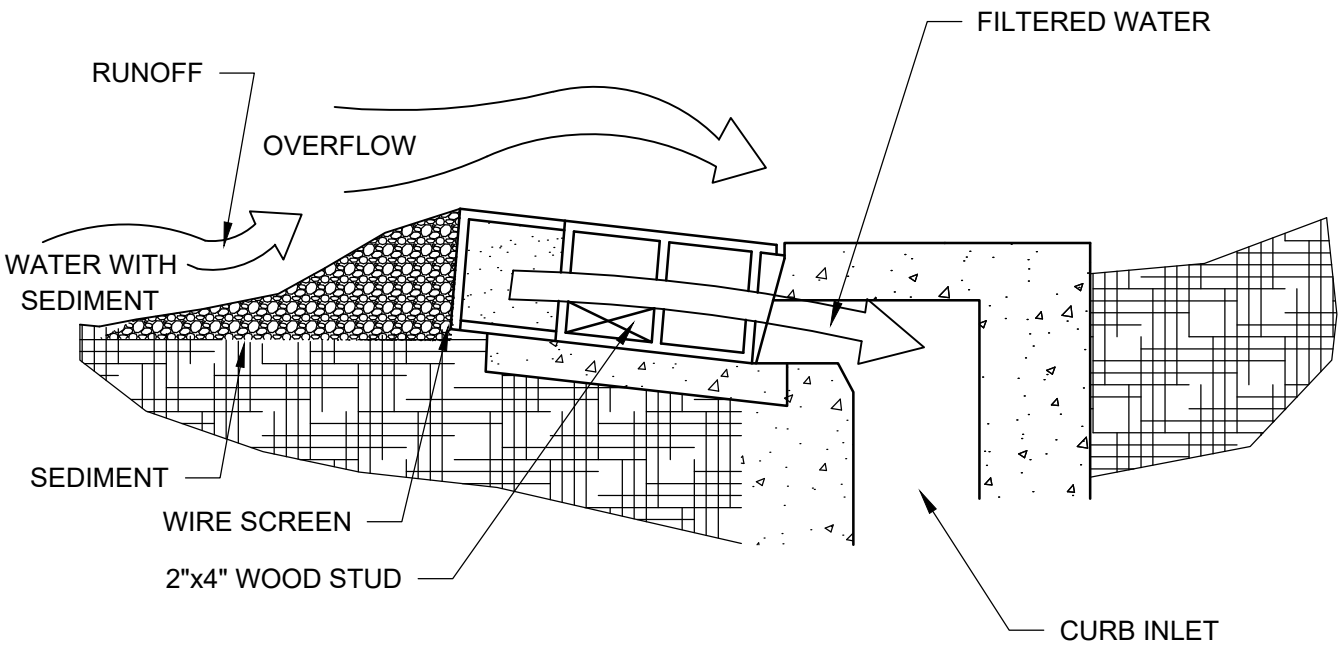
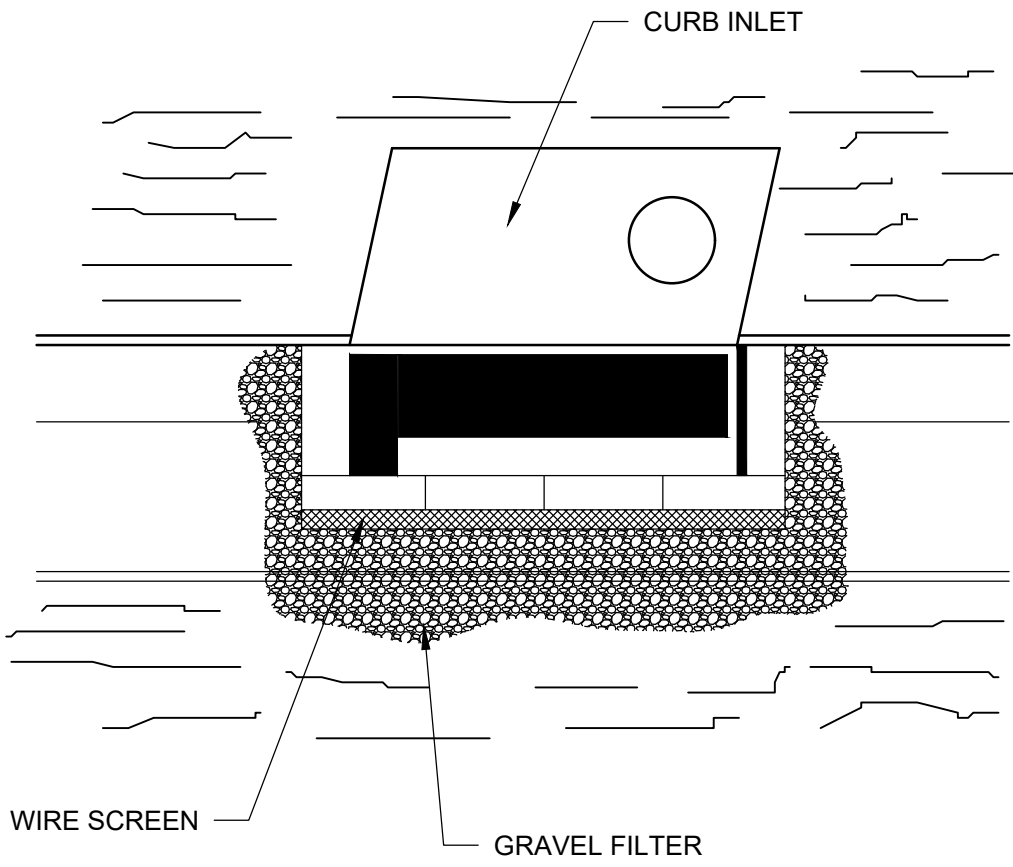

SPECIFIC APPLICATION:

THIS METHOD OF INLET PROTECTION IS APPLICABLE AT CURB INLETS WHERE AN OVERFLOW CAPABILITY IS NECESSARY TO PREVENT EXCESSIVE PONDING IN FRONT OF THE STRUCTURE.

BLOCK AND GRAVEL CURB INLET SEDIMENT FILTER	CITY OF JACKSONVILLE STANDARD	N.T.S.	PLATE D-902
		DATE DRAWN	8-4-79
		REVISED DATE	11-21-24

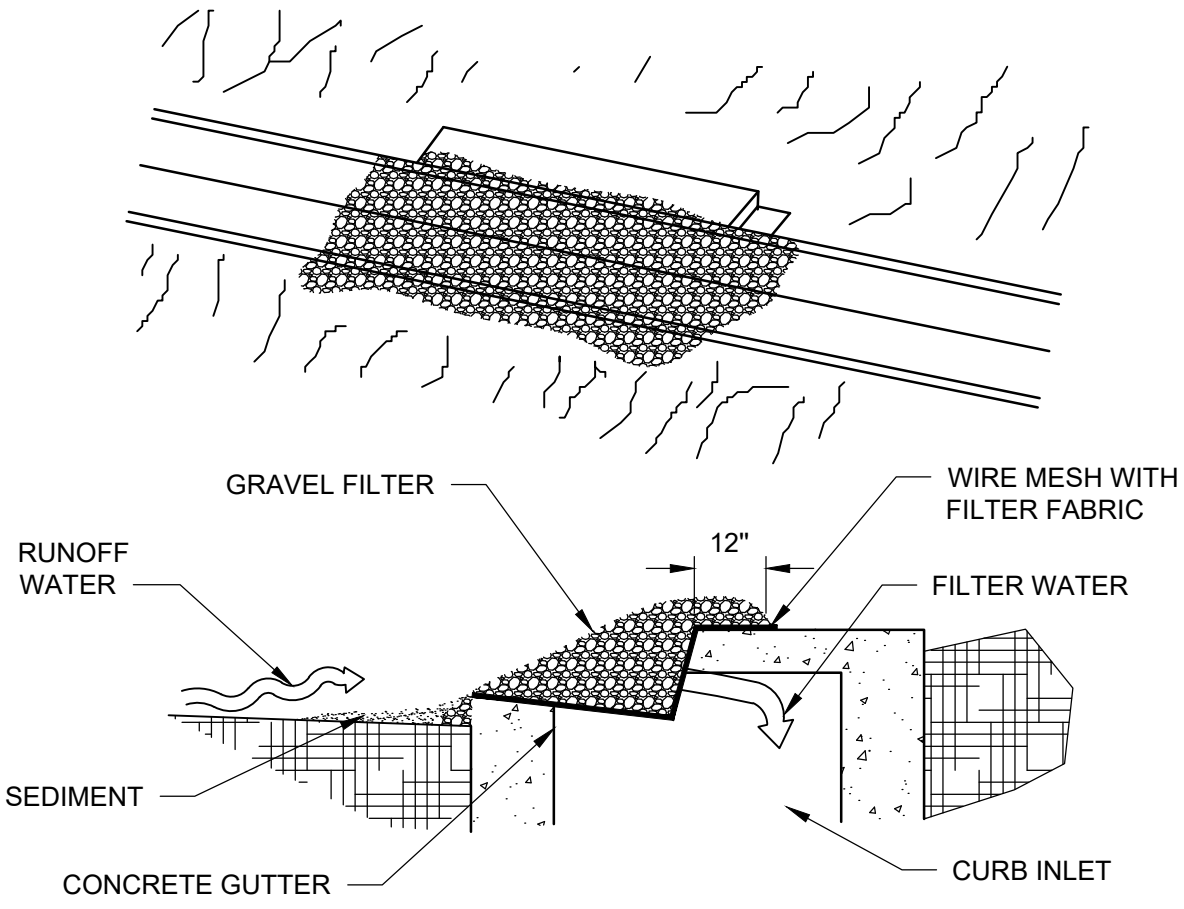

SPECIFIC APPLICATION:
 THIS METHOD OF INLET PROTECTION IS APPLICABLE AT CURB INLETS WHERE PONDING IN FRONT OF THE STRUCTURE IS NOT LIKELY TO CAUSE INCONVENIENCE OR DAMAGE TO ADJACENT STRUCTURES AND UNPROTECTED AREAS.

GRAVEL CURB INLET SEDIMENT FILTER

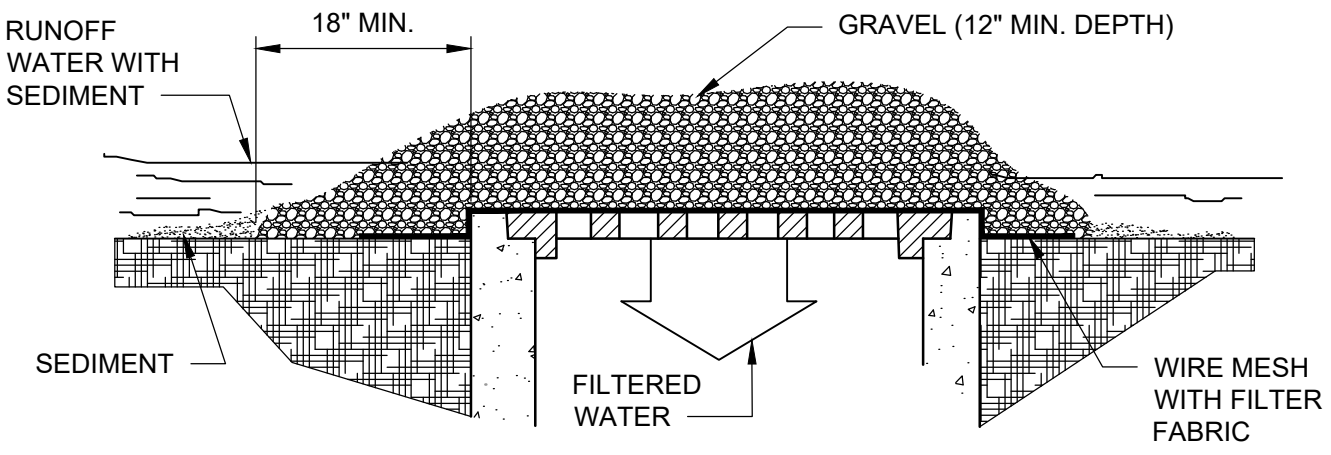

SPECIFIC APPLICATION:
 THIS METHOD OF INLET PROTECTION IS APPLICABLE WHERE HEAVY CONCENTRATED FLOWS ARE EXPECTED, BUT NOT WHERE PONDING AROUND THE STRUCTURE MIGHT CAUSE EXCESSIVE INCONVENIENCE OR DAMAGE TO ADJACENT STRUCTURES AND UNPROTECTED AREAS.

GRAVEL AND WIRE MESH DROP INLET SEDIMENT FILTER

GRAVEL INLET SEDIMENT TRAP	CITY OF JACKSONVILLE STANDARD	N.T.S.	PLATE D-903
		DATE DRAWN	8-4-79
		REVISED DATE	11-21-24

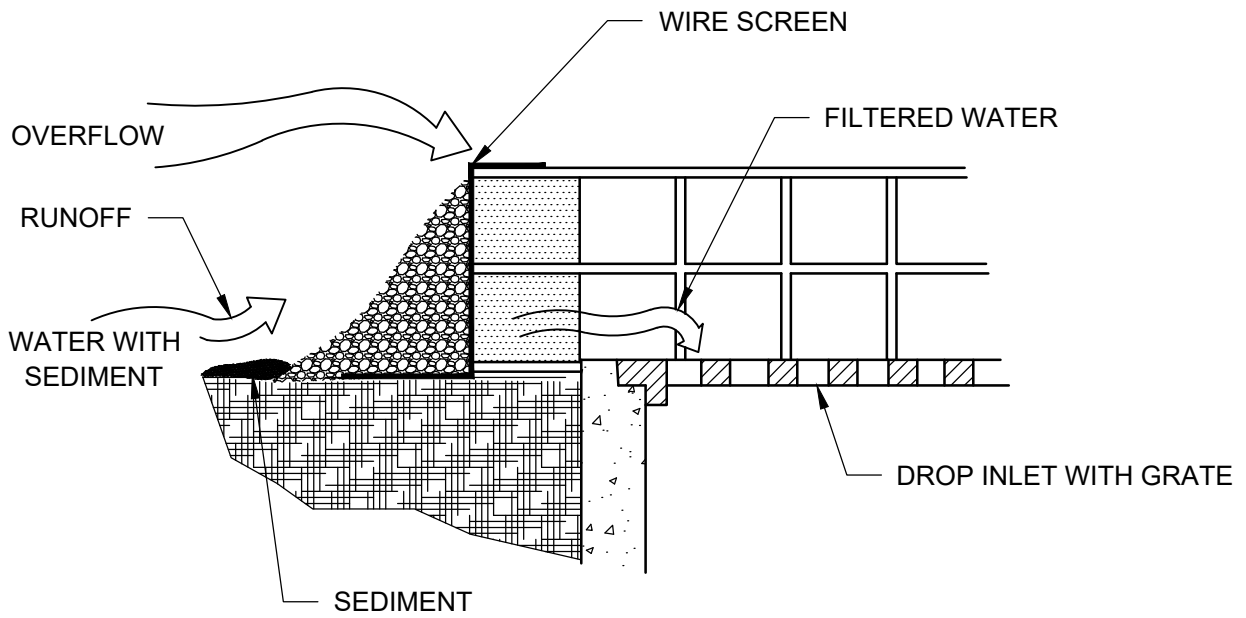
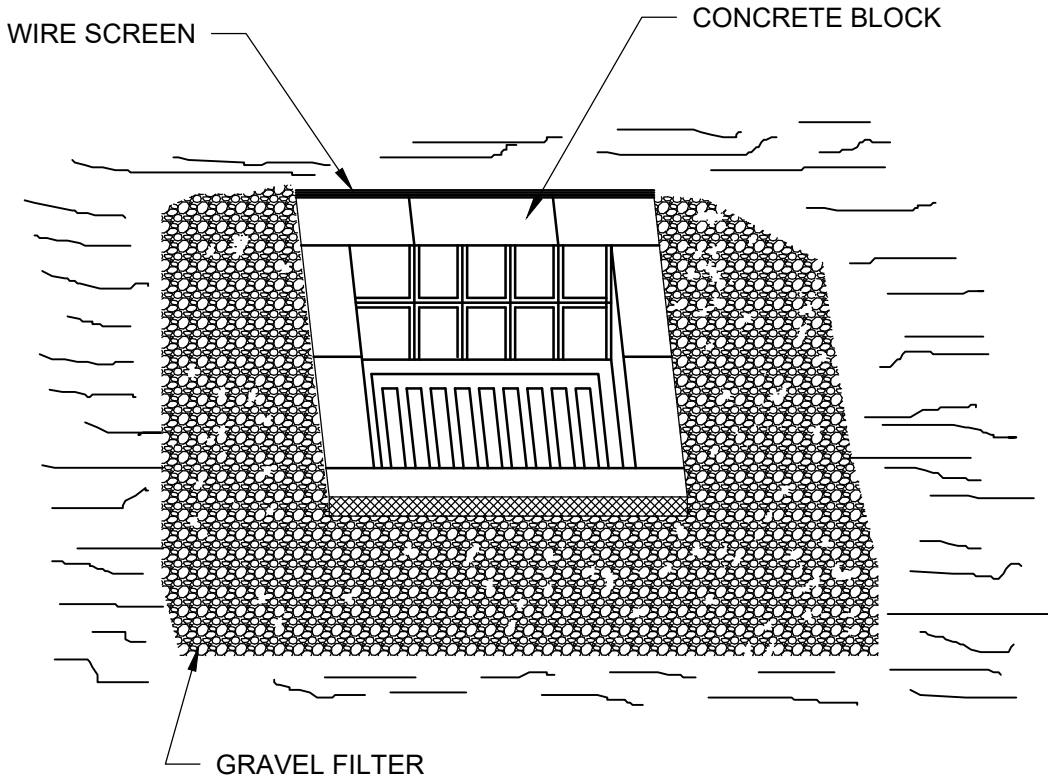

SPECIFIC APPLICATION :
 THIS METHOD OF INLET PROTECTION IS APPLICABLE WHERE HEAVY FLOWS ARE EXPECTED AND WHERE AN OVERFLOW CAPACITY IS NECESSARY TO PREVENT EXCESSIVE PONDING AROUND THE STRUCTURE.

BLOCK AND GRAVEL DROP INLET SEDIMENT FILTER	CITY OF JACKSONVILLE STANDARD		N.T.S.	PLATE D-904
			DATE DRAWN 8-4-79	
			REVISED DATE 11-21-24	

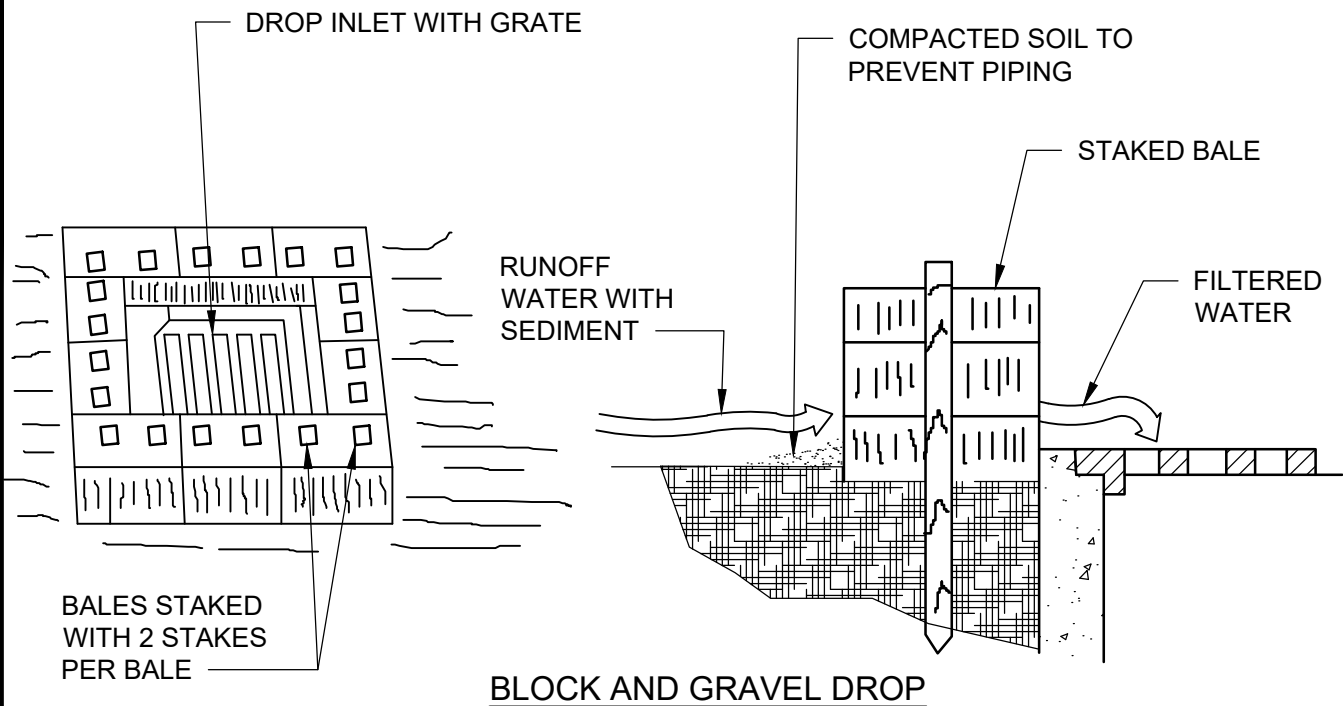

SPECIFIC APPLICATION :

THIS METHOD OF INLET PROTECTION IS APPLICABLE WHERE THE INLET DRAINS A RELATIVELY FLAT AREA (SLOPES NO GREATER THAN 5 PERCENT) WHERE SHEET OR OVERLAND FLOWS (NOT EXCEEDING 0.5 cfs) ARE TYPICAL. THE METHOD SHALL NOT APPLY TO INLETS RECEIVING CONCENTRATED FLOWS, SUCH AS IN STREET OR HIGHWAY MEDIANS.

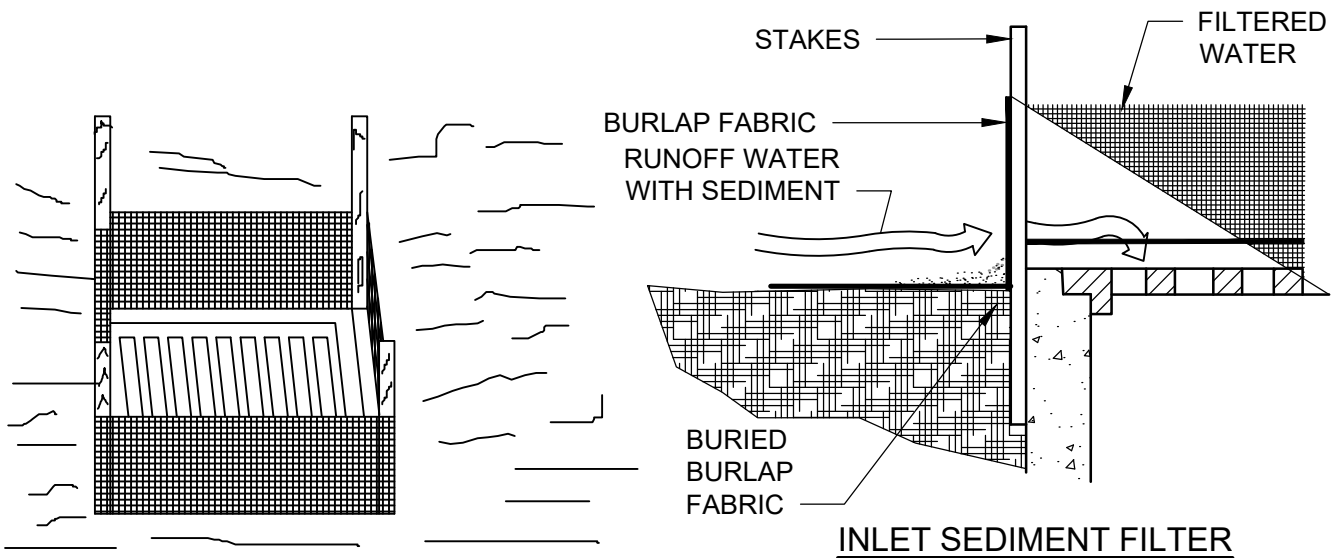

SPECIFIC APPLICATION:

THIS METHOD OF INLET PROTECTION IS APPLICABLE WHERE THE INLET DRAINS A RELATIVELY FLAT AREA (SLOPES NO GREATER THAN 5 PERCENT) WHERE SHEET OR OVERLAND FLOWS (NOT EXCEEDING 0.5 cfs) ARE TYPICAL. THE METHOD SHALL NOT APPLY TO INLETS RECEIVING CONCENTRATED FLOWS. SUCH AS IN STREET OR HIGHWAY MEDIANS.

DROP INLET SEDIMENT FILTER	CITY OF JACKSONVILLE STANDARD	N.T.S.	PLATE D-905
		DATE DRAWN	8-5-79
		REVISED DATE	11-21-24

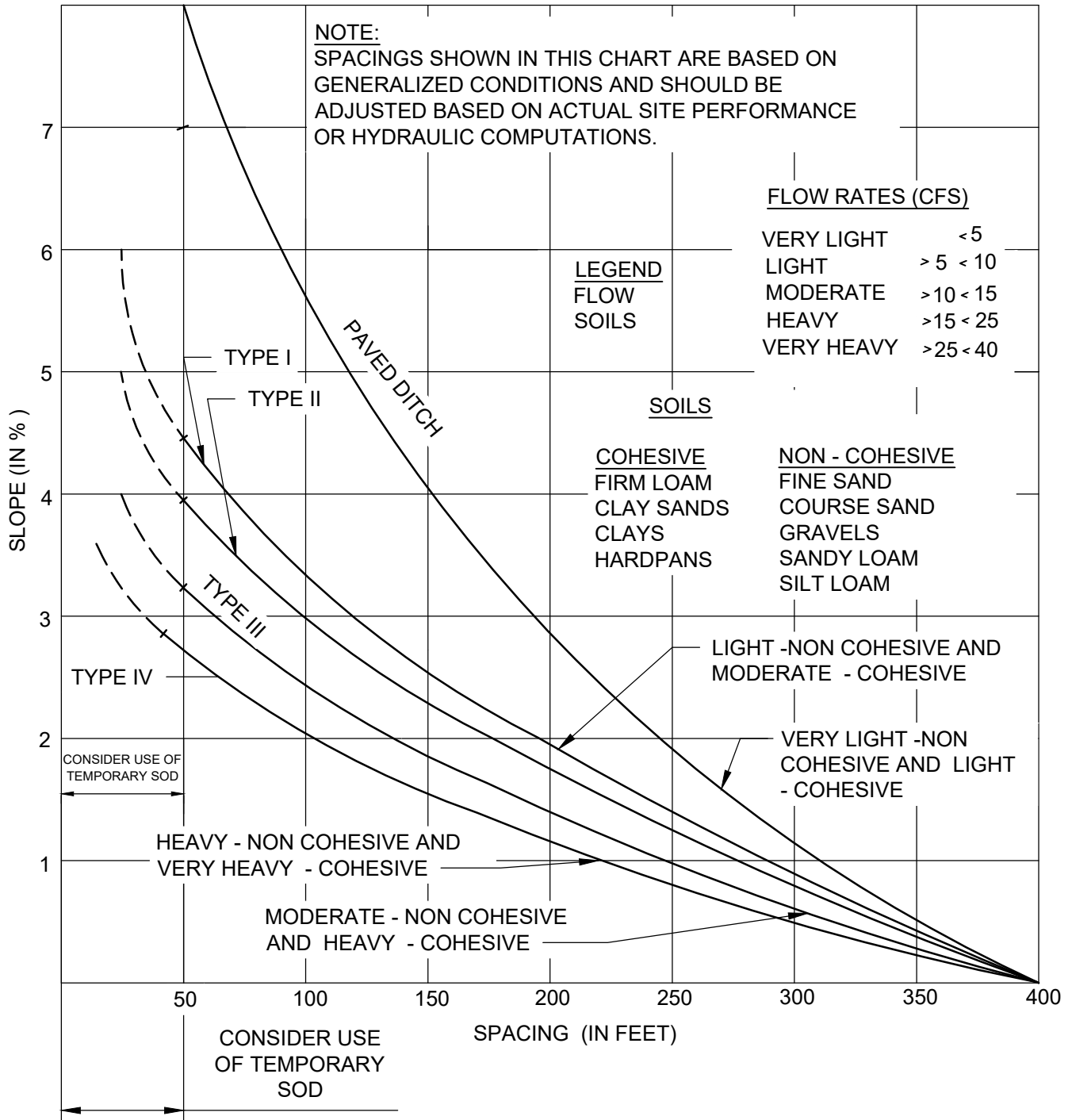
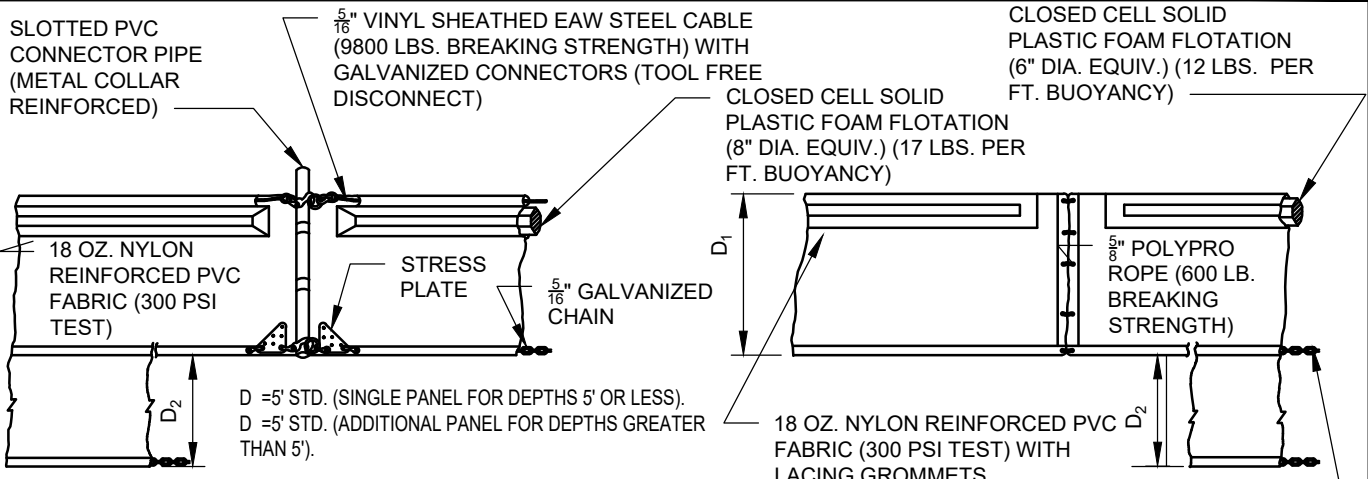

CHART I

RECOMMENDED SPACING FOR TYPE III AND TYPE IV SILT FENCES

SPACING RECOMMENDATION FOR SILT FENCES	CITY OF JACKSONVILLE STANDARD	N.T.S.	PLATE D-906
		DATE DRAWN	8-9-79
		REVISED DATE	11-21-24



CURTAIN TO REACH BOTTOM UP TO DEPTHS OF 10'. TWO (2) PANELS TO BE USED FOR DEPTHS GREATER THAN 10' UNLESS SPECIAL DEPTHS SPECIFICALLY CALLED FOR IN THE PLANS OR AS DETERMINED BY THE ENGINEER.

TYPE II

TYPE I

FLOATING TURBIDITY BARRIERS

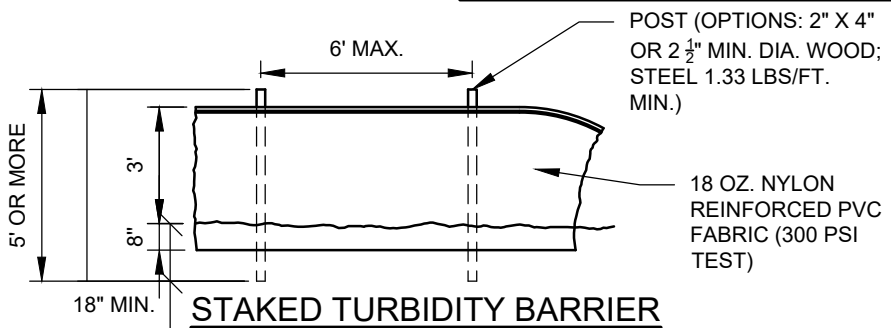

LEGEND

- PILE LOCATIONS
- ▨ DREDGE OR FILL AREA
- MOORING BUOY W/ANCHOR
- ANCHOR
- BARRIER MOVEMENT DUE TO CURRENT ACTION

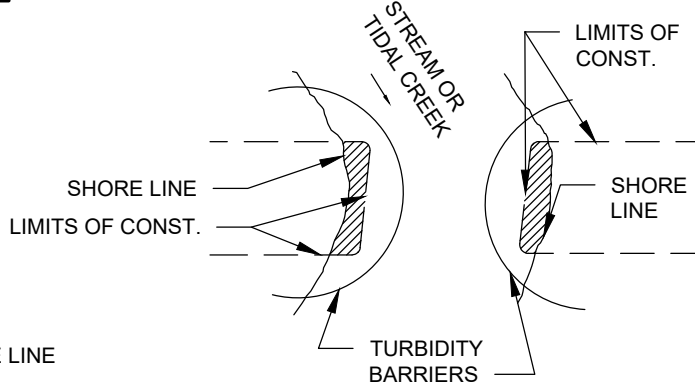
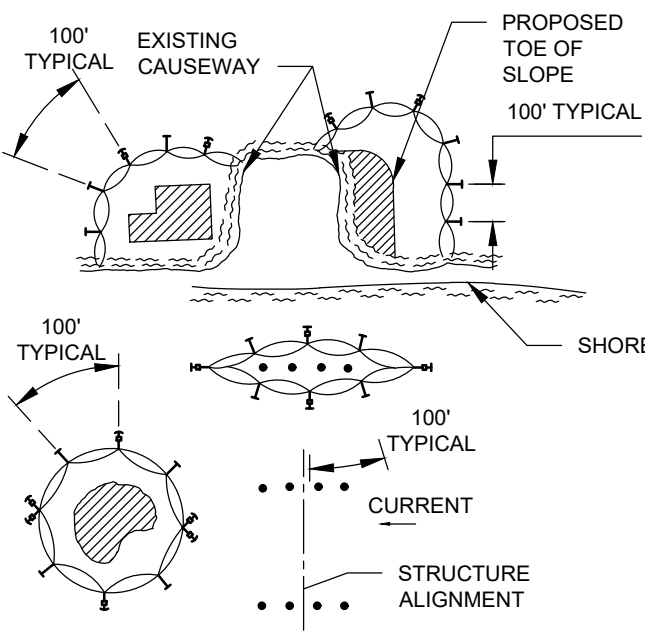

NOTE:
TURBIDITY BARRIERS FOR FLOWING STREAMS AND TIDAL CREEKS MAY BE EITHER FLOATING, OR STAKED TYPES OR ANY COMBINATIONS OF TYPES THAT WILL SUIT SITE CONDITIONS AND MEET EROSION CONTROL AND WATER QUALITY REQUIREMENTS. THE BARRIER TYPE(S) WILL BE AT THE CONTRACTORS OPTION UNLESS OTHERWISE SPECIFIED IN THE PLANS, HOWEVER PAYMENT WILL BE UNDER THE PAY ITEM(S) ESTABLISHED IN THE PLANS FOR FLOATING TURBIDITY BARRIER AND/OR STAKED TURBIDITY BARRIER. POSTS IN STAKED TURBIDITY BARRIERS TO BE INSTALLED IN VERTICAL POSITION UNLESS OTHERWISE DIRECTED BY THE ENGINEER.

NOTES:

1. TURBIDITY BARRIERS ARE TO BE USED IN ALL PERMANENT BODIES OF WATER REGARDLESS OF WATER DEPTH.
2. NUMBER AND SPACING OF ANCHORS DEPENDENT ON CURRENT VELOCITIES.
3. DEPLOYMENT OF BARRIER AROUND PILE LOCATIONS MAY VARY TO ACCOMMODATE CONSTRUCTION OPERATIONS.
4. NAVIGATION MAY REQUIRE SEGMENTING BARRIER DURING CONSTRUCTION OPERATIONS.

TURBIDITY BARRIER APPLICATIONS

TURBIDITY BARRIERS	CITY OF JACKSONVILLE STANDARD	N.T.S.	PLATE D-907
		DATE DRAWN	08-09-93
		REVISED DATE	11-21-24

POST (OPTIONS: 2" X 4" OR WOOD; STEEL 2 1/2" MIN. DIA. 1.33 LBS/FT. MIN.)

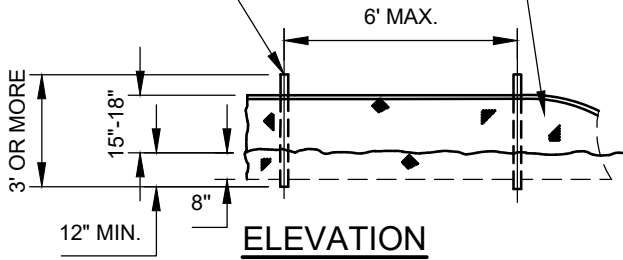

ELEVATION

FILTER FABRIC (IN CONFORMANCE WITH SEC. 985 FDOT SPEC.)

PRINCIPLE POST POSITION (CANTED 20° TOWARD FLOW)

OPTIONAL POST POSITIONS

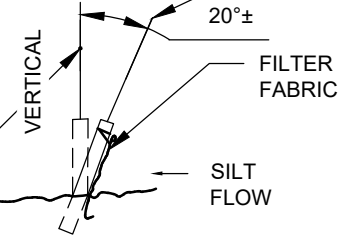

SECTION

TYPE III SILT FENCE

POST (OPTIONS: 4" X 4" WOOD OR 3" MIN. DIA. STEEL 1.33 LBS/FT. MIN.)

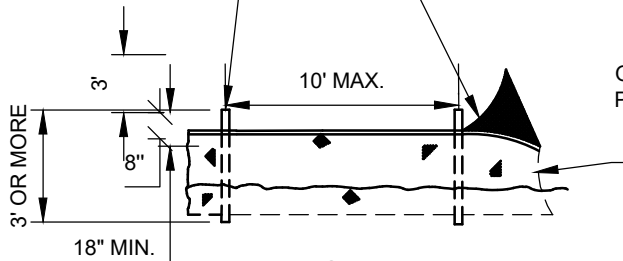

ELEVATION

POULTRY MESH (20. GA. MIN.) OR TYPE A FENCE FABRIC (INDEX NO. 452 & SEC. 985 FDOT SPEC.)

OPTIONAL POST POSITIONS

PRINCIPLE POST POSITION (CANTED 20° TOWARD FLOW)

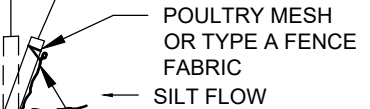

SECTION

FILTER FABRIC (IN CONFORMANCE WITH SEC. 985 FDOT SPEC.)

FILTER FABRIC

NOTE: SILT FENCE TO BE PAID FOR UNDER THE CONTRACT UNIT PRICE FOR STAKED SILT FENCE (LF).

TYPE IV SILT FENCE

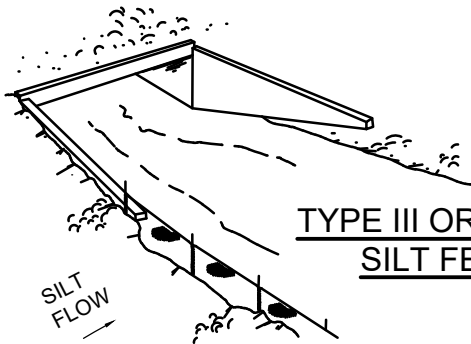

TYPE III OR TYPE IV SILT FENCE

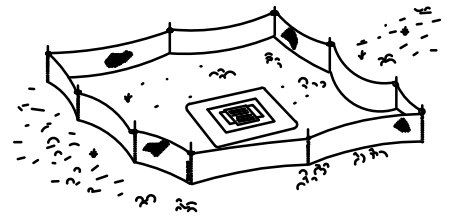

TYPE III OR TYPE IV SILT FENCE PROTECTION AROUND DITCH BOTTOM INLETS.

DO NOT DEPLOY IN A MANNER THAT SILT FENCES WILL ACT AS A DAM ACROSS PERMANENT FLOWING WATERCOURSES. SILT FENCES ARE TO BE USED AT UPLAND LOCATIONS AND TURBIDITY BARRIERS USED AT PERMANENT BODIES OF WATER.

SILT FENCE APPLICATIONS



TYPE IV SILT FENCE



TYPE III SILT FENCE

NOTE: SPACING FOR TYPE III FENCE TO BE IN ACCORDANCE WITH CHART I, PLATE D-906 AND DITCH INSTALLATIONS AT DRAINAGE STRUCTURES ABOVE.

SILT FENCE TYPE III & IV	CITY OF JACKSONVILLE STANDARD	N.T.S.	PLATE D-908
		DATE DRAWN	8-9-93
		REVISED DATE	11-21-24

1. SET POSTS AND EXCAVATE A 4"x4" TRENCH UPSLOPE ALONG THE LINE OF POSTS

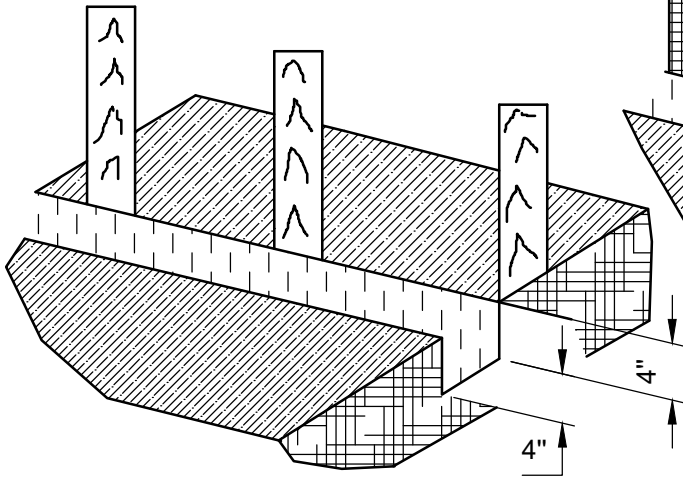

2. STAPLE WIRE FENCING TO THE POSTS.

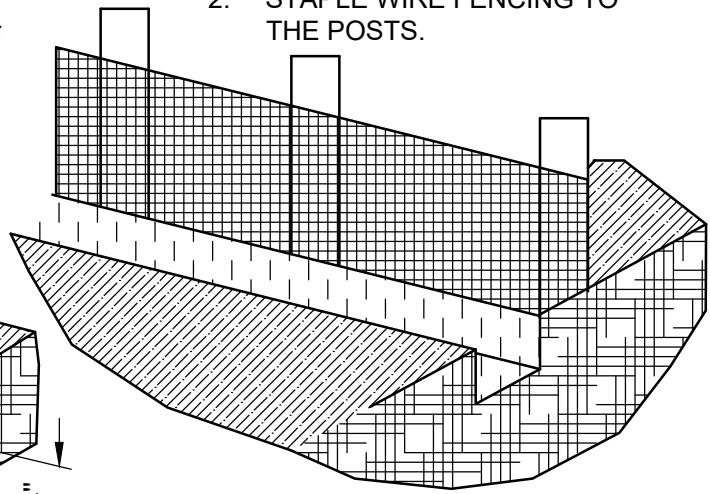

3. ATTACH THE FILTER FABRIC TO THE WIRE FENCE AND EXTEND IT INTO THE TRENCH.

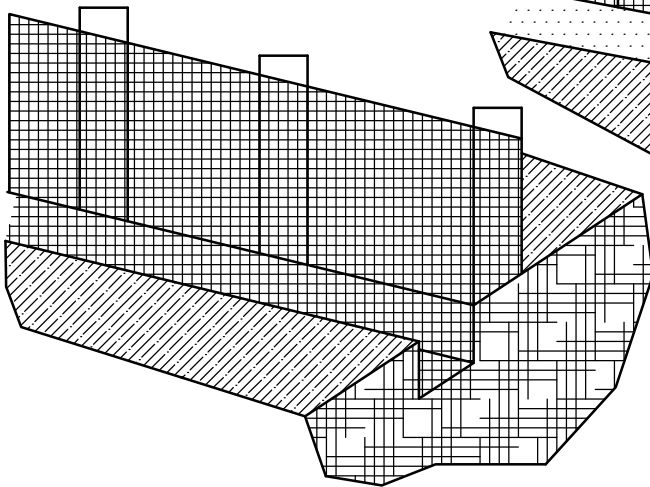

4. BACKFILL AND COMPACT THE EXCAVATED SOIL.

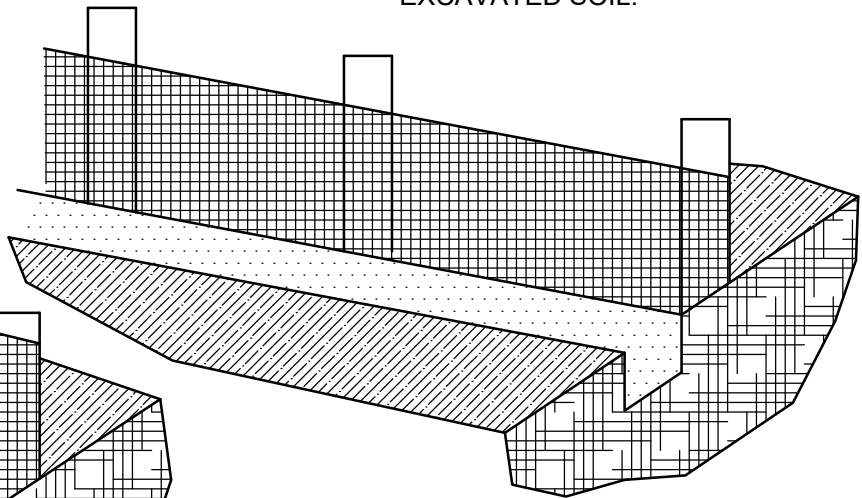

EXTENSION OF FABRIC AND WIRE INTO THE TRENCH.

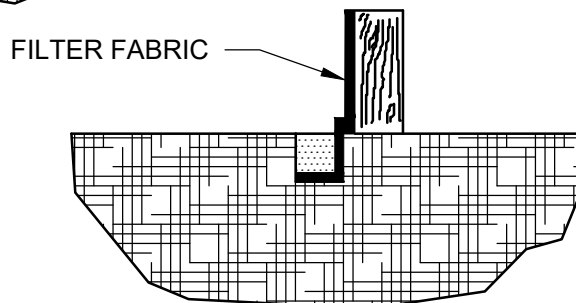

CONSTRUCTION DETAILS
FOR SILT FENCES

CITY OF
JACKSONVILLE
STANDARD

N.T.S.

PLATE D-909

DATE DRAWN 08-05-93

REVISED DATE 11-21-24

1. SET THE STAKES.

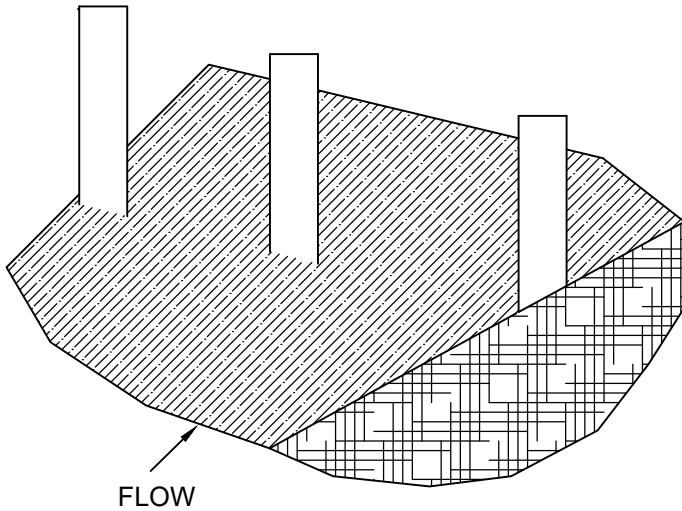

2. EXCAVATE A 4"x4" TRENCH UPSLOPE ALONG THE LINE OF STAKES.

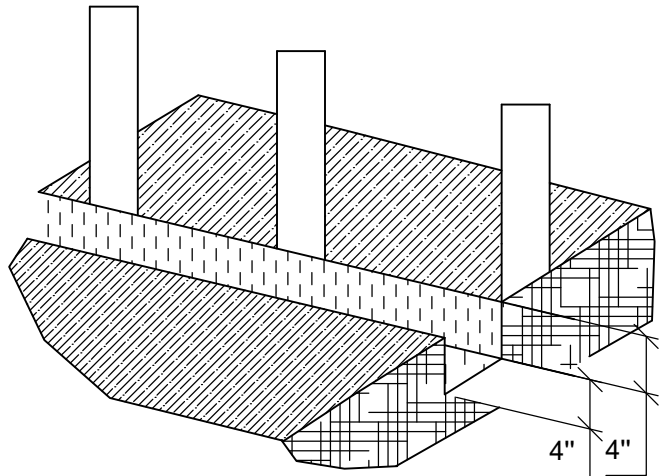

3. STAPLE FILTER MATERIAL TO STAKES AND EXTEND IT INTO THE TRENCH.

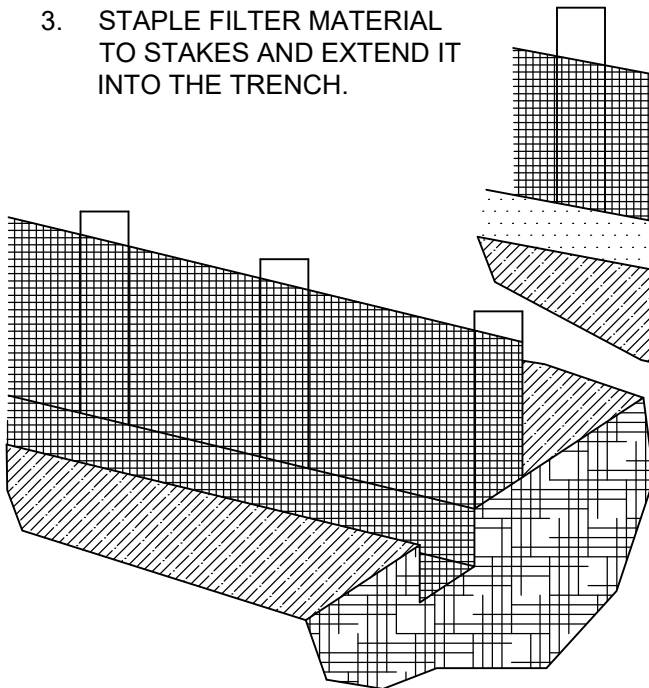

4. BACKFILL AND COMPACT THE EXCAVATED SOIL.

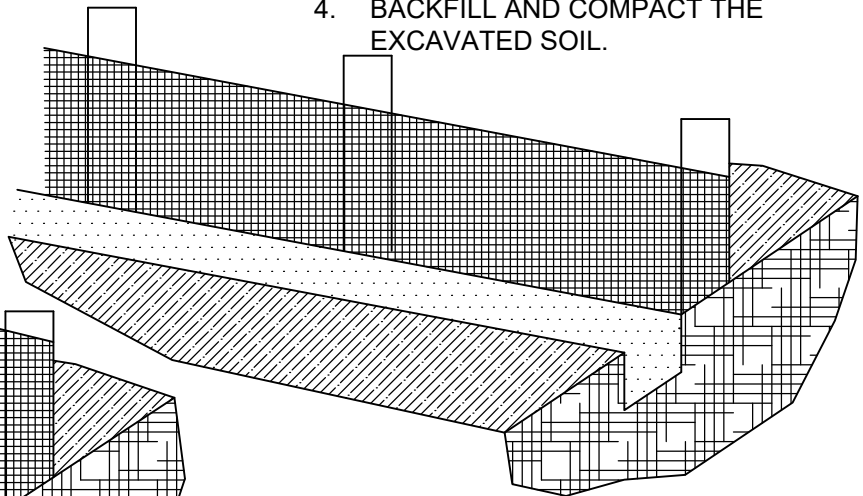

CONSTRUCTION OF A FILTER BARRIER

PLAN

ELEVATION

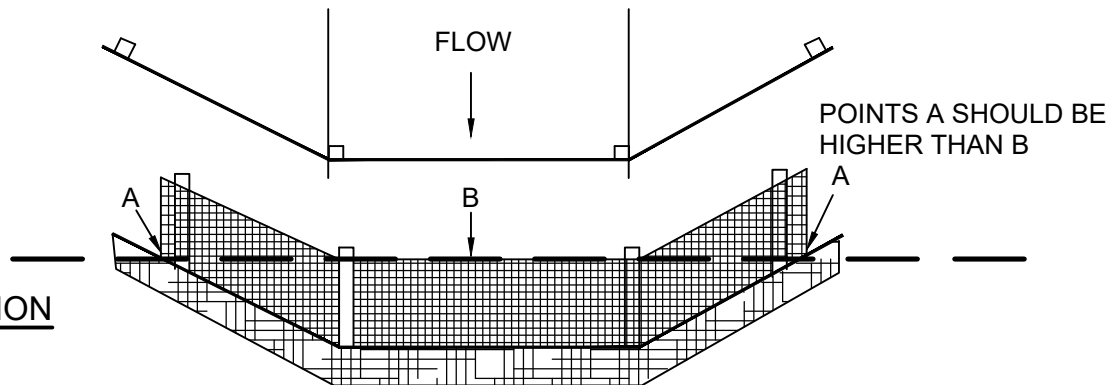

PROPER PLACEMENT OF A FILTER BARRIER IN A DRAINAGE WAY

FILTER BARRIER
CONSTRUCTION DETAIL

CITY OF
JACKSONVILLE
STANDARD

N.T.S.

PLATE D-910

DATE DRAWN 08-05-93

REVISED DATE 11-21-24

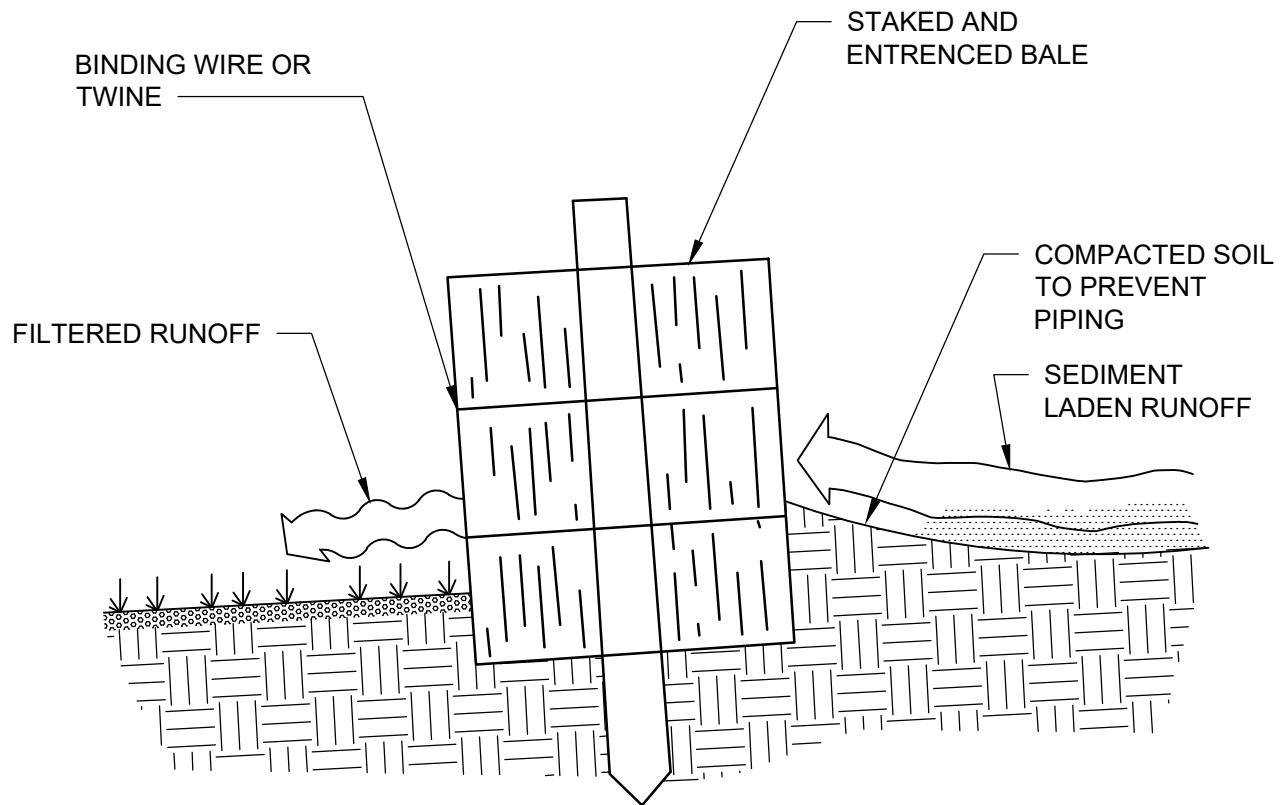

CROSS-SECTION OF A PROPERLY INSTALLED BALE

STAKED BALE	CITY OF JACKSONVILLE STANDARD	N.T.S.	PLATE D-911
		DATE DRAWN 05-07-90	
		REVISED DATE 5-12-94	

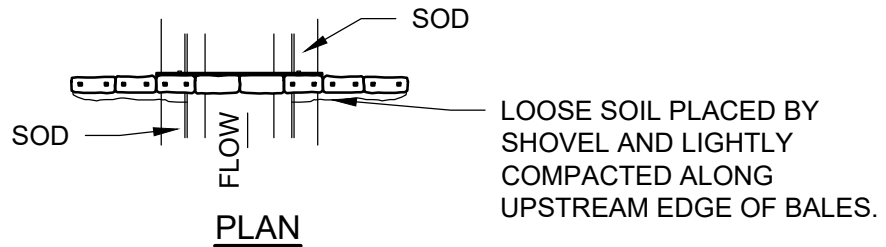

ANCHOR BALES WITH 2 - 2" X 2" X 4' STAKES PER BALE.

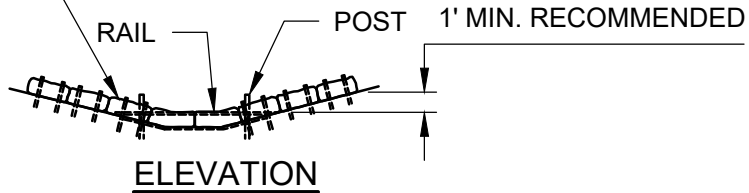

SPACING: BALE BARRIERS FOR PAVED DITCHES SHOULD BE SPACED IN ACCORDANCE WITH CHART I, SHEET 1 OF 3, INDEX NO. 102

BARRIER FOR PAVED DITCH

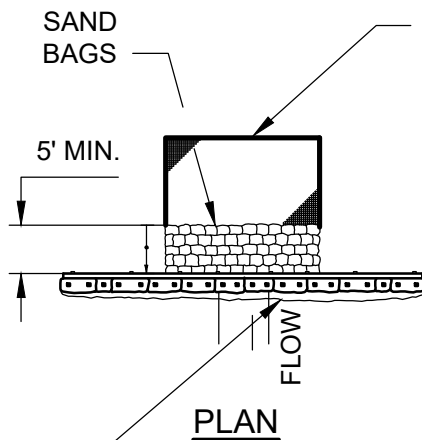

WOVEN FILTER FABRIC IN ABSENCE OF ESTABLISHED GRASS (APPROX. 12' X 12'). SECURE EDGES BY ENTRENCHING AND EXTEND UNDER BAGS AND BALES. FABRIC SHALL MEET THE REQUIREMENTS OF SECTION 985 OF THE STANDARD SPECIFICATIONS. COST OF FABRIC TO BE INCLUDED IN THE CONTRACT UNIT PRICE FOR BALES, TN.

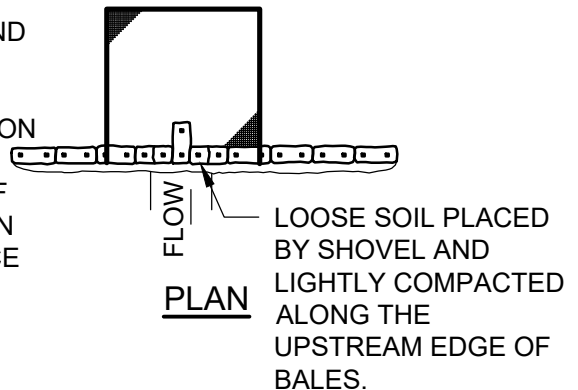

LOOSE SOIL PLACED BY SHOVEL AND LIGHTLY COMPACTED ALONG THE UPSTREAM EDGE OF BALES.

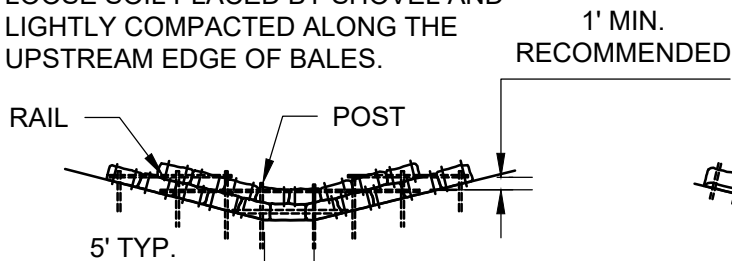

ANCHOR LOWER BALES WITH 2 - 2" X 2" X 4' STAKES PER BALE. ANCHOR TOP BALES TO LOWER BALES WITH 2 - 2" X 2" X 4' STAKES PER BALE.

TYPE II

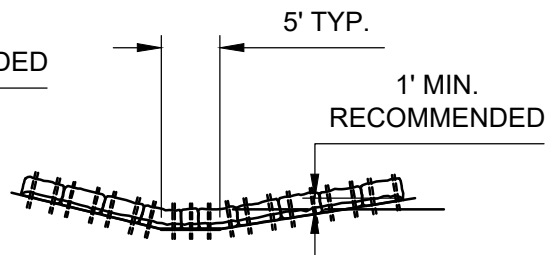

ANCHOR BALES WITH 2 - 2" X 2" X 4' STAKES PER BALE

TYPE I

APPLICATION AND SPACING: THE USE OF TYPES I & II BALE BARRIERS SHOULD BE LIMITED TO THE CONDITIONS OUTLINED IN CHART I, SHEET 1 OF 3, INDEX NO. 102 (F.D.O.T.)

BARRIER FOR UNPAVED DITCHES

BALE BARRIERS TYPE I & II	CITY OF JACKSONVILLE STANDARD	N.T.S.	PLATE D-912
		DATE DRAWN	08-09-93
		REVISED DATE	5-12-94

1. EXCAVATE THE TRENCH.

2. PLACE AND STAKE BALES.

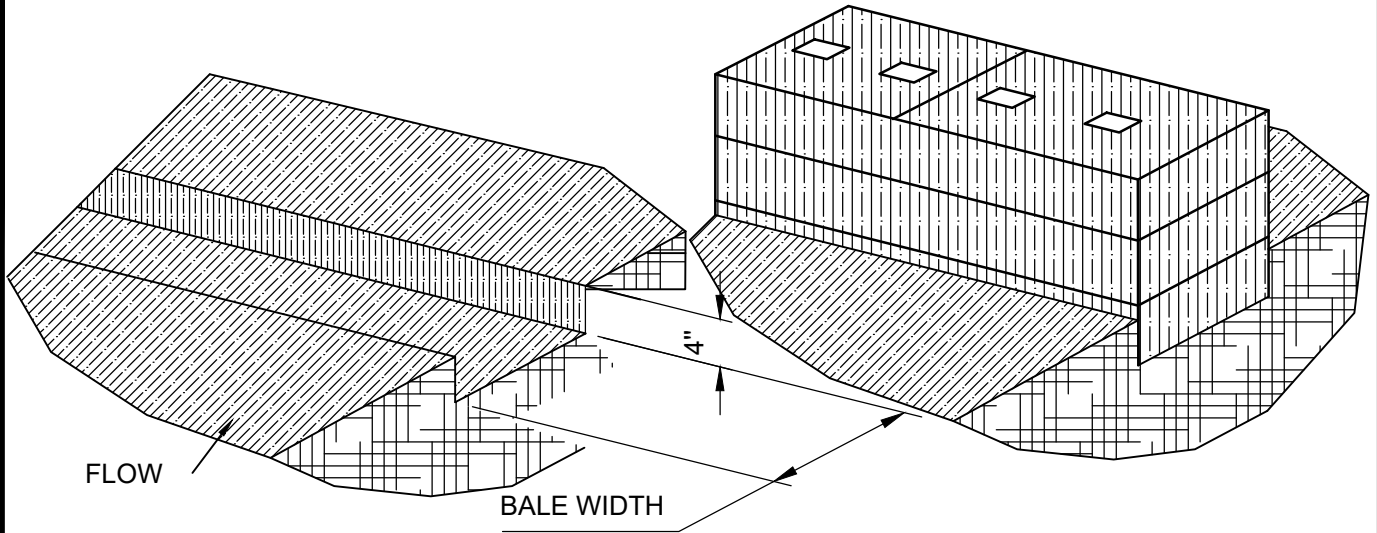

3. WEDGE LOOSE MATERIAL BETWEEN BALES.

4. BACKFILL AND COMPACT THE EXCAVATED SOIL.

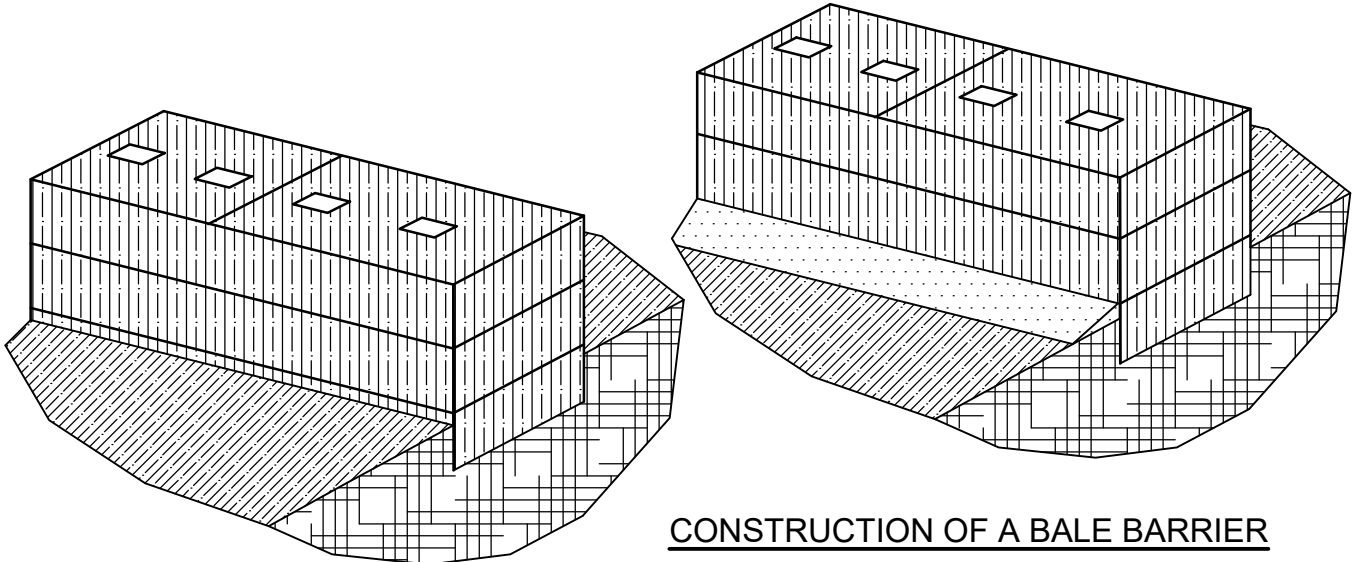

CONSTRUCTION OF A BALE BARRIER

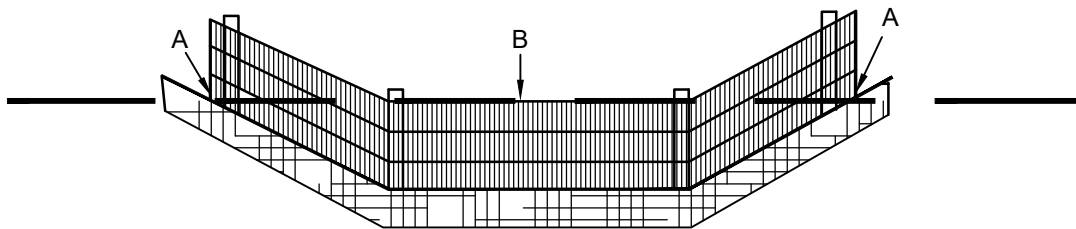

POINTS A SHOULD BE HIGHER THAN POINT B

PROPER PLACEMENT OF BALE BARRIER IN DRAINAGE WAY

BALE BARRIER
CONSTRUCTION DETAILS

CITY OF
JACKSONVILLE
STANDARD

N.T.S.

PLATE D-913

DATE DRAWN 08/05/93

REVISED DATE 5-12-93

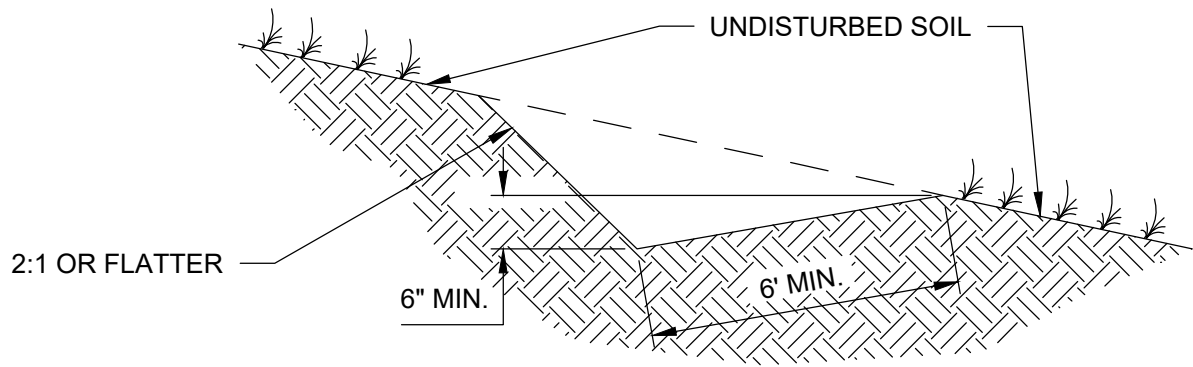

SECTION A-A

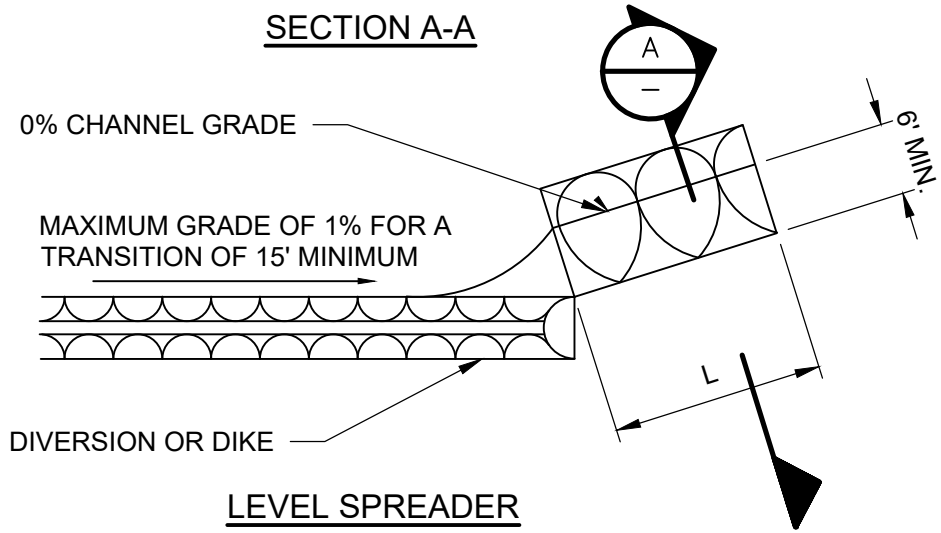

LEVEL SPREADER

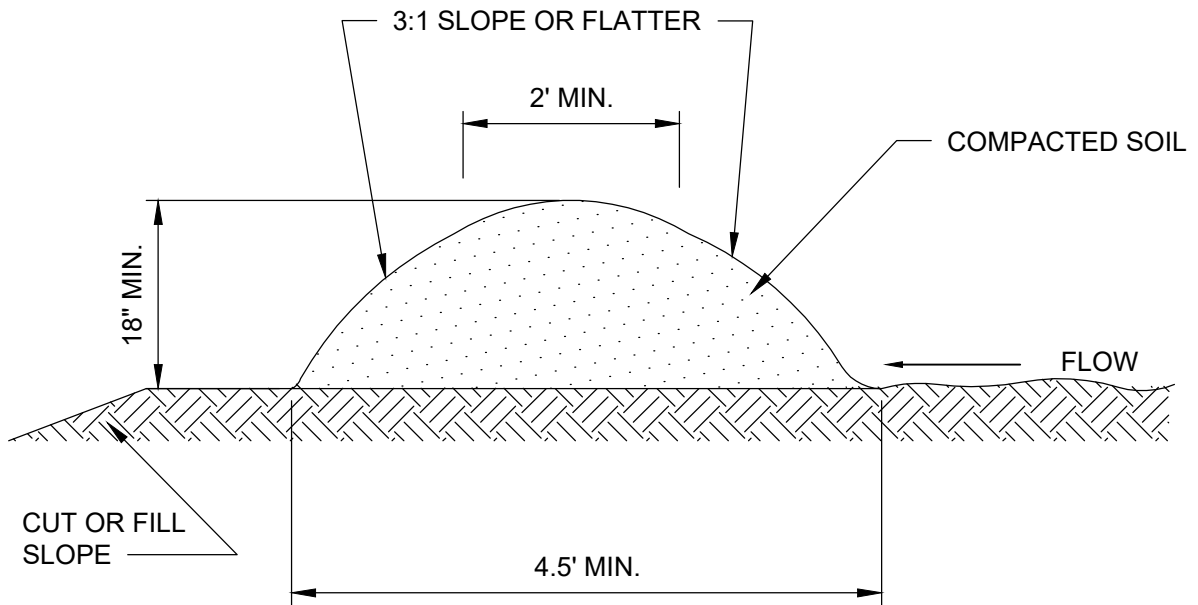

TEMPORARY DIVERSION DIKE

DIVERSION DIKE	CITY OF JACKSONVILLE STANDARD	N.T.S.	PLATE D-914
		DATE DRAWN	05-09-90
		REVISED DATE	11-21-24

COMMON NAME (BOTANICAL NAME)	SEEDING RATE		PLANTING DATES	COMMENTS
	ACRE	1000 FT2		
OATS (<i>Avena sativa</i>)	3 Bu (125 lbs)	3 lbs	N. FLA. SEPTEMBER- FEBRUARY	WILL NOT TOLERATE FLOODING, HIGH WATER TABLE SOILS.
RYE (<i>Secale cereale</i>)	3 Bu (170 lbs)	4 lbs	SEPTEMBER- FEBRUARY	TOLERATES COLD AND DROUGHT.
WHEAT (<i>Triticum</i> sp)	3 Bu (120 lbs)	3 lbs	SEPTEMBER- FEBRUARY	VOLUNTEERS MAY RETURN.
ANNUAL RYEGRASS (<i>Lolium multiflorum</i>)	60 lbs	1.5 lbs	SEPTEMBER- FEBRUARY	ANNUAL WINTER LEGUME. INOCULATE SEED AT 5 TIMES RECOMMENDED RATE. DOES POORLY ON DEEP DRY SANDS. WILL NOT TOLERATE FLOODING.
CRIMSON CLOVER (<i>Trifolium incarnatum</i>)	25 lbs	9 oz	SEPTEMBER- NOVEMBER	ANNUAL WINTER LEGUME. INOCULATE SEED AT 5 TIMES RECOMMENDED RATE. GROWS BEST ON MOIST SOILS. WILL NOT TOLERATE FLOODING. EASILY HURT BY DROUGHT.
RED CLOVER (<i>Trifolium pratense</i>)	15 lbs	6 oz	SEPTEMBER- DECEMBER	ANNUAL WINTER LEGUME. INOCULATE SEED AT 5 TIMES RECOMMENDED RATE. GROWS BEST ON MOIST-WET SOILS, TOLERATES SOME FLOODING.
WHITE CLOVER (<i>Trifolium repens</i>)	6 lbs	2.5 oz	SEPTEMBER- DECEMBER	ANNUAL WINTER LEGUME. INOCULATE SEED AT 3-5 TIMES RECOMMENDED RATE. GROWS WELL ON BOTH FLATWOODS AND UPLAND SOILS. WILL NOT TOLERATE FLOODING.
ANNUAL SWEETCLOVER (<i>Melilotus altissima</i>)	15 lbs	6 oz	SEPTEMBER- DECEMBER	ANNUAL WINTER LEGUME. INOCULATE SEED AT 3-5 TIMES RECOMMENDED RATE. GROWS ON SOIL TOO WET FOR CRIMSON. TOLERATES SOME FLOODING. USE SCARIFIED SEED.
ARROWLEAF CLOVER (<i>Trifolium vesiculosum</i>)	15 lbs	6 oz	SEPTEMBER- DECEMBER	ANNUAL WINTER LEGUME. INOCULATE SEED AT 3 TIMES RECOMMENDED RATE. SUSCEPTIBLE TO FREEZE DAMAGE AT TIME OF EMERGENCE. USE SCARIFIED SEED.
LUARNE CLOVER (<i>Lupinus</i> sp.)	60 lbs	1.5 lbs	SEPTEMBER- DECEMBER	SHORT LIVED PERENNIAL. SOME DROUGHT RESISTANCE. GROWS BEST ON WELL-DRAINED, FERTILE SOILS. WILL NOT TOLERATE WET SOILS.
ALFALFA (<i>Medicago sativa</i>)	22 lbs	8 oz	SEPTEMBER- DECEMBER	GROWS BEST ON WELL-DRAINED, LOAMY SOILS.
AUSTRIAN WINTER PEAS	45 lbs	1 lb	SEPTEMBER- DECEMBER	WARM SEASON ANNUAL LEGUME. GROWS BEST ON SANDY LOAMS. FAIRLY DROUGHT RESISTANT.
HAIRY VETCH (<i>Vicia villosa</i>)	25 lbs	9 oz	SEPTEMBER- DECEMBER	
ALYCECLOVER (<i>Alysicarpus vaginalis</i>)	15 lbs	6 oz	APRIL- JULY	
COMMON LESPEDEZA (<i>Lespedeza striata</i>)	30 lbs	11 oz	MARCH- JULY	
HAIRY INDIGO (<i>Indigofera tinctoria</i>)	8 lbs (120 ls)	3 oz	MARCH- JULY	
JOINT VETCH (<i>Aeschynomera americana</i>)	8 lbs	3 oz	MARCH- AUGUST	WARM SEASON ANNUAL LEGUME. MOST SUITABLE OF SUMMER LEGUMES FOR USE IN LOW, WET AREAS.
MILLET (<i>Setaria</i> sp)	30 lbs	11 oz	MARCH- AUGUST	WARM SEASON ANNUAL. DOES NOT TOLERATE FLOODING. GROWS BEST IN FERTILE, MOIST SOILS. PEARL AND BROWNTOP ARE GOOD VARIETIES TO USE.
SESBANIA (<i>Sesban macrocarpa</i>)	30 lbs	11 oz	MARCH- JULY	WARM SEASON ANNUAL LEGUME. DOES WELL UNDER EXTREMELY WET CONDITIONS.
SORGHAM SUNDANGRASS HYBRID	30 lbs	11 oz	MARCH- JULY	WARM SEASON ANNUAL. RAPID GROWER. TOLERATES DRYER SOILS THAN MILLET. GROWS BEST ON WELL-DRAINED SOILS. CAN ALSO USE SUDANGRASS ALONE.
WEeping LOVEGRASS (<i>Eragrostis curvula</i>)	5 lbs	2 oz	MARCH- AUGUST	SHORT-LIVED PERENNIAL, 2-3 YEARS. TOLERATES HOT, DRY SLOPES AND ACID, INFERTILE SOILS.

USUALLY MIXTURES OF THE ABOVE PLANT MATERIALS ARE BETTER THAN A SINGLE PLANT ALONE. EACH OF THE LEGUMES DISCUSSED ABOVE CAN BE GROWN IN MIXTURE WITH ANNUAL RYEGRASS AND/OR THE SMALL GRAINS. IN A TWO-CROP MIXTURE CUT THE SEEDING RATE OF EACH CROP TO ONE-HALF OF THE RECOMMENDED PLANTING RATE WHEN GROWN ALONE. SIMILARLY THREE PLANT TYPES IN A MIXTURE REQUIRES APPROXIMATELY ONE-THIRD OF THE NORMAL SEEDING RATE FOR EACH PLANT. IN A THREE PLANT MIXTURE CONTAINING A SINGLE LEGUME, THE LEGUME SHOULD BE PLANTED AT ONE-HALF OF THE PURE STAND SEEDING RATE.

PLANT MATERIALS
TEMPORARY SEEDING

CITY OF
JACKSONVILLE
STANDARD

N.T.S.

PLATE D-915

DATE DRAWN 05-08-90

REVISED DATE 11-21-24

SEEDING, MIXTURES, RATES AND DATES

SITE CONDITIONS	SEEDING MIXTURES	SEEDING RATE		SEEDING DATES	COMMENTS
		PER ACRE	PER 1000 FT ²		
HIGH MAINTENANCE LAWNS				N. FLA.	
GENERAL USE	1. BAHIAGRASS 2. BAHIAGRASS BERMUDAGRASS (HULLED) 3. BAHIAGRASS WITH ONE OF THE FOLLOWING: SOUTHERN WHITE CLOVER ANNUAL WHITE SWEETCLOVER CRIMSON CLOVER ARROWLEAF CLOVER ALYCE CLOVER HAIRY INDIGO ASCHYNAMENE	40-60 LBS 40-60 LBS 8-12 LBS 20-30 LBS 3 LBS 8 LBS 12 LBS 8 LBS 8 LBS 3 OZ 4 LBS 12 LBS	1 LB 1 LB 4 OZ .5LB 1.2 OZ 3 OZ 4.5 OZ 3 OZ 3 OZ 3 OZ 1.5 OZ 4.5 OZ	2/15-8/31 2/15-8/15 9/1-1/1 9/1-1/1 9/1-1/1 9/1-1/1 2/15-7/15 2/15-7/15 2/15-7/15	USE 50% SCARIFIED SEED. USE 50% SCARIFIED BAHIA SEED. USE 50% SCARIFIED BAHIA SEED. INNOCULATE LEGUMES.
SLOPES	1. SERICEA LESPEDEZA 2. SERICA LESPEDEZA WITH ONE OF THE FOLLOWING: BAHIAGRASS TALL FESCUE WEEPING LOVEGRASS	A. 40-50 LBS B. 75 LBS 15 LBS 20 LBS 3 LBS	1.2 LBS 1.7 LBS 7 OZ 8 OZ 1.2 OZ	1/1-7/15 7/15-1/1 2/15-8/15 10/1-11/15 2/15-8/15	FOR SCARIFIED SEED. FOR UNHULLED SEED. USE SEEDING RATE SPECIFIED ABOVE. BEST ADAPTED TO N. FLORIDA
DROUGHTY AREAS	1. WEEPING LOVEGRASS 2. WEEPING LOVEGRASS WITH ONE OF THE FOLLOWING: A. BAHIAGRASS (50% SCARIFIED SEED) B. BERMUDAGRASS (HULLED) C. HAIRY PANICUM D. SERICA LESPEDEZA	5 LBS 5 LBS 30-40 LBS 8-12LBS 8-12 LBS	2 OZ 2 OZ 12 OZ 4 OZ 4 OZ	2/15-8/15 2/15-8/15 2/15-8/15 2/15-8/15	GIVES QUICK SUMMER COVER. USE SEEDING RATE AND DATES SPECIFIED ABOVE.

SEEDING MIXTURES,
RATES AND DATES

CITY OF
JACKSONVILLE
STANDARD

N.T.S.

PLATE D-916

DATE DRAWN 05-09-90

REVISED DATE 11-21-24

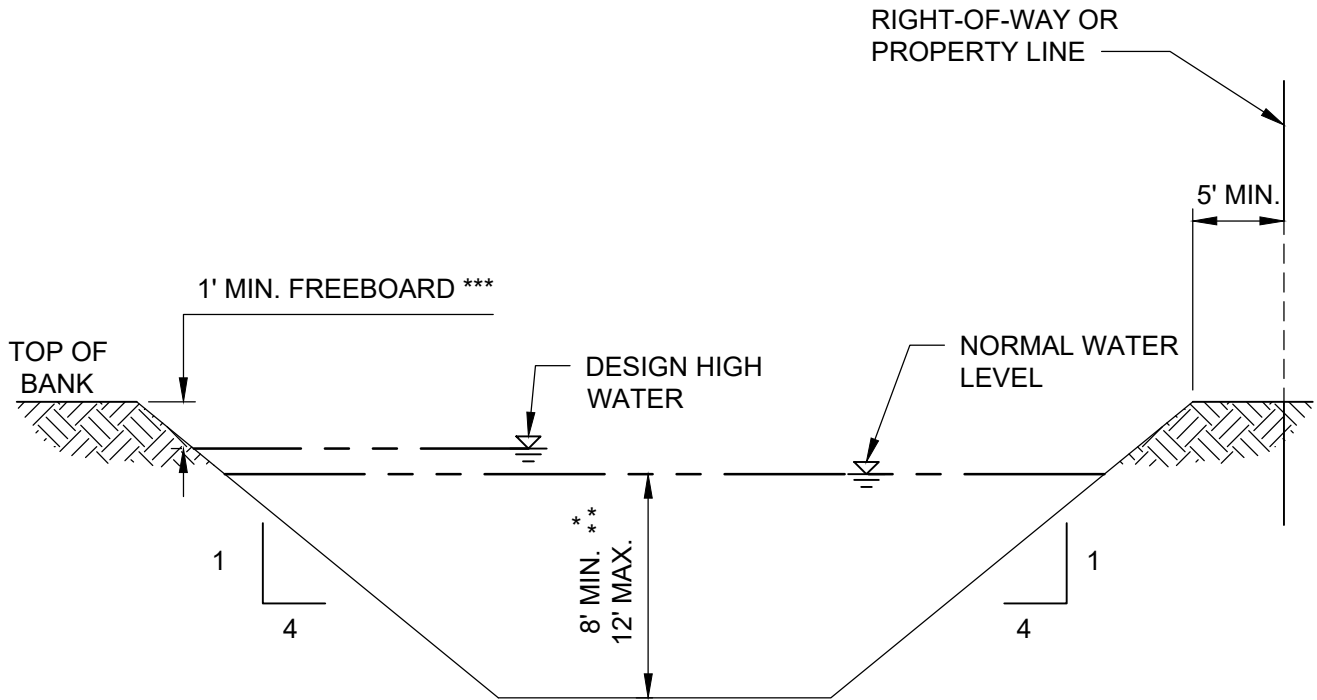

STANDARD DETENTION POND-PREFERRED OPTION

* LESSER DEPTHS ARE ACCEPTABLE IF PUBLIC STORMWATER INFLOWS ARE NOT INVOLVED. THIS ALSO APPLIES TO PLATES D-1003, AND D-1004.

** FOR INTERCONNECTIONS OF DETENTION AREAS WITH PUBLIC STORMWATER INFLOWS, THE INTERCONNECTING PORTIONS MAY BE APPROVED FOR LESSER DEPTH WITH JUSTIFICATION ON A CASE BY CASE BASIS. ABSOLUTE MINIMUM DEPTH WILL BE 4.0 FEET.

*** IF THE BASIN IS CONSTRUCTED HIGHER THAN THE ADJACENT LAND, A 1-FOOT MIN. FREEBOARD IS REQUIRED FOR ALL DESIGN STORMS.

DETENTION POND DETAIL
CASE 1

CITY OF
JACKSONVILLE
STANDARD

N.T.S.

PLATE D-1001

DATE DRAWN 7-20-93

REVISED DATE 11-21-24

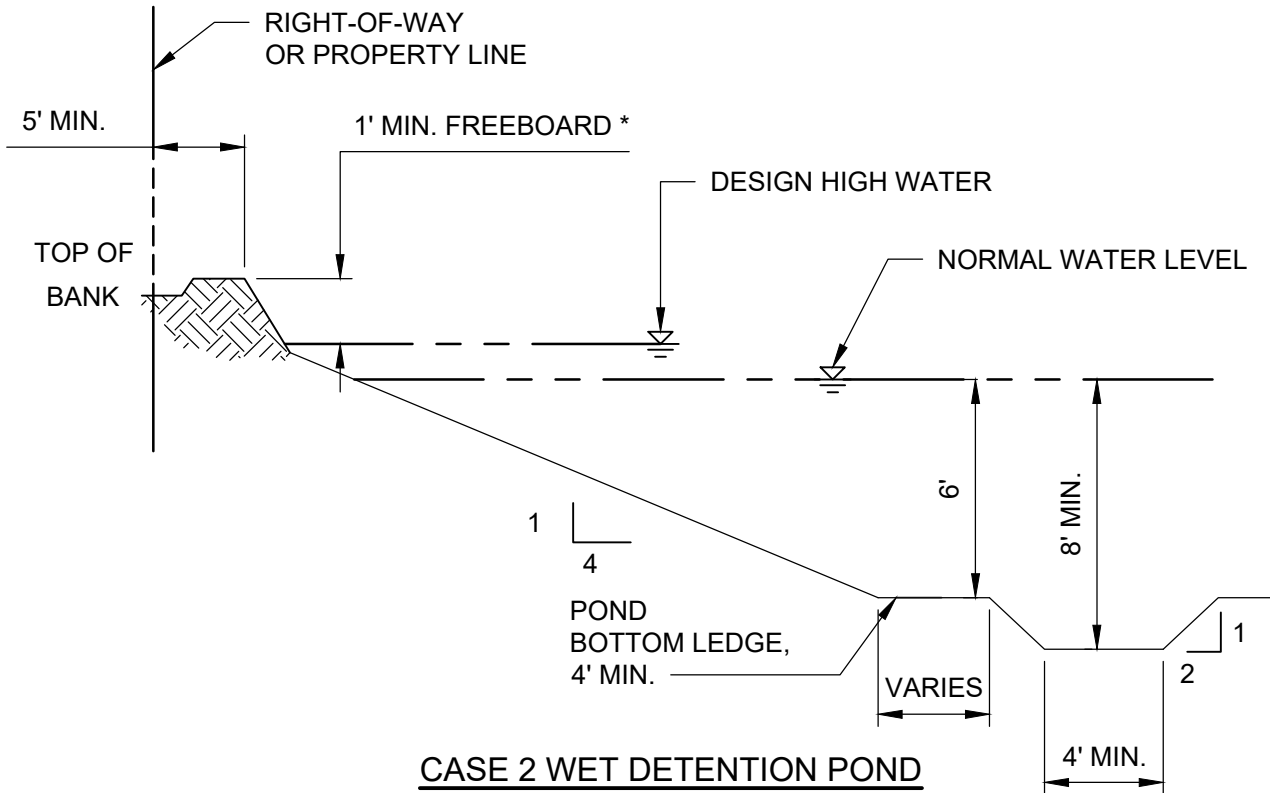

CASE 2 WET DETENTION POND

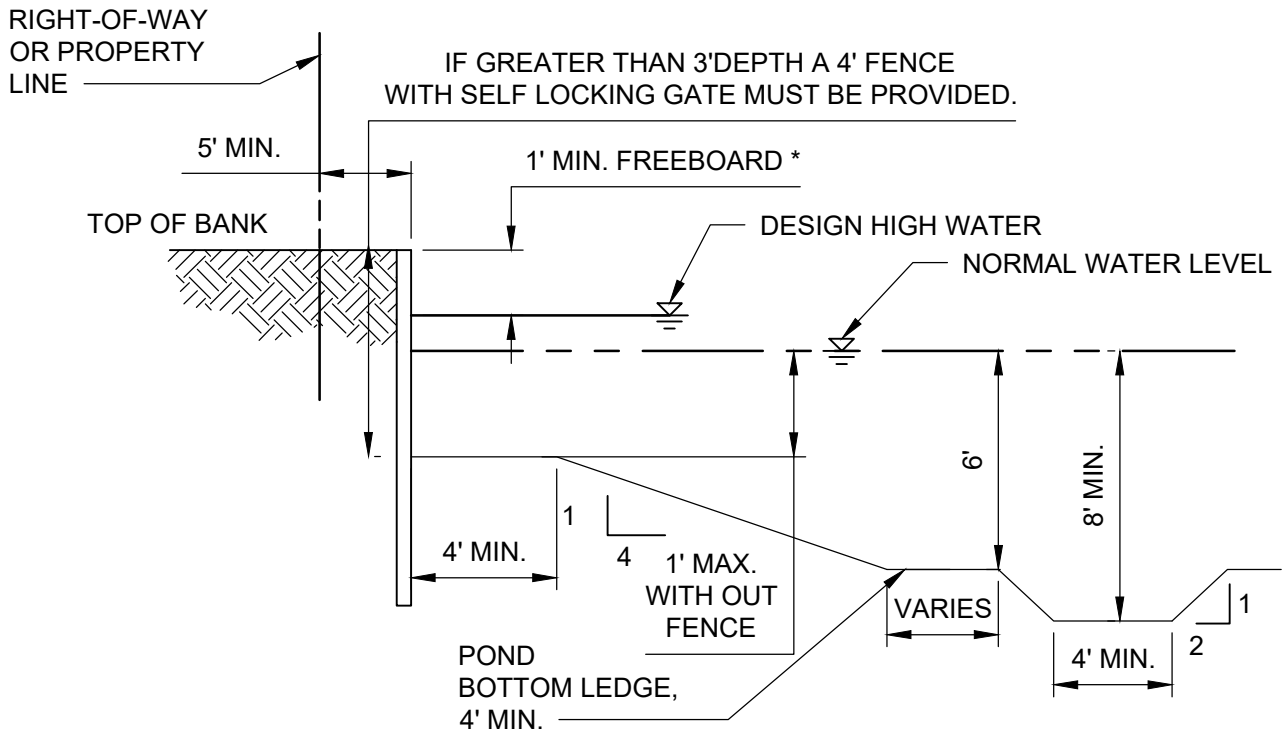

CASE 3 WET DETENTION POND

*IF THE BASIN IS CONSTRUCTED HIGHER THAN THE ADJACENT LAND, A 1-FOOT MIN. FREEBOARD IS REQUIRED FOR ALL DESIGN STORMS.

DETENTION POND DETAIL CASE 2 & 3	CITY OF JACKSONVILLE STANDARD	N.T.S.	PLATE D-1002
		DATE DRAWN	7-20-93
		REVISED DATE	11-21-24

4' FENCE WITH SELF LOCKING GATE
WHERE REQUIRED.

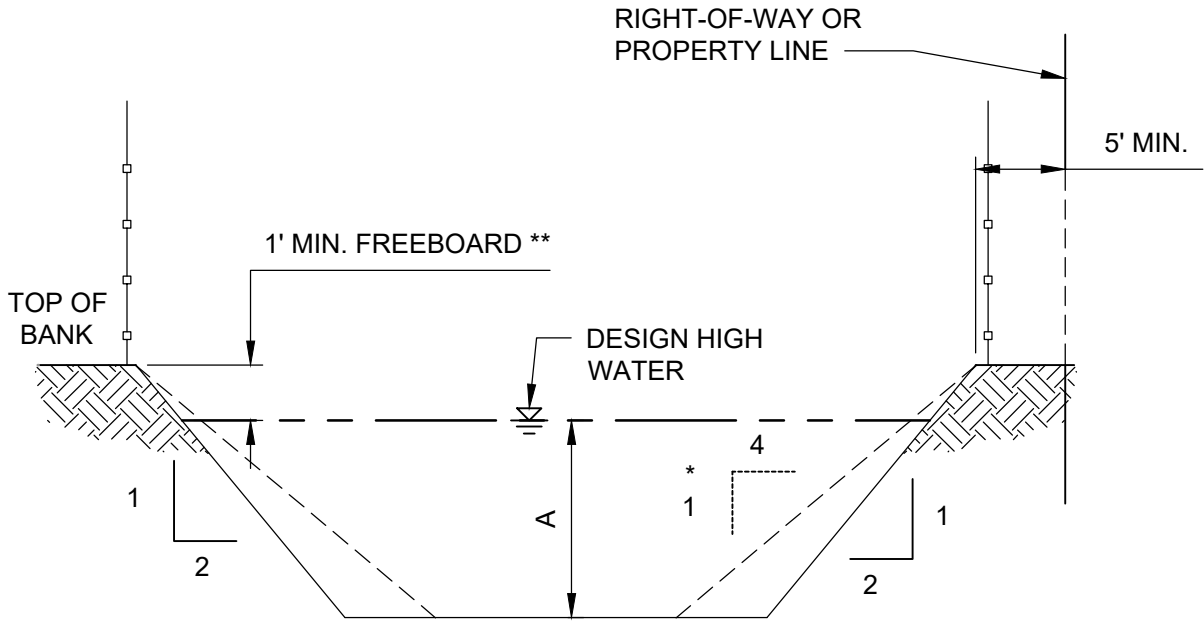

CASE 4 DRY DETENTION POND

A

	0' - 2'	NO FENCE REQUIRED
*	> 2'	FENCE REQUIRED OR 4 TO 1 SIDE SLOPES

**IF THE BASIN IS CONSTRUCTED HIGHER THAN THE ADJACENT LAND, A 1-FOOT
MIN. FREEBOARD IS REQUIRED FOR ALL DESIGN STORMS.

DETENTION POND DETAIL
CASE 4

CITY OF
JACKSONVILLE
STANDARD

N.T.S.

PLATE D-1003

DATE DRAWN 7-20-93

REVISED DATE 11-21-24

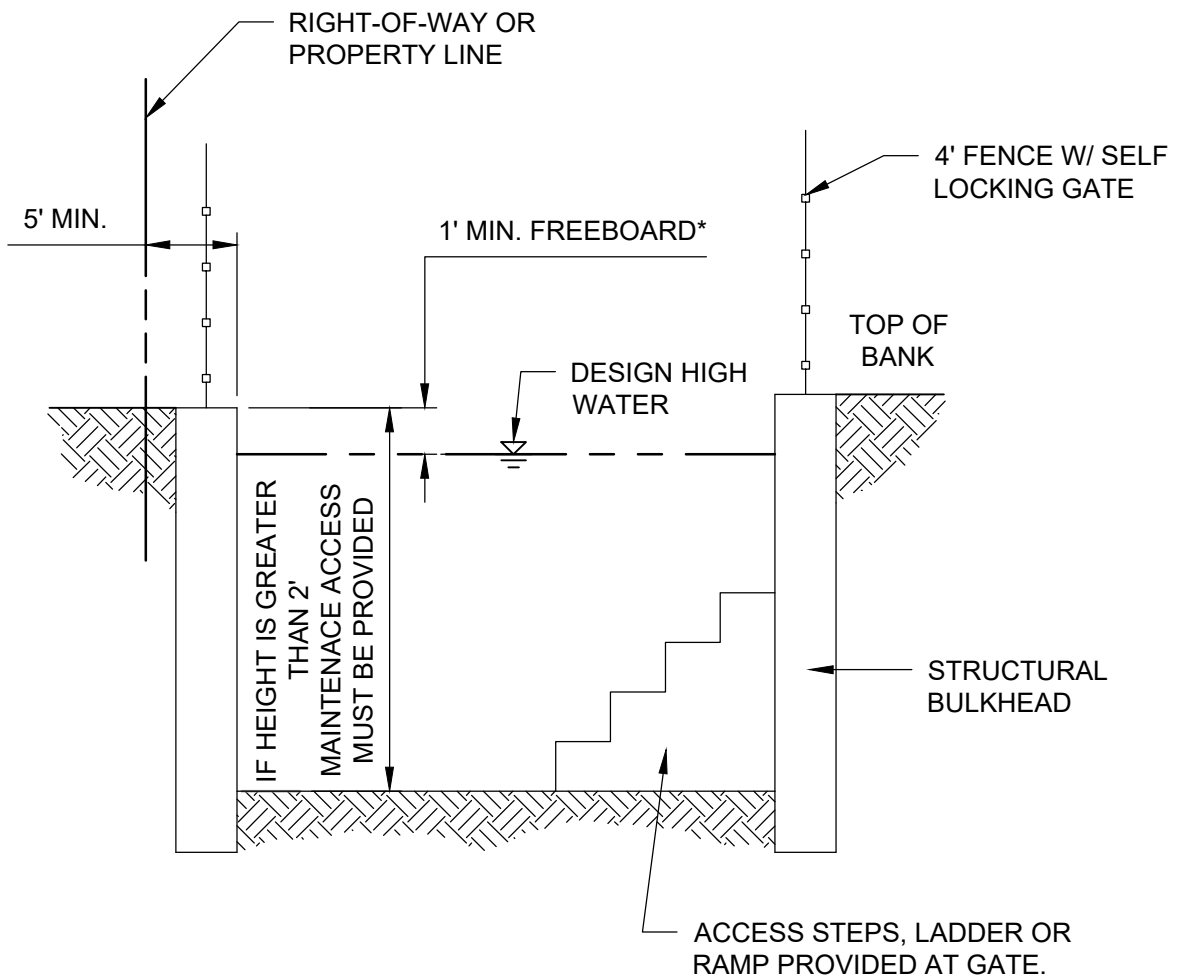

CASE 5 DRY DETENTION POND

*IF THE BASIN IS CONSTRUCTED HIGHER THAN THE ADJACENT LAND, A 1-FOOT MIN. FREEBOARD IS REQUIRED FOR ALL DESIGN STORMS.

DETENTION POND DETAIL
CASE 5

**CITY OF
JACKSONVILLE
STANDARD**

N.T.S.

PLATE D-1004

DATE DRAWN 7-20-93

REVISED DATE 11-21-24

DEPARTMENT OF PUBLIC WORKS
ENGINEERING DIVISION
LANDSCAPE STANDARD SECTION
INDEX

Series 100 PLANTING

L-101 Tree/Palm Planting

L-102 Rootball Anchoring System

L-103 Shrub/Groundcover Planting

L-104 Paver Band Detail

L-105 Palm Tree Staking in Tree Well

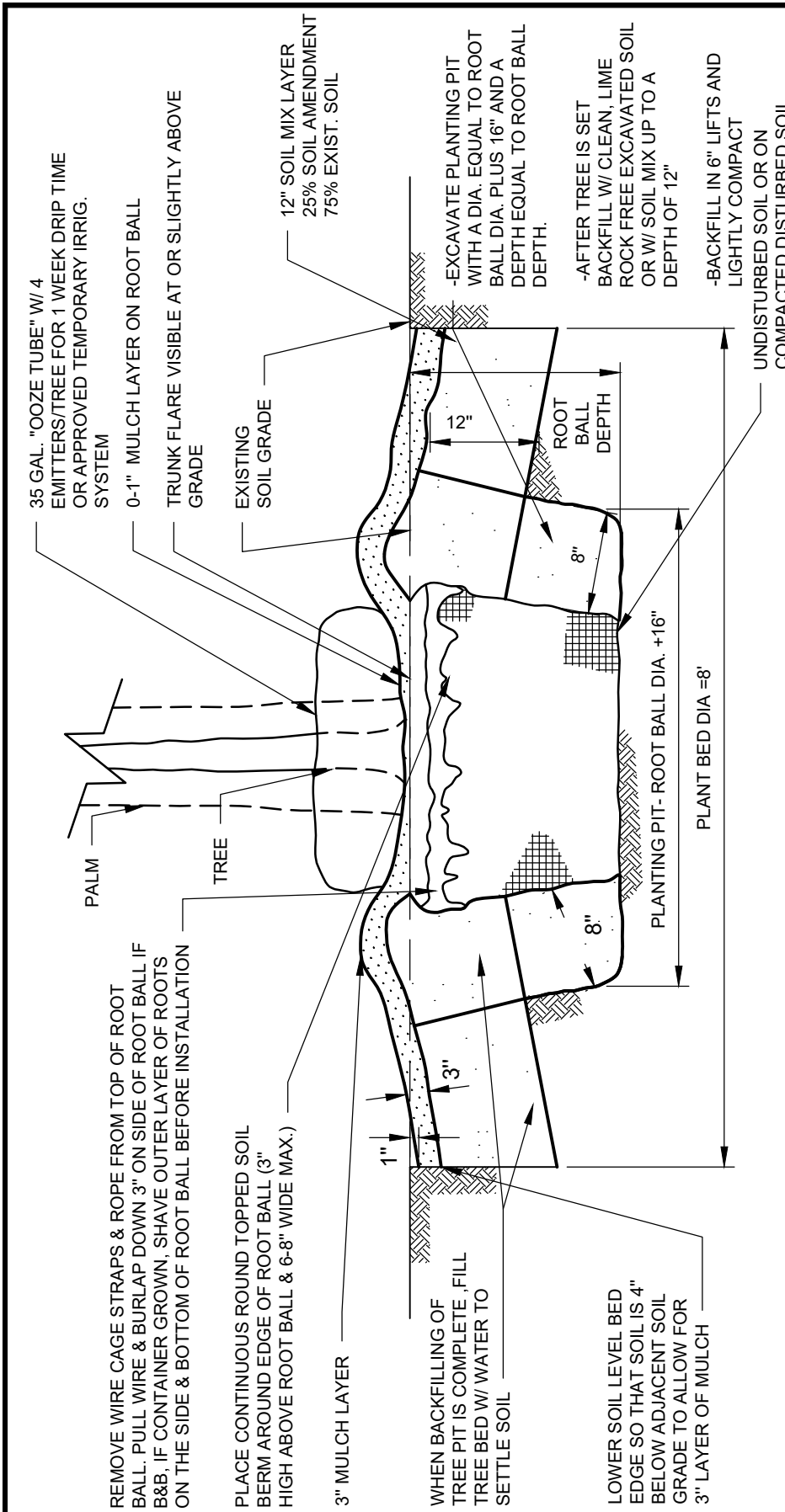

*SINGLE TRUNK TREE CALIPER	*SMALL OR MULTI-TRUNKED TREE HEIGHT	*PLANTING BED DIAMETER
1" CAL	4'	6'
2" CAL	6'	8'
3" CAL	10'	8'
4" CAL	12'	10'
5" CAL	14'	10'
6"-7" CAL	18'	10'
PALMS	-	8'

- NOTES:**
- ALL PLANTS TO CONFORM TO FL. NO. 1 GRADE OR BETTER.
 - EMERGENT SHADE TREES MAY BE EITHER BALLED AND BURLAPPED OR TREE SPADED. SMALL AND MEDIUM-SIZED TREES MAY BE CONTAINER GROWN (CG), BALLED AND BURLAPPED (B&B), OR TREE SPADED.
 - ALL TREES TO HAVE A SINGLE TRUNK AND DOMINANT CENTRAL STRAIGHT LEADER WITH SUBORDINATED BRANCHES, UNLESS OTHERWISE SPECIFIED AS MULTI-TRUNKED.
 - ALL REQUIRED TRUNKS OF SPECIFIED MULTI-TRUNKED TREES SHALL ORIGINATE FROM THE ROOT BALL.
 - BALLED AND BURLAPPED TREES SHALL HAVE A SOLID ROOT BALL WITH FIBROUS ROOTS THAT HAVE BEEN "HARDENED OFF" FOR A MINIMUM OF 4 WEEKS.
 - ALL CONTAINERIZED TREES SHALL HAVE A SOLID ROOT BALL THE SIZE OF THE SPECIFIED CONTAINER BUT SHALL NOT BE ROOT BOUND.

TREE/PALM PLANTING

CITY OF JACKSONVILLE STANDARD

N.T.S.	PLATE L-101
DATE DRAWN	1-6-25
REVISED DATE	1-6-25

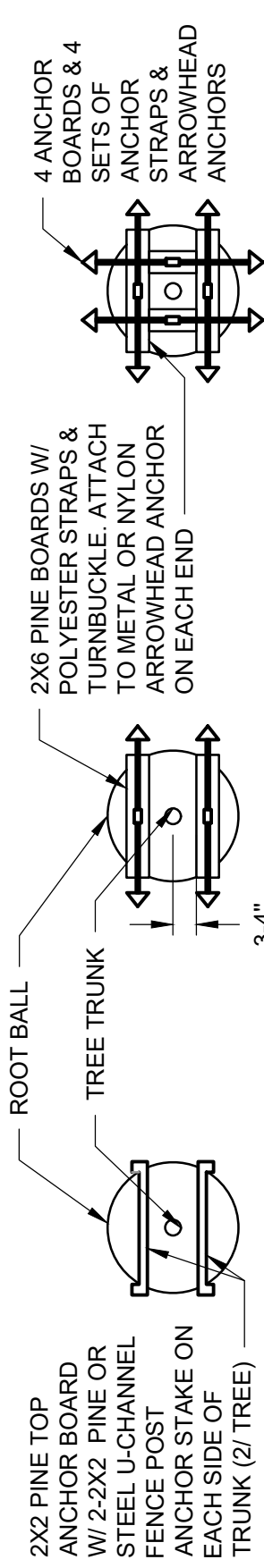

ANCHOR SYSTEM 1
TO 3 1/2" CAL. TREE

ANCHOR SYSTEM 2
TO 4 1/2" CAL. TREE

ANCHOR SYSTEM 3
TO 6 1/2" CAL. TREE

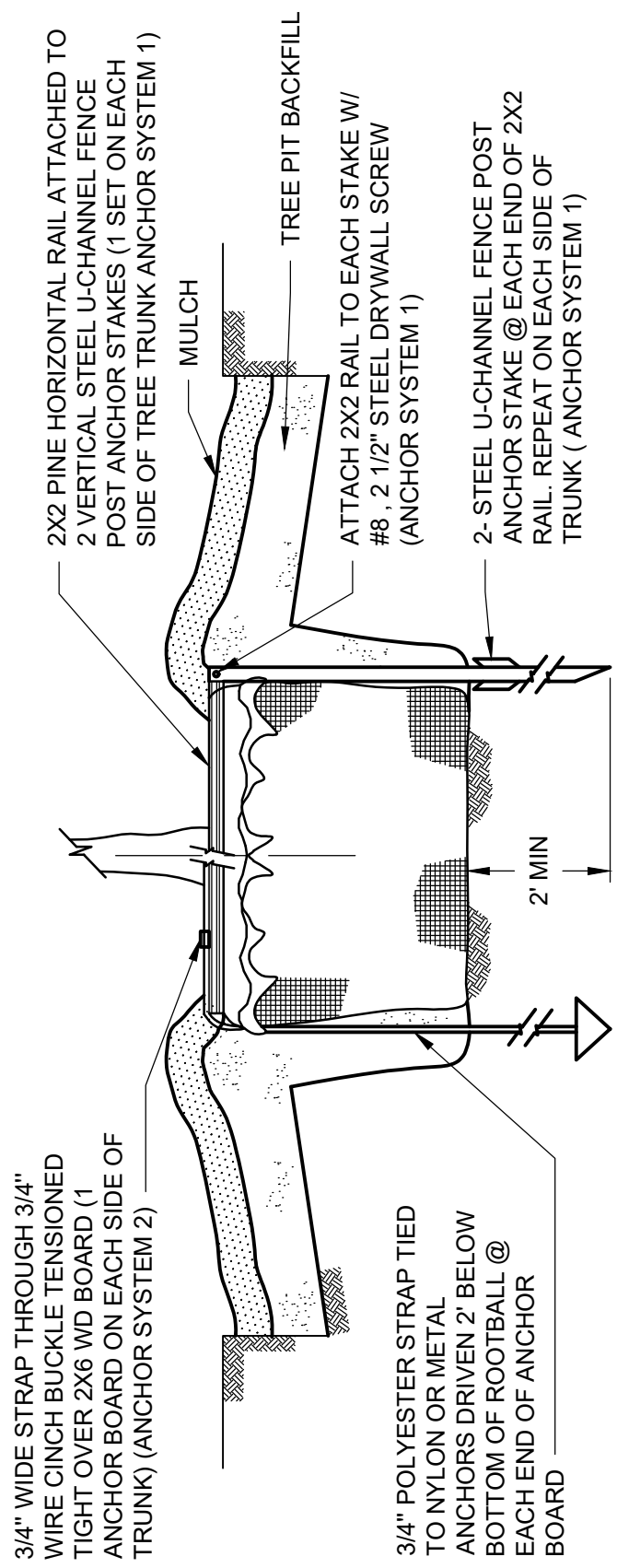

NOTE:

- CITY'S CERTIFIED ARBORIST MAY SPECIFY ALTERNATIVE SUPPORT SYSTEMS FOR ROOT BALLS WITH LESS SOIL STRUCTURE AND/OR TREES WITH MORE GRAVITATIONAL OR WINDFORCE LEVERAGE IN THE CANOPY.

ROOTBALL ANCHORING SYSTEM

CITY OF JACKSONVILLE STANDARD

N.T.S.

PLATE L-102

DATE DRAWN 1-6-25

REVISED DATE 1-6-25

* MIN. 24" FOR SPREADING PLANTS (i.e., JUNIPER, COONTIE, FAKAHATCHEE GRASS, SAW PALMETTO & LARGE SHRUBS

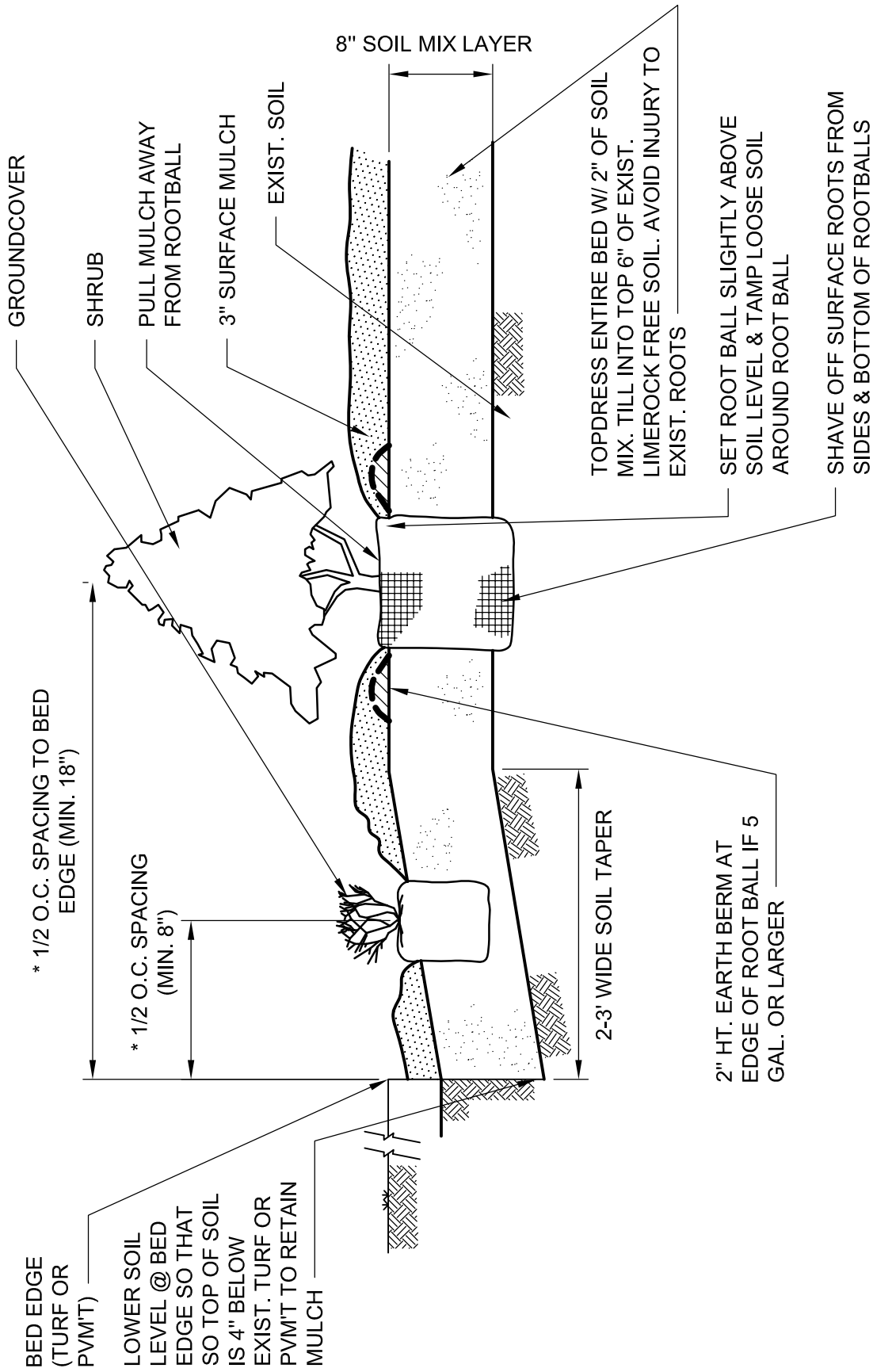

SHRUB/GROUND COVER
PLANTING

CITY OF
JACKSONVILLE
STANDARD

N.T.S.

PLATE L-103

DATE DRAWN

REVISED DATE

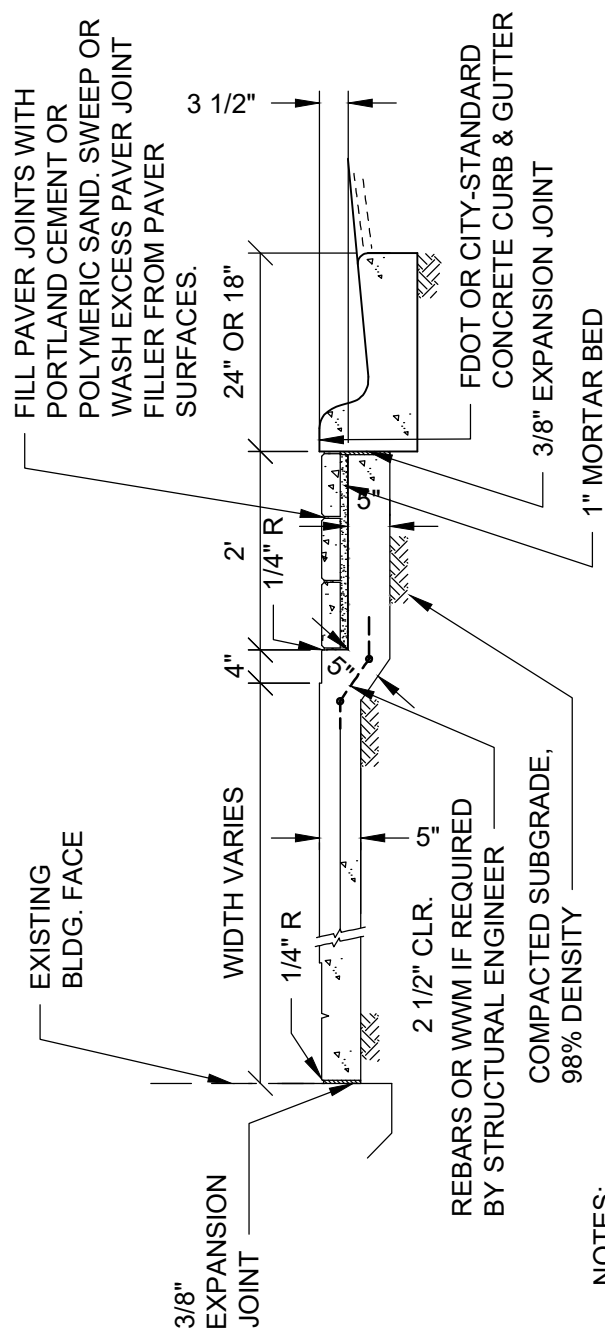

NOTES:

1. PAVERS CAN HAVE MORTARED JOINTS AS AN ALTERNATIVE INSTALLATION, IF DESIRED.
2. REFER TO COJ STANDARD SIDEWALK DETAILS AND DOWNTOWN DESIGN GUIDELINES FOR SIDEWALK JOINTS AND FINISH DETAIL STANDARDS.

SIDEWALK PAVER BAND - RIGID INSTALLATION

PAVER BAND DETAIL	CITY OF JACKSONVILLE STANDARD		N.T.S.	PLATE L-104
			DATE DRAWN	1-6-25
			REVISED DATE	1-6-25

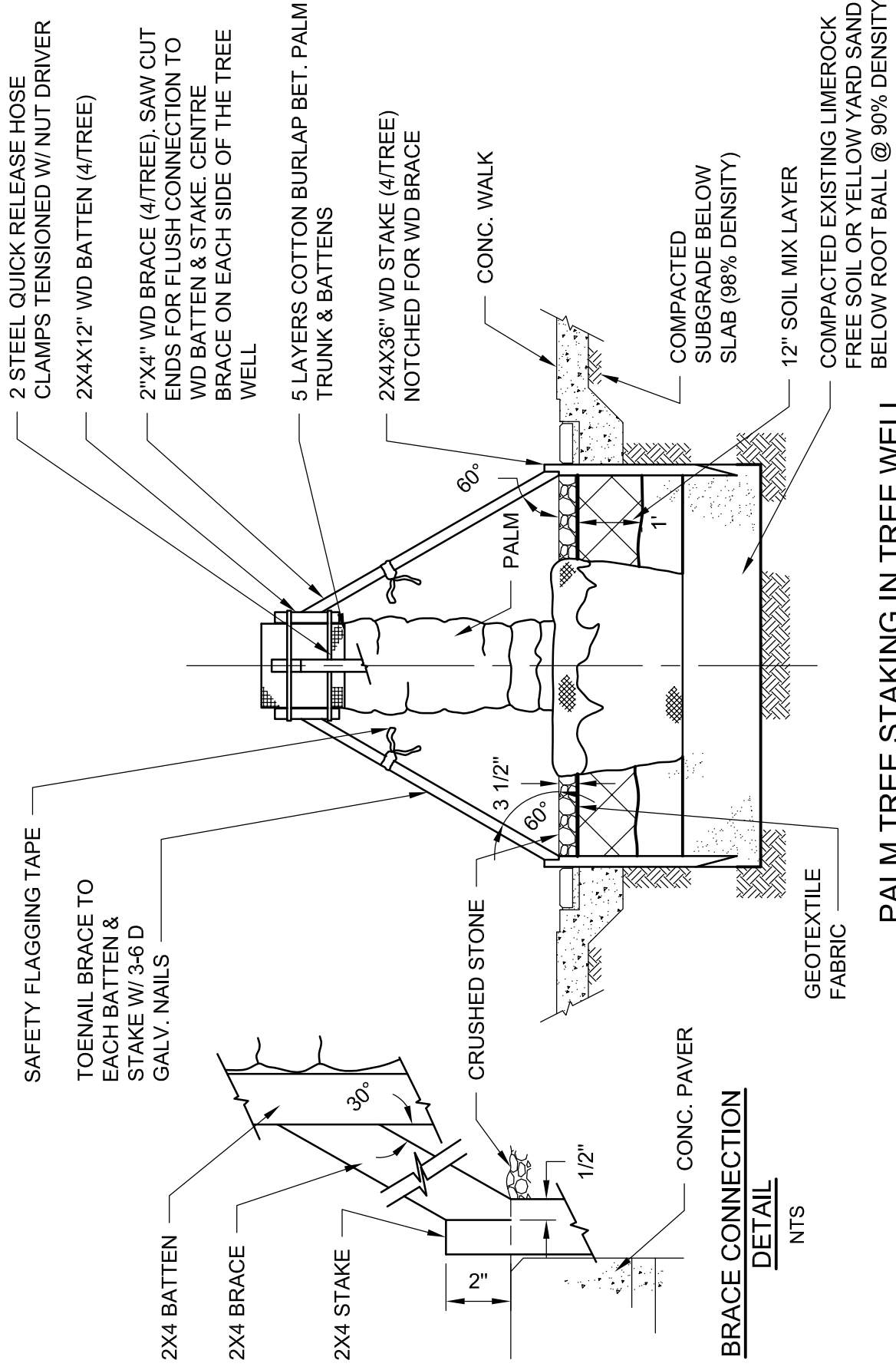

PALM TREE STAKING IN TREE WELL

**BRACE CONNECTION
DETAIL
NTS**

PALM TREE STAKING IN TREE WELL

CITY OF JACKSONVILLE STANDARD

1"=1'

PLATE L-105

DATE DRAWN

REVISED DATE