

310.90 DE10

# **Standard Land Use Coding Manual**

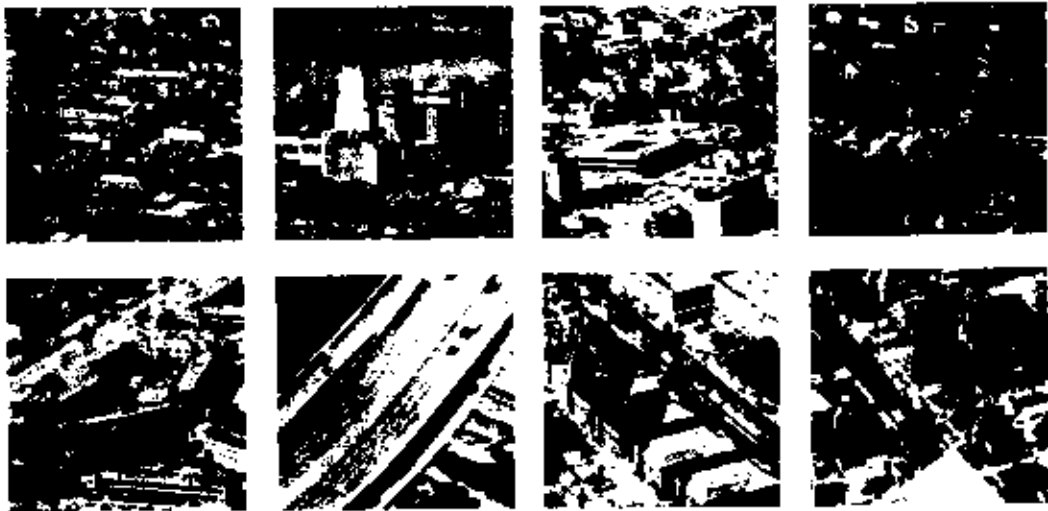

***A Standard System for Identifying  
and Coding Land Use Activities***

First Edition January 1965

Urban Renewal Administration  
Housing and Home Finance Agency  
and  
Bureau of Public Roads  
Department of Commerce

Washington, D.C.



**Standard  
Land  
Use  
Coding  
Manual**



***A Standard System for Identifying and Coding  
Land Use Activities***

**First Edition**

**January 1965**

**Urban Renewal Administration  
Housing and Home Finance Agency  
and  
Bureau of Public Roads  
Department of Commerce**

**Washington, D.C.**

## FOREWORD

□ For the past few years the Urban Renewal Administration of the Housing and Home Finance Agency and the Bureau of Public Roads of the Department of Commerce have taken extensive steps to obtain close coordination between their programs. This follows both in spirit and letter the formal agreement reached by the Administrator of the Housing and Home Finance Agency and the Secretary of the Department of Commerce.

These coordinating relationships have been developed to a high degree in connection with the comprehensive planning programs in metropolitan areas having particular concern with transportation needs, and usually identified as land use-transportation studies. Such studies often have the joint financial support of both agencies through grants under the URA Urban Planning Assistance (701) Program and reimbursement of State and local expenditures from highway planning and research funds administered by the Bureau of Public Roads. Joint technical support also is often provided.

An outgrowth of these coordinating endeavors has been the identification of several subjects of interest to people working in the urban and transportation planning fields. One such subject that was called to our attention very early in the joint activities concerned the multiplicity of systems used in classifying land use. This publication is the result of steps taken jointly by both agencies to develop a possible standard land use coding system.

It is recognized that this edition is only the initial effort to develop a uniform coding system and that the application of this system in field operations will result in further refinements. Published under the auspices of both agencies, this is an expression of the day-to-day working relationships between the two agencies. We hope that it will further encourage State and local officials with urban development planning and transportation planning responsibilities to develop similar close working relationships.

The Urban Renewal Administration and the Bureau of Public Roads both recommend that where appropriate the detailed system of categories presented in this publication be used for the collection and coding of information describing land use activity. *However, this recommendation is not to be considered as a requirement in any programs sponsored by the two agencies.*

Communities and planning programs vary considerably as to their capacity to use and manage detailed land use data, and for this reason, it would be inappropriate to require the use of the standard coding system in all programs at this time. This coding system will be particularly useful in those urban areas where the need for *detailed* land use information has been clearly established and where the capacity exists in the form of data handling procedures and equipment for efficiently coding, preserving, and retrieving the data. However, each community must consider for its own area the existing demands and future needs for land use activity data together with the relative costs of different methods of collecting and handling the data before deciding the appropriate level of detail at which the data are to be recorded and coded (i.e. the one-, two-, three-, or four-digit level). In those urban areas where the decision has been made to collect and code the data

## FOREWORD

□ For the past few years the Urban Renewal Administration of the Housing and Home Finance Agency and the Bureau of Public Roads of the Department of Commerce have taken extensive steps to obtain close coordination between their programs. This follows both in spirit and letter the formal agreement reached by the Administrator of the Housing and Home Finance Agency and the Secretary of the Department of Commerce.

These coordinating relationships have been developed to a high degree in connection with the comprehensive planning programs in metropolitan areas having particular concern with transportation needs, and usually identified as land use-transportation studies. Such studies often have the joint financial support of both agencies through grants under the URA Urban Planning Assistance (701) Program and reimbursement of State and local expenditures from highway planning and research funds administered by the Bureau of Public Roads. Joint technical support also is often provided.

An outgrowth of these coordinating endeavors has been the identification of several subjects of interest to people working in the urban and transportation planning fields. One such subject that was called to our attention very early in the joint activities concerned the multiplicity of systems used in classifying land use. This publication is the result of steps taken jointly by both agencies to develop a possible standard land use coding system.

It is recognized that this edition is only the initial effort to develop a uniform coding system and that the application of this system in field operations will result in further refinements. Published under the auspices of both agencies, this is an expression of the day-to-day working relationships between the two agencies. We hope that it will further encourage State and local officials with urban development planning and transportation planning responsibilities to develop similar close working relationships.

The Urban Renewal Administration and the Bureau of Public Roads both recommend that where appropriate the detailed system of categories presented in this publication be used for the collection and coding of information describing land use activity. *However, this recommendation is not to be considered as a requirement in any programs sponsored by the two agencies.*

Communities and planning programs vary considerably as to their capacity to use and manage detailed land use data, and for this reason, it would be inappropriate to require the use of the standard coding system in all programs at this time. This coding system will be particularly useful in those urban areas where the need for *detailed* land use information has been clearly established and where the capacity exists in the form of data handling procedures and equipment for efficiently coding, preserving, and retrieving the data. However, each community must consider for its own area the existing demands and future needs for land use activity data together with the relative costs of different methods of collecting and handling the data before deciding the appropriate level of detail at which the data are to be recorded and coded (i.e. the one-, two-, three-, or four-digit level). In those urban areas where the decision has been made to collect and code the data

at a grosser level of detail, i.e. at the two-or three digit level, this coding system can still provide a basis for comparability if the categories are meaningful for the objectives of the particular study.

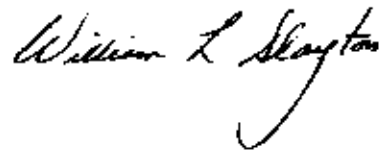

WILLIAM L. SLAYTON,  
*Commissioner,  
Urban Renewal Administration,  
Housing and Home Finance Agency.*



REX M. WHITTON,  
*Federal Highway Administrator,  
Bureau of Public Roads,  
U.S. Department of Commerce.*

Deputy Assistant Commissioner for Urban Planning, Urban Renewal Administration, Housing and Home Finance Agency, and was directed jointly by him and Michael Lash, Chief, Urban Development Branch, Bureau of Public Roads, Department of Commerce.

The text and coding system in this publication have been developed by Harold A. Merrill, urban planner, Urban Renewal Administration, and Jacob Silver, geographer, Urban Development Branch, Bureau of Public Roads.

The study of land use classification and coding systems which provided the groundwork for this manual was conducted and developed through a Housing and Home Finance Agency contract with Barton-Aschman Associates, Inc., Evanston, Ill., under the supervision of Robert B. Teska, project administrator, and with overall direction and assistance by Rodney E. Engelen, principal associate.

Prior to the preparation of this text and coding system, the following persons reviewed copies of the preliminary study prepared by Barton-Aschman Associates, Inc., and their comments and suggestions, which are greatly appreciated, have been helpful in developing the standard land use coding system to this stage:

James R. Anderson, Department of Geography, University of Florida, Gainesville, Fla.

Kurt W. Bauer, Executive Director, Southeastern Wisconsin Regional Planning Commission, Waukesha, Wis.

C. R. Brady, Director, Valley Area Transportation Study, Tempe, Ariz.

Milton Breivogel, Director of Planning, County of Los Angeles Regional Planning Commission, Los Angeles, Calif.

E. Wilson Campbell, Director, Chicago Area Transportation Study, Chicago, Ill.

Robert D. Campbell, Department of Geography and Regional Science, George Washington University, Washington, D.C.

J. Douglas Carroll, Jr., Executive Director, Tri-State Transportation Committee, New York, N.Y.

F. Stuart Chapin, Jr., Research Director, Center for Urban and Regional Studies, University of North Carolina, Chapel Hill, N.C.

Robert C. Colwell, Director, Program Division, Federal Housing Administration, Housing and Home Finance Agency, Washington, D.C.

J. Tait Davis, Department of Geography and Regional Science, George Washington University, Washington, D.C.

Richard D. Duke, Institute for Community Development and Services, Michigan State University, East Lansing, Mich.

Henry Fagin, Department of Urban and Regional Planning, University of Wisconsin, Madison, Wis.

v

## **ACKNOWLEDGMENTS**

□ The land use coding system in this publication represents the thinking and experience over many years of a large number of individuals and agencies within and outside of the Federal Government. This undertaking, the purposes of which are set forth in chapter I, Introduction, was conceived by Richard Ives, Deputy Assistant Commissioner for Urban Planning, Urban Renewal Administration, Housing and Home Finance Agency, and was directed jointly by him and Michael Lash, Chief, Urban Development Branch, Bureau of Public Roads, Department of Commerce.

The text and coding system in this publication have been developed by Harold A. Merrill, urban planner, Urban Renewal Administration, and Jacob Silver, geographer, Urban Development Branch, Bureau of Public Roads.

The study of land use classification and coding systems which provided the groundwork for this manual was conducted and developed through a Housing and Home Finance Agency contract with Barton-Aschman Associates, Inc., Evanston, Ill., under the supervision of Robert B. Teska, project administrator, and with overall direction and assistance by Rodney F. Engelen, principal associate.

Prior to the preparation of this text and coding system, the following persons reviewed copies of the preliminary study prepared by Barton-Aschman Associates, Inc., and their comments and suggestions, which are greatly appreciated, have been helpful in developing the standard land use coding system to this stage:

James R. Anderson, Department of Geography, University of Florida, Gainesville, Fla.

Kurt W. Bauer, Executive Director, Southeastern Wisconsin Regional Planning Commission, Waukesha, Wis.

C. R. Brady, Director, Valley Area Transportation Study, Tempe, Ariz.

Milton Breivogel, Director of Planning, County of Los Angeles Regional Planning Commission, Los Angeles, Calif.

E. Wilson Campbell, Director, Chicago Area Transportation Study, Chicago, Ill.

Robert D. Campbell, Department of Geography and Regional Science, George Washington University, Washington, D.C.

J. Douglas Carroll, Jr., Executive Director, Tri-State Transportation Committee, New York, N.Y.

F. Stuart Chapin, Jr., Research Director, Center for Urban and Regional Studies, University of North Carolina, Chapel Hill, N.C.

Robert C. Colwell, Director, Program Division, Federal Housing Administration, Housing and Home Finance Agency, Washington, D.C.

J. Tait Davis, Department of Geography and Regional Science, George Washington University, Washington, D.C.

Richard D. Duke, Institute for Community Development and Services, Michigan State University, East Lansing, Mich.

Henry Fagin, Department of Urban and Regional Planning, University of Wisconsin, Madison, Wis.

William L. Garrison, Department of Geography, Northwestern University, Evanston, Ill.

Douglas F. Haist, Chief of Urban and Advance Planning, Wisconsin State Highway Commission, Madison, Wis.

John R. Hamburg, Associate Director, Upstate New York Transportation Studies, Albany, N.Y.

Irving Hand, Planning Director, Metropolitan Planning Commission, Nashville, Tenn.

Britton Harris, Research Coordinator, Penn-Jersey Transportation Study, Philadelphia, Pa.

Patrick Healy, Executive Director, American Municipal Association, Washington, D.C.

Edward F. R. Hearle, The Rand Corporation, Santa Monica, Calif.

Roy D. Hockensmith, Director, Soil Survey Operations, Soil Conservation Service, U.S. Department of Agriculture, Washington, D.C.

Walter K. Johnson, Deputy Director, Wisconsin Department of Resource Development, Madison, Wis.

Stephen A. Kaufman, Deputy Director, Regional Planning Commission, Cleveland, Ohio.

Robert Kochanowski, Study Director, Pittsburgh Area Transportation Study, Pittsburgh, Pa.

Norman E. Landgren, Leader, Land Use Investigations, Economic Research Service, U.S. Department of Agriculture, Washington, D.C.

C. David Laeks, Director, Twin Cities Metropolitan Planning Commission, St. Paul, Minn.

David D. Longmaid, Executive Director, Penn-Jersey Transportation Study, Philadelphia, Pa.

John K. Mladinov, Director, Puget Sound Regional Transportation Study, Seattle, Wash.

Dennis O'Harrow, Executive Director, American Society of Planning Officials, Chicago, Ill.

Paul Oppermann, Executive Director, Northeastern Illinois Metropolitan Area Planning Commission, Chicago, Ill.

Russell H. Riley, Partner, Harland Bartholomew and Associates, St. Louis, Mo.

Victor Roterus, Economic Adviser to the Administrator, Area Redevelopment Administration, Washington, D.C.

Morton J. Schussheim, Assistant Administrator for Program Policy, Housing and Home Finance Agency, Washington, D.C.

John W. Shively, Assistant Commissioner for Technical Standards, Urban Renewal Administration, Housing and Home Finance Agency, Washington, D.C.

Herbert H. Smith, President, Herbert H. Smith Associates, West Trenton, N.J.

Oscar Sutermeister, Consultant to Division of Environmental Engineering and Food Protection, Public Health Service, Washington, D.C.

Stanley B. Tankel, Planning Director, Regional Plan Association, Inc., New York, N.Y.

Jack Urner, Acting Director, Metropolitan Planning Commission, Portland, Oreg.

Alan M. Voorhees, President, Alan M. Voorhees and Associates, Washington, D.C.

Louis R. Wetmore, Consultant, Urbana, Ill.



Sidney H. Williams, Partner, Williams and Moline, San Francisco, Calif.  
Robert I. Williams, Executive Director, American Institute of Planners, Washington, D.C.  
Donald R. Woodard, Chief of Long Range Planning, Tulsa Metropolitan Area Planning Commission, Tulsa, Okla.  
F. Houston Wynn, Wilbur Smith and Associates, New Haven, Conn.

In addition, the Urban Renewal Administration and the Bureau of Public Roads are indebted to the following for their comments and special counsel in the final stages of this undertaking:

Philip J. Barbato, Highway Engineer, Urban Planning Division, Bureau of Public Roads, Washington, D.C.  
George F. Burks, Director, Division of Programs and Special Projects, Forest Service, U.S. Department of Agriculture, Washington, D.C.  
Marion Clawson, Director, Land Use and Management Program, Resources for the Future, Inc., Washington, D.C.  
Sidney Goldstein, Economic Adviser, Office of Planning, Bureau of Public Roads, Washington, D.C.  
Frederick O'R. Hayes, Assistant Commissioner for Urban Planning and Community Development, Urban Renewal Administration, Housing and Home Finance Agency, Washington, D.C.  
Bruce D. McDowell, Analyst, Advisory Commission on Intergovernmental Relations, Washington, D.C.  
Jerome P. Pickard, Director of Research, Urban Land Institute, Washington, D.C.  
Charles Stewart, Consultant to the Land Use Statistics Committee, Resources for the Future, Inc., Washington, D.C.  
Hugh H. Wooton, Agricultural Economist, Economic Research Service, U.S. Department of Agriculture, Washington, D.C.

Although many different groups and persons were involved in the development of this system, the responsibility for the final product as contained herein rests with the Housing and Home Finance Agency and the Department of Commerce.□

# **Table of Contents**

<b>FOREWORD</b> .....	iii
<b>ACKNOWLEDGMENTS</b> .....	v
<b>I INTRODUCTION</b> .....	1
<b>II THE APPROACH</b> .....	3
<b>A. INVESTIGATION AND CONCLUSIONS</b> .....	3
<b>B. THE "ACTIVITY" CATEGORIES</b> .....	4
<b>C. THE NEXT STEP</b> .....	6
<b>III USE OF THE CATEGORIES</b> .....	9
<b>A. DESCRIPTION AND RATIONALE</b> .....	9
1. General Structure .....	9
2. Purpose and Use of the Auxiliary Codes .....	10
3. The Use of Standard Industrial Classification Nomenclature .....	13
4. Coding Ownership .....	14
5. Coding Rural Activities .....	15
6. Rationale Behind Some of the Categories .....	15
a. Household units .....	15
b. Manufacturing categories .....	16
c. Warehousing and storage categories .....	16
d. Undeveloped and unused land .....	17
e. Vacant floor area .....	17
f. Under construction categories .....	17
<b>B. APPLICATION</b> .....	18
1. Identifying and Coding Land Use Activities .....	18
2. Standardization and Flexibility .....	18
<b>IV THE CATEGORIES AND CODE NUMBERS</b> .....	29
<b>A. A STANDARD SYSTEM FOR IDENTIFYING AND CODING LAND USE ACTIVITIES—ONE- AND TWO-DIGIT LEVELS</b> .....	29
<b>B. A STANDARD SYSTEM FOR IDENTIFYING AND CODING LAND USE ACTIVITIES—TWO-, THREE-, AND FOUR-DIGIT LEVELS</b> .....	32
<b>C. ALPHABETIC INDEX OF LAND USE ACTIVITIES</b> .....	81
<b>APPENDIXES</b> .....	107
<b>APPENDIX 1 Coding System for Identifying Ownership</b> .....	107
<b>APPENDIX 2 Coding System for Identifying Farms and Farm Uses</b> .....	107
<b>APPENDIX 3—Coding System for Identifying Structures Containing "Household Units"</b> .....	110

## ***I Introduction***

□ Land use statistics are required for a variety of planning purposes at the local, regional, and State levels. The need is growing for the collection of land use information in a form that will allow comparability between localities and between regions, and that will also permit the study of trends over time in individual urban areas. The lack of uniformity has led to duplication of effort in many cities. Often land use data collected for one specific purpose had little or no value for another but similar purpose, requiring a new field inventory within a short space of time. With the increasing attention being focused on urban planning and research and with the growing amounts of public funds being invested in land use inventories, the need for greater uniformity is quite plain and past due.

Amendments to section 701 of the Housing Act of 1954<sup>1</sup> in 1959 and in 1961, and the Federal-Aid Highway Act of 1962,<sup>2</sup> greatly increased the need to collect land use information that is equally useful to both urban development planning and transportation planning programs. These amendments placed a new and greater emphasis on the need to integrate urban development planning and transportation planning. Among the common denominators to both processes that allow such integration are a land use inventory and a land use forecast. A survey of existing land uses and the updating of such information, together with forecasts of the future growth and distribution of land uses, is essential in the continuous process of comprehensive planning for urban development and transportation planning.

Both the Urban Renewal Administration and the Bureau of Public Roads are aware of the important role a standard land use coding system can play in this planning process. Such a system will facilitate the interchange of statistical information and research findings between communities and public and private organizations. It would also reduce in a significant way existing obstacles to the comparison, analysis, and updating of land use data in many of our urban areas. This cooperative effort by the two agencies is a step toward advancing both these ends. □

<sup>1</sup> 40 U.S.C. 461.

<sup>2</sup> 23 U.S.C. 134.

## ***II The Approach***

### **A. INVESTIGATION AND CONCLUSIONS**

In 1962 the United Renewal Administration with the cooperation of the Bureau of Public Roads and with the technical assistance of the consulting firm of Barton-Aschman Associates, Inc., of Evanston, Ill., began an investigation to determine whether a uniform and universally applicable land use classification and coding system was feasible. Besides serving the programs of the two agencies, the coding system would be such that it could be used for various types of studies and analyses in small communities with populations under 50,000 as well as in large metropolitan areas.

The study began with a review of land use classification systems already in use. Existing systems, or proposals for systems of land use classification, were gathered from over 50 different sources and reviewed in detail. Numerous persons were contacted either in person or by mail, including land use specialists from 12 of the largest urban planning and transportation planning studies then underway. In addition, valuable suggestions and help were received from the Land Use Statistics Committee of the Resources for the Future, Inc., under the chairmanship of Dr. Marion Clawson. That Committee was also seeking a solution to the problem of achieving comparability in land use statistics, and therefore, the work of the two groups was joined at several points to the mutual advantage of both.

One of the most significant conclusions of this exploration is that different characteristics or dimensions that describe land should *not* be combined into a single classification system if the system is to meet the objectives outlined above. For example, in some land use inventory projects, categories of activity have been combined with measures of intensity of use, such as the number of dwelling units in a structure, or with type of ownership, such as private and governmental. In other systems structure type, such as office building, has also been included. This mixing of characteristics restricts the use of any classification and coding scheme.

Instead of combining into one category several characteristics that can describe

a piece of land, the study concluded that each separate dimension or characteristic be defined by a separate classification system. These characteristics, as illustrated in figure 1, could then be grouped as one would put together building blocks. The different characteristics that describe either a parcel of land, a structure on the parcel, or the activities on the land or within the structure are maintained separately, and they are put together in the combinations that will best fit the needs of a particular planning study. This, of course, does not mean that a variety of information cannot be collected in the same field survey. Economy of operations is possible and desirable even if a variety of different characteristics of the use of land are to be identified and recorded.

The above approach to land use description has been made possible by the very rapid changes in our technology, especially that of automatic data processing equipment. Through the use of data processing cards or electronic computer tapes, large quantities of land use information can be maintained or stored intact and in a detailed form. Through the use of electronic accounting machines or electronic computers, this detailed information can be reorganized into a variety of different classification patterns to fit the unique requirements of many types of planning studies. The computer, therefore, satisfies directly and immediately the specific requirements of a given program, and it retains the original detailed data for use in other studies. Most important of all, through the use of computers, the actual processing of detailed data can be accomplished in "machine-minutes or -hours" rather than in "man-months" or "man-years" of labor.

## B. THE "ACTIVITY" CATEGORIES

Inasmuch as "activity"<sup>3</sup> is considered to be the most important single land use characteristic for which comparability is desired, a system of categories identifying land use activities was developed. The primary purpose was to establish an extensive system of categories that would identify each land use activity and which could also be numerically coded in order to facilitate data handling on automatic data processing equipment. This, it was felt, would provide the beginning of a standard system of identification for one specific characteristic of land use.

In developing the system of activity categories, a second major conclusion was reached, and that is that no *rigid* system for classifying land use activity is feasible for broad application to all urban areas in the United States. In the past, land use classification systems have differed one from the other for numerous reasons. However, the most frequent reason for the difference appears to have been an attempt by each city to reflect in the land use classification system its own particular economic and social composition.

For example, in Hartford, Conn., the insurance industry is an important activity and for certain planning purposes it may need to be identified not only as a separate activity, but also in more detail than, say meatpacking which is not a major Hartford industry. In Washington, D.C., governmental functions are important and would be identified in more detail than they would be, for example,

---

<sup>3</sup>The term "activity" for the purposes used here is defined as an organizational unit for performing a special function and occupying identifiable space at a fixed location.

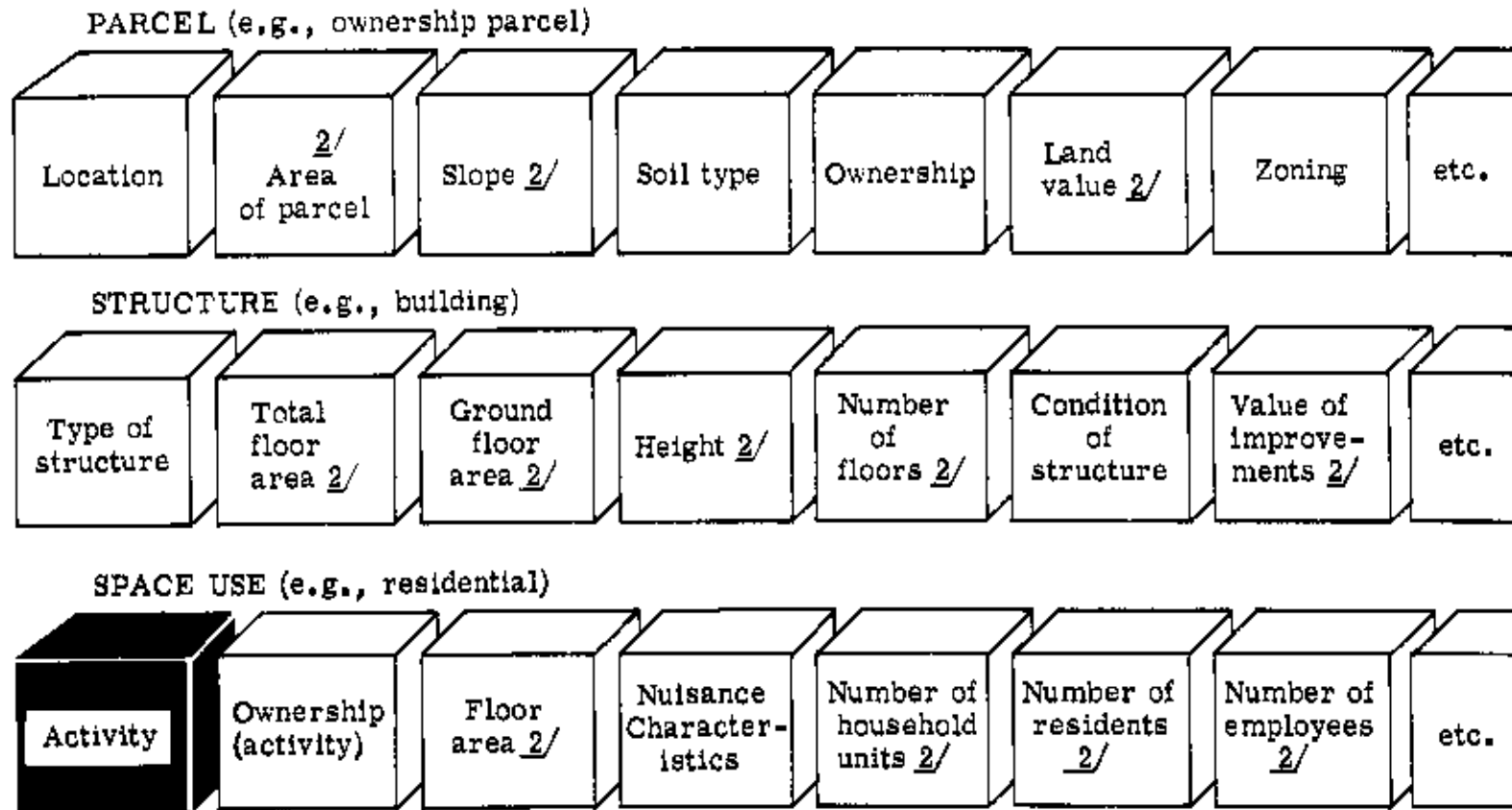

Figure 1.—An example of characteristics commonly used to describe a parcel of land <sup>1</sup>

<sup>1</sup> This figure is neither definitive in the number of characteristics shown nor does the sequence indicate relative importance. It is presented to illustrate the type of characteristics that are considered by planning agencies when describing a parcel of land. The shaded block labeled "Activity" is the characteristic being given primary consideration in this coding system.

<sup>2</sup> These characteristics can be described by an actual figure or a range in figures representing magnitude. The other characteristics cannot be described numerically and therefore, each will need a series of "word description" categories.

in Miami, Fla. One man's miscellaneous is another man's prime concern; no single classification structure will satisfy the needs of both.

Another frequent factor that has caused variation in past land use classification systems is the difference in the data processing methods used in different cities. Planning offices in some cities do not yet have access to automatic data processing equipment and at present use a simpler, more general system of data collection and analysis than in cities where analysis of detailed data are facilitated by such equipment.

Do these types of local factors mean then that the whole idea of developing a standard system for describing land use activity in a comparable form from city to city is a lost cause? Not at all. What it does mean is that if there is to be comparability, there must be an approach to classifying land use activity that will permit *standardization in coding land use activity data and flexibility in the use of the data once it is coded*. This only can be accomplished if land use activity is identified and coded at a fairly detailed level.

Seldom will it be necessary or even desirable in any day-to-day planning operation to work with land use activity data at the detailed level being recommended for data collection and coding (i.e., the four-digit level of detail listed in ch. IV). However, if land use activity is identified and coded using the four-digit codes, the data can then be regrouped into a variety of different classification patterns to fit the needs of special studies and analyses.

The cost of recording and coding land use information at the four-digit level of detail will usually be greater than if the data were recorded and coded at more generalized levels. This extra cost comes from the additional detail in which land uses must be identified in the field inventory and also from the additional effort required in coding the collected data. On the other hand, such extra costs often can be offset by the greater flexibility and wider utilization of the data.

As indicated in the Foreword, the question of the level of detail at which a community should inventory and record its land use information must be decided locally, giving consideration to the numerous factors involved. It should be recognized that if land use activity information is recorded and coded only at one of the more generalized levels shown in chapter IV, say at the one-, two-, or three-digit levels of detail, this will reduce many possible uses for the data. Even so, there still is an advantage in using the standard land use coding system at the more generalized levels, since these codes will still be comparable with other studies using the same system.

The list of activity categories and their numeric codes shown in chapter IV are arranged in a hierarchical order of generalization. The nine major classifications of land use recommended here are considered to be the most useful to a wide range of planning studies. However, the emphasis in this system of categories is not on the classification structure, but on the detailed identification of land use activity (i.e., the four-digit level of detail listed in ch. IV). Emphasis is also placed on the preservation of these detailed data in a form that will allow them to be conveniently and efficiently arranged into a variety of possible classifications in order to satisfy local planning requirements.

### C. THE NEXT STEP

Over the next few years the proposed system of land use activity categories is

expected to be used in a variety of urban development and transportation planning studies to test and refine the system. Categories may be added, changed, or reworded in order to make them more precise and operational. As field tests demonstrate the need for change, revisions of the system will be incorporated in subsequent editions of this publication.

Since this is the initial publication of the *Standard Land Use Coding Manual*, the Urban Renewal Administration and the Bureau of Public Roads invite comments, observations, and suggestions. These will be appreciated and given full consideration in future editions of this report. Please address all comments to:

Office of Urban Planning and Community Development  
Urban Renewal Administration  
Housing and Home Finance Agency  
Washington, D.C. 20410  
or  
Urban Planning Division  
Bureau of Public Roads  
Department of Commerce  
Washington, D.C. 20235



### ***III Use of the Categories***

#### **A. DESCRIPTION AND RATIONALE**

There are several facets of this coding system that should be explained to insure that the categories are properly understood and correctly applied.

##### ***1. General Structure***

The standard system for coding land use activity is comprised of 9 one-digit categories (2 of which have been assigned to "manufacturing"), 67 two-digit categories, 294 three-digit categories, and 772 four-digit categories. The categories at the four-digit level identify land use activity in the greatest detail, and as the system is aggregated to the three-, two-, and one-digit levels the categories become more generalized. The structure of this classification system, therefore, permits an agency to select the level of detail considered most appropriate for analysis and presentation of its data.

---

The categories at the one-digit level of generalization are:

<i>Code</i>	<i>Category</i>	<i>Code</i>	<i>Category</i>
1	Residential.	7	Cultural, entertainment, and recreational.
2 and 3	Manufacturing.	8	Resource production and extraction.
4	Transportation, communication, and utilities.	9	Undeveloped land and water areas.
5	Trade.		
6	Services.		

---

In addition to the above activity categories, this system also includes a series of auxiliary codes that are used to further describe the activity identified. The use of the auxiliary categories is described in the following section of this chapter.

The reader will note that many of the categories shown in chapter IV are repeated at several levels of detail. For example, "Groceries (with or without meat)—retail" is located under code 541, and also under code 5410. A zero in the last digit position will always indicate that the code is repeated from a more general level. This was done either where it was considered unfeasible or unnecessary to identify activity in any greater detail or where it was decided that local field testing was necessary before determining more precisely the individual categories necessary at the three- and four-digit levels of generalization.

If it becomes necessary to further subdivide a category into a finer breakdown of activity than is shown, this can be done within the present system of categories and code numbers by either dropping the zeros to the right and adding digits, or where there are no zeros by adding digits to the right of the present code number. For example, a further breakdown of "Office furniture—manufacturing" (code 2520) and "Motor vehicles and motor vehicle equipment—manufacturing" (code 3441) would be as follows:

<i>Code</i>	<i>Category</i>	<i>Code</i>	<i>Category</i>
2520	Office furniture—manufacturing.	2521	Office furniture (wood)—manufacturing.
		2522	Office furniture (metal)—manufacturing.
3441	Motor vehicles and motor vehicle equipment—manufacturing.	34411	Motor vehicles—manufacturing.
		34412	Passenger car bodies—manufacturing.
		34413	Trucks and bus bodies—manufacturing.
		34414	Motor vehicle parts and accessories—manufacturing.
		34415	Truck trailers—manufacturing.
		34416	Etc.

This procedure permits a logical expansion of any section of the coding system, whether it be manufacturing or recreation codes, where a local planning group finds it necessary to satisfy their unique planning needs.

## 2. *Purpose and Use of the Auxiliary Codes*

There are certain land use activities that are generally found separated from, but are functionally and organizationally linked to other activities. For example:

- a. A warehouse operated by a retail concern primarily for its own use and not for public storage;
- b. A parking area operated by a manufacturing concern for use by its own employees and not for public parking;
- c. An office performing management functions as part of a mining concern which has mines in several States.

These are all important space uses in themselves. However, they are also significant in their relationship to the parent activity they serve.

To illustrate this point further, consider a warehouse located separately from the parent activity it serves, which may be for example, a manufacturer of pharmaceuticals or a department store. This warehouse, during a land use inventory, may be identified and coded *only* as a warehouse. This does not permit linking the warehouse as a facility of the parent activity. It would be equally misleading if the warehouse were to be given the same code as the parent activity with no other identification. Studies of *total space use needs* or planning for the physical needs of a community are handicapped by such limited information.

To provide a link between certain significant auxiliary functions and the parent activities they serve, a series of one-digit "Auxiliary" categories are provided. These should be used with the standard system for coding land use activity. The auxiliary categories are as follows:

<i>Code</i>	<i>Auxiliary categories</i>	<i>Code</i>	<i>Auxiliary categories</i>
0	Not an auxiliary.	5	Automobile parking. <sup>a</sup>
1	Central or administrative office. <sup>4</sup>	6	Motor vehicle garage (maintenance and/or storage of vehicles).
2	Sales office.	7	Steam and power plant.
3	Research and development.	8-9	(Open codes). <sup>b</sup>
4	Warehousing and storage.		

<sup>4</sup> Central or administrative offices are those offices engaged in general administrative, supervisory, purchasing, accounting, or other management functions.

<sup>a</sup> A minimum of 5,000 square feet or approximately 17 parking spaces is necessary before the area can be identified as auxiliary parking area.

<sup>b</sup> Planning agencies desiring to distinguish additional types of auxiliary categories other than those defined (e.g., recreational activities that are subsidiary to or serving another activity) should use open codes 8 and 9.

Codes 1 through 7 should be used when one of the listed activities can be determined to be subsidiary to or serving another activity. For example, if a research and development laboratory of a manufacturer of pharmaceutical preparations is located down the street from the actual manufacturing plant itself, the laboratory would be considered as an auxiliary and would be coded as follows:

<i>Basic activity code</i>	<i>Auxiliary code</i>	<i>Combined activity code</i>
(Pharmaceutical preparations—manufacturing) 2834	(Research and development) 3	2834-3

An automobile parking area over 5,000 square feet which is an adjunct to an activity, e.g., a grocery store, and which is not used for other purposes in the same sense as a public parking area would be coded as follows:

<i>Basic activity code</i>	<i>Auxiliary code</i>	<i>Combined activity code</i>
(Groceries—retail) 5410	(Automobile parking) 5	5410-5

The sales office of a manufacturing concern that is separately located from the actual factory, whether it be next door in a separate building, across the street,

on the other side of the town, or in another city, is considered as serving the manufacturing process. Similarly, the permanent office of a construction company is considered as serving the construction activity. Therefore, these office activities would be coded as follows:

<i>Basic activity code</i>	<i>Auxiliary code</i>	<i>Combined activity code</i>
(Farm machinery and equipment—manufacturing) 3122	(Sales office) 2	3122-2
(Building construction—general contractor services) 6611	(Central or administrative office) 1	6611-1

With respect to wholesaling activity (code 51), those wholesalers *without* stock (i.e., they do not have a definite storage area set aside to maintain a volume of stock on hand) are also considered to be auxiliary, and they are identified by one of the auxiliary codes, accordingly. For example:

<i>Basic activity code</i>	<i>Auxiliary code</i>	<i>Combined activity code</i>
(Fruits and vegetables, fresh—wholesale) 5147	(With stock) 0	5147 0
(Fruits and vegetables, fresh—wholesale) 5147	(Sales office, without stock) 2	5147-2

On the other hand, an independent research, development, and testing laboratory would not be considered as an auxiliary activity, and it would be coded under its respective activity category, code 6391. Parking is coded in a similar way if it is public parking or parking serving more than one concern, such as the parking area of a shopping center. The following examples illustrate this:

<i>Basic activity code</i>	<i>Auxiliary code</i>	<i>Combined activity code</i>
(Research, development, and testing services) 6391	(Not an auxiliary) 0	6391 0
(Automobile parking) 4600	(Not an auxiliary) 0	4600-0

The preceding discussion and illustrations of the use of the auxiliary codes are centered primarily on the problem of preserving the linkage between related activities while at the same time identifying important land uses. It is recognized that for some planning studies, such as open space or recreation planning, the two open codes (8 and 9) may not provide sufficient categories for identifying recreational or open space uses which are a part of some larger activity. If it is found necessary or desirable to identify such related uses, a new and separate series of auxiliary codes should be developed to accommodate the needs of the special study, thereby preserving the original auxiliary codes for comparability over a period of time and between cities.

### 3. *The Use of Standard Industrial Classification Nomenclature*

A commonly used system for identifying economic activity is the *Standard Industrial Classification* (SIC) established and published by the U.S. Bureau of the Budget. This system developed for studying the economic characteristics of our economy is " \* \* \* used in the classification of establishments by type of activity in which engaged; for purposes of facilitating the collection, tabulation, presentation, and analysis of data related to establishments; and for promoting uniformity and comparability in the presentation of statistical data \* \* \* " collected by various government agencies and by private organizations.

Since the SIC is a detailed classification of establishments and because of the wide acceptance of the nomenclature used in the SIC, this land use coding system uses the SIC category titles and the detailed identification of activities as far as is feasible. However, no attempt was made to identify the four-digit land use categories by the same code numbers as the comparable categories in the SIC. It was not considered practical to make the numbers the same since establishments identified by separate code numbers under the SIC have in some instances been combined into one activity description in the four-digit land use codes. In other instances different types of establishments that were grouped under one code in the SIC may have been identified separately under the land use codes, each being given a separate code number. In addition to these differences, many land use activities that need to be identified for planning purposes are not comparable to any SIC industry description, and, therefore, it would still have been necessary to establish new code numbers.

In chapter IV, the SIC codes listed in column 7 are used only as references.<sup>5</sup> That is, these are the codes in the SIC system that generally correspond to the four-digit land use activity listed. It should be recognized, however, *that the adoption of the same terminology does not necessarily make the land use data collected and coded under this system of categories compatible with the economic data collected using SIC specifications.* Differences often arise through the dissimilar criteria used to code activities in the two systems.

Federal agencies using the SIC in their statistical programs, such as the economic censuses of the Bureau of the Census, the Bureau of Employment Security, the Bureau of Labor Statistics, and the Bureau of Old Age and Survivors Insurance, obtain information *directly* from an "establishment" in terms of either the value of products produced, value of construction or work done, value of products sold, or value of receipts for services rendered depending upon the economic sector in which the establishment is located. The establishment is then assigned an SIC code on the basis of its *major* activity as measured by *the value of the product or services offered.* In an establishment concerned with only one product or service, there is no problem in assigning the SIC code. However, where there is a mixture of several products or services, the establishment is assigned

<sup>5</sup> *Standard Industrial Classification Manual*, prepared by Bureau of the Budget, U.S. Government Printing Office, Washington, D.C., 1957, p. 1.

<sup>6</sup> The SIC code numbers shown in ch. IV are from the *Standard Industrial Classification Manual* identified in footnote 7 and from the *Standard Industrial Classification Manual—Supplement to 1957 Edition*, prepared by the Bureau of the Budget, U.S. Government Printing Office, Washington, D.C., 1963.

only the code of that product or service that results in the largest percentage of total value.

The term "establishment" used by these agencies in general denotes an "economic unit which produces goods or services— for example, a farm, a mine, a factory, a store. In most instances, the establishment is at a single physical location, and it is engaged in only one, or predominantly one type of economic activity for which an industry code is applicable."<sup>3</sup>

In contrast to the above, in most planning studies land use activity is identified through one of three different criteria and procedures: (a) through observation, (b) through interviews, or (c) through the use of secondary data sources, e.g., insurance maps or assessors' records. Also, where there is a mixture of several activities on the same premises, the activity taking up the *greatest amount of space* is the one normally identified and coded.

Since the unit of collection in land use inventories is not based on the same "establishment" concept as defined in the SIC, and since land use activities are not classified according to the value of the product or service, the same establishment could easily be identified differently under the two systems.

As a result of these differences, economic data collected and coded using the SIC categories will not always be comparable with the land use data identified under the standard land use coding system. This will be especially true of land use activities identified at the very detailed three- and four-digit levels. Where classes of land use activity are summarized to a more generalized level, say at the two-digit level, the respective items of information can be more favorably compared. However, even at this level of generalization, a certain amount of discrepancy will still occur. If information obtained from the two systems are to be used together, the actual areas of differences should be determined, and appropriate procedures should be developed for reconciling these statistical categories.

#### 4. Coding Ownership

The proposed system of categories identifies only the activity without regard to whether it is "publicly" or "privately" owned. If this further description of an activity is desired, a separate series of classifications should be developed. The subdivisions under ownership may simply differentiate between "public" and "private" activity, or it may have further subdivisions of these two basic categories. One such series of categories recommended for use by local communities is presented in appendix 1.

Under the system of land use activity identification proposed in this manual, the coding of governmental activities has been approached in two different ways. "Executive, legislative, and judicial functions" (code 671); "Protective functions and their related activities" (code 672); "Postal services" (code 673); "Correctional institutions" (code 674); and "Military bases and reservations" (code 675) are considered to be "Services" and, therefore, coded under this major category. As used here "Executive, legislative, and judicial functions" include only the central and administrative *office* activities of the agencies or special authorities involved in governmental functions, as well as the legislatures and the courts. On the other hand, all operational activities of government (e.g., ship-building, schools, or hospitals) are identified under their respective activity

<sup>3</sup> *Standard Industrial Classification Manual*, p. 2.

categories. In each case, if ownership of the activity is to be distinguished, it should be done through the use of a separate series of categories.

Figure 2 in part B of this chapter is a generalized example of how these two characteristics of land use (activity and ownership) could be recorded and coded. Code 20 in column 7 identifies private activity while codes 11 and 15 indicate public activity, Federal and municipal, respectively.

### 5. Coding Rural Activities

This land use coding system has been developed primarily for use in urban area planning. However, this system is sufficiently broad and flexible enough for use in studies of the urban-rural fringe and of rural areas. Such studies would not require a new system of categories. This flexibility exists in the three- and four-digit levels of detail found under such categories as "Agriculture" and "Agricultural related activities" (codes 81 and 82) and "Commercial forestry production" (code 831). Where such three- and four-digit detail for rural land uses is not needed, these activities can be recorded in more general categories at the two-digit level.

A special series of "Farm use" categories is also provided for those who may wish to analyze agricultural activity in even greater detail, i.e., either by types of farms or by the different uses made of the area within farms. The system of "Farm use" categories and their use are explained in appendix 2.

### 6. Rationale Behind Some of the Categories

#### a. Household units.

The term "Household units" (code 11) is used in this coding system to prevent confusion with the types of living quarters enumerated by the Bureau of the Census. Although the definition used to identify the "Household units" is very similar to the term "Housing unit" used by the Census, the major differences between the two are in the treatment of "Residential hotels" (code 13) and "Mobile home parks or courts" (code 14). These two categories which are included in the Census term "Housing unit" are excluded from "Household units" and listed as separate categories in the coding system.

A "Household unit" identifies only one residential unit whether it be in a single family home, in an apartment house, or over a grocery store. Such descriptive characteristics as the number of "Household units" within a structure or the type of residential structure (e.g., single family detached or apartment) have not been incorporated into the basic land use activity categories since they are considered descriptions that should be recorded and coded as separate items in the information file.

As previously indicated, information about such separate characteristics can be collected at the same time that the land use inventory is made. Figure 3 in part B of this chapter is a general example illustrating a method for recording and coding (1) residential activity, (2) type of residential structure, and (3) number of "Household units."

The major advantage in following the procedure illustrated in figure 3 is the flexibility afforded in the use of the collected residential information. Instead of a limited classification system indicating a range in the number of units (i.e., 3 to 4 "Household units," 5 to 10 "Household units," etc.), there would be available a specific count of the units. Also, by using a separate series of

descriptions for types of residential structures, the categories would be more precise and, therefore, more meaningful and useful. One such series of categories recommended for use by local communities is shown in appendix 3.

If a planning agency desires to incorporate a description of structure types into the basic activity coding system, the categories shown in appendix 3 can also be used to serve this purpose. Columns 1 and 2 in appendix 3 (the code number and the category) would become a series of three-digit categories under "Household units" and columns 3 and 4 would become the four-digit categories. In each case, the code numbers in the appendix would replace the zeros in the basic activity codes as follows:

		<i>Present Codes</i>			
<i>Code</i>	<i>Category</i>	<i>Code</i>	<i>Category</i>	<i>Code</i>	<i>Category</i>
11	Household units	110	Household units	1100	Household units
<i>After Change</i>					
11	Household units	111	Single family structures	1111	Single units detached
				1112	Single units semidetached
				1113	Etc.

#### b. Manufacturing categories.

The number of categories and type of detail distinguished under "Manufacturing" (codes 2 and 3) exceed those of any other land use activity. The major purpose for maintaining this amount of detail is that each of the industrial activities identified under "Manufacturing" is not found in each of our urban areas as are activities such as police stations, real estate offices, or women's apparel shops.

Community "A" may contain five or six types of manufacturing industries. Community "B" may also have five or six types of manufacturing industries. However, the industries located in community "B" may be quite different than those in community "A." Since this system will be used throughout the United States, and since each community will desire to identify specifically those manufacturing activities located within its study limits, a detailed breakdown of manufacturing is necessary, recognizing, however, that not all of the detailed manufacturing categories will be used in any single community.

#### c. Warehousing and storage categories.

Warehousing and storage areas are handled in one of two ways. As indicated in section A2 of this chapter, a warehouse or storage area not in the same building as the parent establishment is identified with the basic code of the parent activity and the auxiliary code of 4. For example:

<i>Basic activity code</i>	<i>Auxiliary code</i>	<i>Combined activity code</i>
(Department stores - retail)	(Warehousing and storage)	
5310	4	5310 4

On the other hand, a warehouse or storage area that is generally used by the public is coded one of the seven categories under "Warehousing and storage services" (code 637). For example:



<i>Basic activity code</i> (Household goods warehousing and storage)	<i>Auxiliary code</i> (Not an auxiliary)	<i>Combined activity code</i>
6375	0	6375 0
<i>Basic activity code</i> (Farm products warehousing and storage—excluding stock- yards)	<i>Auxiliary code</i> (Not an auxiliary)	<i>Combined activity code</i>
6371	0	6371-0

d. Undeveloped and unused land.

“Undeveloped and unused land area—excluding noncommercial forest development” (code 9100) identifies those parcels of land that appear to be undeveloped or, if previously developed, are presently vacant and unused. This category includes such areas as vacant lands that were once farms located in the rural-urban fringe, as well as vacant parcels where structures have been demolished. “Noncommercial forest development” (code 92) was excluded from code 9100 and made a separate category because of the increasing importance of these areas to government programs concerning “open spaces” and outdoor recreation, as well as statewide planning programs.

e. Vacant floor area.

The category “Vacant floor area” (code 9400) identifies only vacated *nonresidential* floor area within a structure. No provision has been made in the activity coding system for identifying vacant residential units. However, if a distinction is needed between occupied and unoccupied “Household units,” this information can be collected and coded in the same manner as total “Household units.” For example:

<i>Basic activity code</i> (Household units)	<i>Auxiliary code</i> (Not an auxiliary)	<i>Total household units</i> (10 units)	<i>Total vacancies</i> (2 vacancies)	<i>Combined code description</i>
1100	0	10	2	1100-0-10-2

Figure 3 is an example of how vacant-nonresidential floor area within a building containing other activities would be identified and coded. The use of code 9400 alone for a parcel of land would be interpreted as a vacant building.

f. Under construction categories.

“Under construction” (code 95) is a category indicating a temporary stage of land use. The category should be changed when the land use activity information is updated or when sufficient information to identify the activity is available. “Under construction (residential)” (code 9510) is used only when the criteria for completed residential units has not been met.<sup>10</sup> The category of “Under construction (nonresidential)” (code 9520) is used if there is no means of determining what activities will occupy a building when it is completed.

<sup>10</sup> See ch. IV, footnote 5 under code 9510 for the criteria of a completed residential unit.

descriptions for types of residential structures, the categories would be more precise and, therefore, more meaningful and useful. One such series of categories recommended for use by local communities is shown in appendix 3.

If a planning agency desires to incorporate a description of structure types into the basic activity coding system, the categories shown in appendix 3 can also be used to serve this purpose. Columns 1 and 2 in appendix 3 (the code number and the category) would become a series of three-digit categories under "Household units" and columns 3 and 4 would become the four-digit categories. In each case, the code numbers in the appendix would replace the zeros in the basic activity codes as follows:

		<i>Present Codes</i>			
<i>Code</i>	<i>Category</i>	<i>Code</i>	<i>Category</i>	<i>Code</i>	<i>Category</i>
11	Household units	110	Household units	1100	Household units
<i>After Change</i>					
11	Household units	111	Single family structures	1111	Single units detached
				1112	Single units semidetached
				1113	Etc.

#### b. Manufacturing categories.

The number of categories and type of detail distinguished under "Manufacturing" (codes 2 and 3) exceed those of any other land use activity. The major purpose for maintaining this amount of detail is that each of the industrial activities identified under "Manufacturing" is not found in each of our urban areas as are activities such as police stations, real estate offices, or women's apparel shops.

Community "A" may contain five or six types of manufacturing industries. Community "B" may also have five or six types of manufacturing industries. However, the industries located in community "B" may be quite different than those in community "A." Since this system will be used throughout the United States, and since each community will desire to identify specifically those manufacturing activities located within its study limits, a detailed breakdown of manufacturing is necessary, recognizing, however, that not all of the detailed manufacturing categories will be used in any single community.

#### c. Warehousing and storage categories.

Warehousing and storage areas are handled in one of two ways. As indicated in section A2 of this chapter, a warehouse or storage area not in the same building as the parent establishment is identified with the basic code of the parent activity and the auxiliary code of 4. For example:

<i>Basic activity code</i>	<i>Auxiliary code</i>	<i>Combined activity code</i>
(Department stores - retail)	(Warehousing and storage)	
5310	4	5310 4

On the other hand, a warehouse or storage area that is generally used by the public is coded one of the seven categories under "Warehousing and storage services" (code 637). For example:

<i>Basic activity code</i> (Household goods warehousing and storage)	<i>Auxiliary code</i> (Not an auxiliary)	<i>Combined activity code</i>
6375	0	6375 0
<i>Basic activity code</i> (Farm products warehousing and storage—excluding stock- yards)	<i>Auxiliary code</i> (Not an auxiliary)	<i>Combined activity code</i>
6371	0	6371-0

d. Undeveloped and unused land.

“Undeveloped and unused land area—excluding noncommercial forest development” (code 9100) identifies those parcels of land that appear to be undeveloped or, if previously developed, are presently vacant and unused. This category includes such areas as vacant lands that were once farms located in the rural-urban fringe, as well as vacant parcels where structures have been demolished. “Noncommercial forest development” (code 92) was excluded from code 9100 and made a separate category because of the increasing importance of these areas to government programs concerning “open spaces” and outdoor recreation, as well as statewide planning programs.

e. Vacant floor area.

The category “Vacant floor area” (code 9400) identifies only vacated *nonresidential* floor area within a structure. No provision has been made in the activity coding system for identifying vacant residential units. However, if a distinction is needed between occupied and unoccupied “Household units,” this information can be collected and coded in the same manner as total “Household units.” For example:

<i>Basic activity code</i>	<i>Auxiliary code</i>	<i>Total household units</i>	<i>Total vacancies</i>	<i>Combined code description</i>
(Household units) 1100	(Not an auxiliary) 0	(10 units) 10	(2 vacancies) 2	1100-0-10-2

Figure 3 is an example of how vacant-nonresidential floor area within a building containing other activities would be identified and coded. The use of code 9400 alone for a parcel of land would be interpreted as a vacant building.

f. Under construction categories.

“Under construction” (code 95) is a category indicating a temporary stage of land use. The category should be changed when the land use activity information is updated or when sufficient information to identify the activity is available. “Under construction (residential)” (code 9510) is used only when the criteria for completed residential units has not been met.<sup>10</sup> The category of “Under construction (nonresidential)” (code 9520) is used if there is no means of determining what activities will occupy a building when it is completed.

<sup>10</sup> See ch. IV, footnote 5 under code 9510 for the criteria of a completed residential unit.

## B. APPLICATION

### 1. Identifying and Coding Land Use Activities.

A series of examples have been prepared to illustrate and further clarify the application of the land use activity coding system. These examples, although very general, are intended to show at what level of detail land use activity data should be collected in order to obtain the maximum benefit of the coding system.

Figures 2, 3, 4, and 5 are examples of how activities might be identified and described in a field inventory and then coded back at the office. Section A of each figure shows the parcel and structures (marked with an X) which are being inventoried. Section B shows a schematic version of the structure(s) on each parcel with the type of activities on each floor. Section C is a portion of a field listing form on which the information will be recorded and then coded. Columns (1) through (4) on the field listing form are used to record the location of the activity, column (5) is used to describe the activity, and column (6) is used by a field lister to indicate whether or not the activity being identified is an auxiliary. An X in this column denotes that the activity is an auxiliary, and a dash denotes that it is not.

In figure 3, there are several "Household units" located at 516 Silver Lane. Where there is more than one unit in a structure, the description (Household units) need be recorded only once as shown in column 5 and the number of units listed separately as shown in column 9. Columns 8 and 8' indicate how the type of residential structure can be recorded and coded whenever a "Household unit" is identified.

Figure 5 illustrates the treatment of a parcel of land occupied by a furniture manufacturer and its related activities. The administrative offices are located in a separate structure and, therefore, are identified as a separate but auxiliary activity. The parcel also has a defined off-street parking area that is used only by factory employees, so this too is identified as a separate but auxiliary activity.

In figures 2 through 5 each of the establishments identified is engaged in only one type of basic activity. If, however, there had been an establishment that conducted several separate activities (not auxiliary activities) within the same physical premises, e.g., a clothing manufacturer with a small retail outlet, only the activity occupying the largest floor area would be identified. Predominant floor area for activities in a structure or predominant land area for activities not in a structure will determine the activity that is coded.

With the collection, identification, and coding of the data to a four-digit level of detail (plus the use of auxiliary codes), a basic reservoir of information has been established. This information may be stored on data processing cards or on computer tapes. Where electronic data processing or computer equipment is not available, the data may remain in land use listing forms. In any case, the detailed activity data are available for use in the proposed classification system or as individual categories for regrouping into other classes.

### 2. Standardization and Flexibility.

Even though the nine basic activity classifications shown in chapter IV are expected to be helpful to a wide range of studies, there will be times when planning situations or preferences will call for groupings or combinations of categories differing from those proposed here. One of the best examples of

Figure 2. Example: Describing and Coding Activities

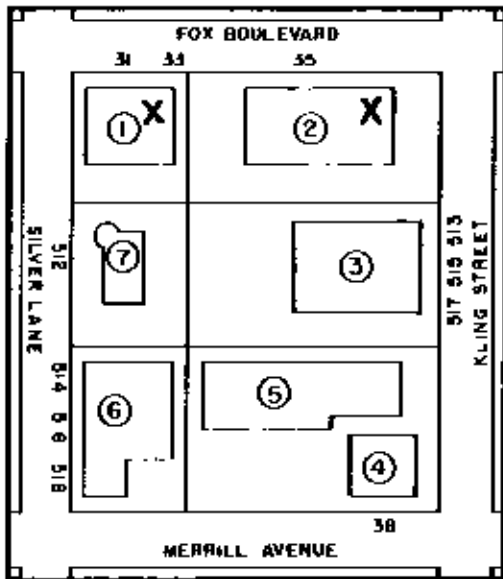

2A Block Plan

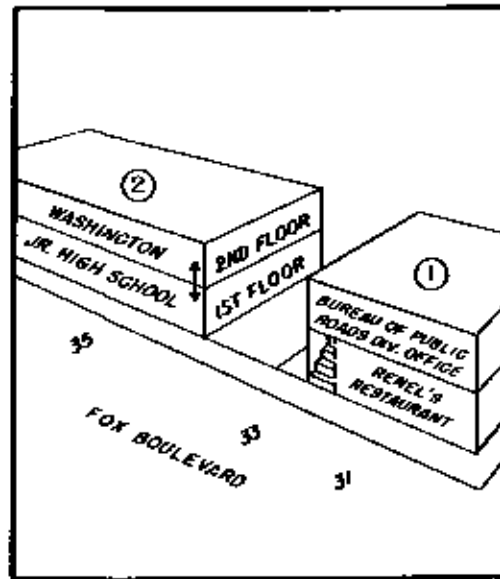

2B—Parcel Schematic

Serial No.	Street Name	Building No.	Floor	FIELD OPERATION				OFFICE OPERATION						
				Description of Activity	Auxiliary?	Activity Ownership	Residential Structure Type	No. of House-hold Units	Activity Code	Auxiliary Code	Ownership Code	Structure Code	No. of House-hold Units	
1	2	3	4	5	6	7	8	9	10	11	12	13	14	15
31	FOX BOULEVARD	1	1	RENEL'S RESTAURANT	—	PRIVATE	—	—	5810	0	20	—	—	—
33	FOX BOULEVARD	1	2	BUREAU OF PUBLIC ROADS, DIVISION OFFICE'S (ADMIN.)	X	FEDERAL	—	—	6710	1	11	—	—	—
35	FOX BOULEVARD	2	1, 2	WASHINGTON JUNIOR HIGH SCHOOL (GRADES 7-9)	—	MUNI-CIPAL	—	—	6813	0	15	—	—	—

2C.—Example of Land Use Entries on a Field Listing Form

Figure 3.—Example: Describing and Coding Activities

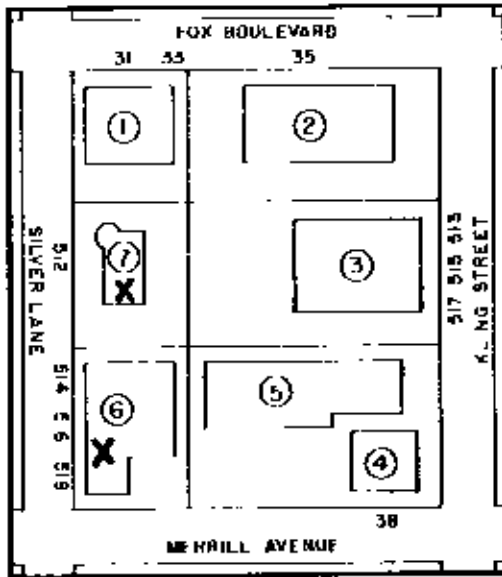

3A—Block Plan

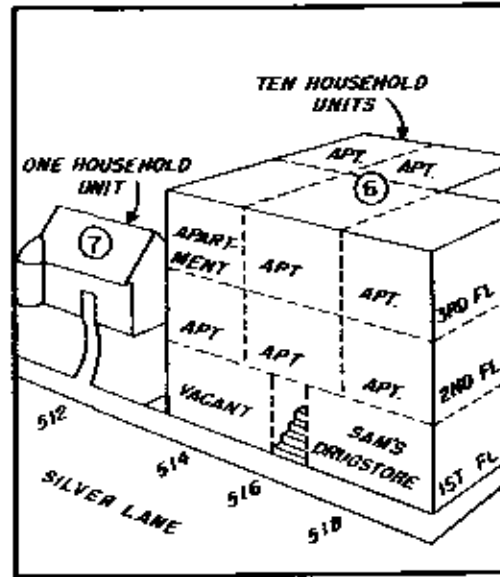

3B—Parcel Schematic

FIELD OPERATION									OFFICE OPERATION				
Street No.	Street Name	Building No.	Floor	Description of Activity	Auxiliary	Activity Ownership	Residential Structure Type	No. of Equival. Units	Activity Code	Auxiliary Code	Ownership Code	Structure Code	No. of Square Feet
1	2	3	4	5	6	7	8	9	10	11	12	13	14
518	SILVER LANE	6	1	SAM'S DRUG STORE		PRIVATE			5910	0	20		
516	SILVER LANE	6	2+3	HOUSEHOLD UNITS		PRIVATE	WALK-UP APART.	10	1100	0	20	31	10
514	SILVER LANE	6	1	VACANT FLOOR AREA					9400	0			
512	SILVER LANE	7	1	HOUSEHOLD UNITS		PRIVATE	SINGLE UNIT DETACHED	1	1100	0	20	11	01

3C. Example of Land Use Entries on a Field Listing Form

Figure 4. —Example: Describing and Coding Activities

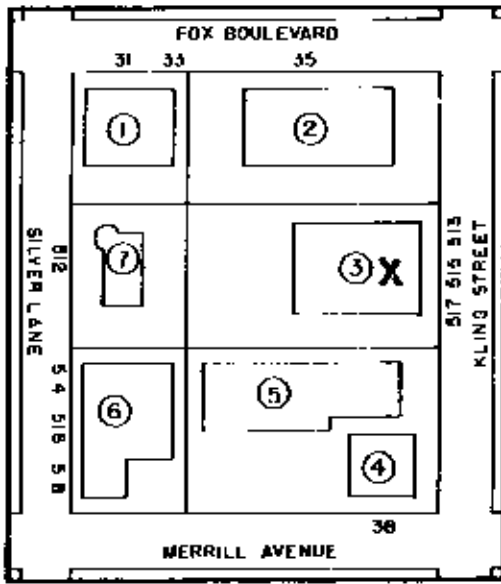

4A—Block Plan

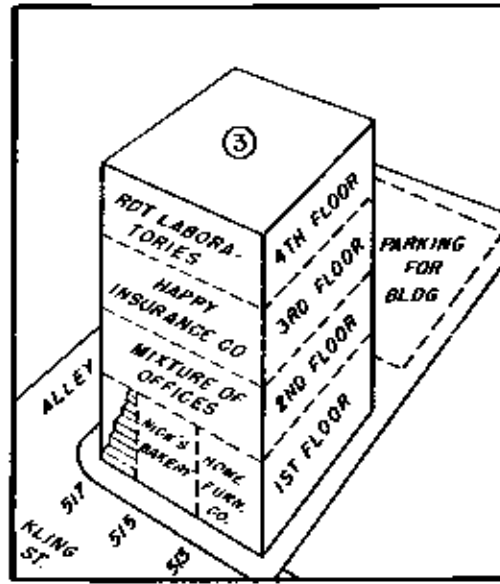

4B—Parcel Schematic

Block No.	Street Name	Building No.	Floor	FIELD OPERATION					OFFICE OPERATION				
				Description of Activity	Auxiliary?	Activity Ownership	Residential Structure Type	No. of House-hold Units	Activity Code	Auxiliary Code	Ownership Code	Structure Code	No. of House-hold Units
1	2	3	4	5	6	7	8	9	10	11	12	13	14
513	KLING ST.	3	1	HOME FURNITURE CO. (RETAIL)	—	PRIVATE	—	—	5711	0	20	—	—
515	KLING ST.	3	1	NICK'S BAKERY (WITH OVEN IN REAR)	—	PRIVATE	—	—	5461	0	20	—	—
517	KLING ST.	3	2	BIG TOWN REAL ESTATE CO. (REAL ESTATE AGENTS & BROKERS OFFICES)	—	PRIVATE	—	—	6152	0	20	—	—
511	KLING ST.	3	2	PHYSICIAN'S OFFICE	—	PRIVATE	—	—	6511	0	20	—	—
517	KLING ST.	3	2	JONES CHEMICAL CORP. (SALES OFF. OF AGRICULTURAL FERTILIZER MFG.)	X	PRIVATE	—	—	2870	2	20	—	—
517	KLING ST.	3	2	ADAM CONSTRUCTION CO. (GENERAL OFFICES - HOME BUILDERS)	X	PRIVATE	—	—	6611	1	20	—	—
517	KLING ST.	3	2	LAW FIRM (OFFICES)	—	PRIVATE	—	—	6520	0	20	—	—
517	KLING ST.	3	3	HAPPY INSURANCE CO. (REGIONAL OFFICE OF COMPANY)	X	PRIVATE	—	—	6141	1	20	—	—
511	KLING ST.	3	4	RDT LABORATORIES (DEVELOPMENT LABORATORIES FOR RDT INDUSTRIES - RADIO TRANSMITTING EQUIPMENT MFG.)	X	PRIVATE	—	—	3436	3	20	—	—
513-511	KLING ST.	—	—	PARKING FOR VISITORS & EMPLOYEES IN THE REAR (20 SPACES)	—	PRIVATE	—	—	4600	0	20	—	—

4C—Example of Land Use Entries on a Field Listing Form

Figure 5. -Example: Describing and Coding Activities

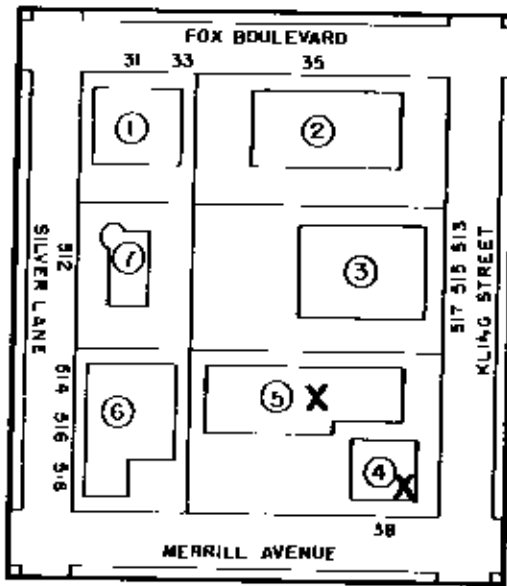

5A—Block Plan

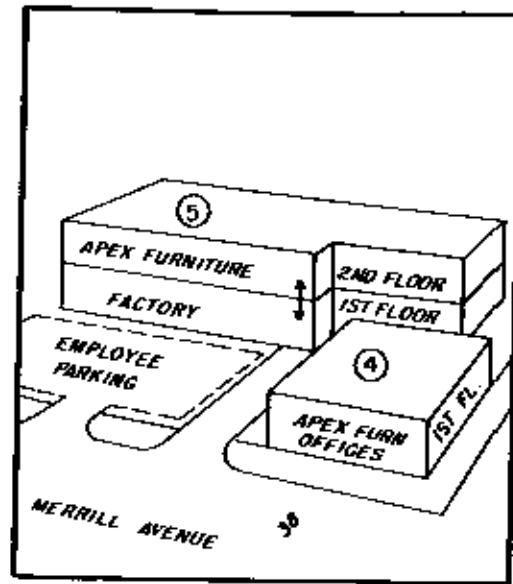

5B Parcel Schematic

Block No.	Street Name	Building No.	Floor	FIELD OPERATION					OFFICE OPERATION				
				Description of Activity	Auxiliary?	Activity Ownership	Residential Structure Type	No. of Houses Sold This	Activity Code	Auxiliary Code	Structure Code	Structure Code	No. of Houses Sold This
1	2	3	4	5	6	7	8	9	5'	6'	7'	8'	9'
38	MERRILL AVE.	4	1	APEX FURNITURE FACTORY (ADMINISTRATIVE OFFICES OF FACTORY)	X	PRIVATE			2520	1	20		
38	MERRILL AVE.	5	1	APEX FURNITURE FACTORY (FACTORY PRODUCING WOOD OFFICE FURNITURE)		PRIVATE			2520	0	20		
38	MERRILL AVE.			APEX FURNITURE FACTORY (EMPLOYEE PARKING—36 SPACES)	X	PRIVATE			2520	5	20		

5C—Example of Land Use Entries on a Field Listing Form



this is in a metropolitan area where there are numerous local governments, many with their own planning offices. Past experience has shown that these offices have their own unique preferences concerning an activity classification system. Hence, it becomes extremely difficult to establish a compromise classification system that is acceptable to all parties concerned.

One answer to this problem is to inventory land use activity for the entire metropolitan area and to code the data using the four-digit standard land use coding system presented in chapter IV. This will establish a common base of detailed activity data that have the same standard identification and code number throughout the metropolitan area. Since each land use activity is now specifically identified, classifications of activity can be arranged to fit most analyses or special studies simply by a regrouping of the detailed categories. Hence, from this common base, each planning group within the metropolitan area can develop its own combination of categories and still maintain comparability with each of the other communities.

Thus, a major advantage of the proposed land use activity coding system is that it will permit a standardization of activity categories and code numbers, and at the same time through the use of electronic data processing equipment and electronic computers, it will also permit the reorganization of these detailed categories to classifications that may be more useful to the individual local communities. The small community of under 50,000 population and the large metropolitan area can both observe the same basic principles proposed here and have a common basis for comparing land use activity data. Tables 1 and 2 show the types of classifications that can be developed once the detailed data have been collected and coded to a common base.

Table 1 illustrates how a new classification such as "Offices" can be developed. In this example, all those activities that have been identified with an auxiliary code of 1 or 2 (central administrative offices and sales offices) have been grouped with all other "office type" activities. Since each category of activity that goes into making up the new classification of "Offices" is specified, the local community can now determine the percent that each office type category represents of the total office space identified. If this information were updated from time to time, the general trend in office space usage could be determined.

Table 2 illustrates how three different types of studies could take the same basic land use activity data (collected and coded to the four-digit level of the standard land use coding system) and recombine the categories in order to organize the data into classifications that will best fit the purposes of each study. In each case special code numbers will have to be established locally to identify the new classifications.

Throughout this report emphasis has been placed on identifying and coding to the four-digit level of detail in order to establish a common base of information. This does *not* mean that land use cannot be collected and coded to the three-, two-, or one-digit levels of generalization, if this should be desired. However, if data are collected and coded at these more general levels, it should be recognized that flexibility in the use of the data coded will also be substantially reduced.

TABLE 1.—AN EXAMPLE OF THE USE OF THE STANDARD LAND USE CODING SYSTEM FOR DEVELOPING NEW CLASSIFICATIONS

<i>Local code no.</i>	<i>New classification</i>	<i>Code</i>	<i>Categories from the standard land use coding system</i>
			All land use activities with a 1 or 2 in the auxiliary position, plus the following categories:
		611	Banking and bank-related functions.
		6122	Agricultural, business, and personal credit services (including credit unions).
		6129	Other credit services (other than banks) NEC.
		613	Security and commodity brokers, dealers, exchanges, and services.
		614	Insurance carriers, agents, brokers, and services.
		615	Real estate and related services.
		616	Holding and investment services.
		6311	Advertising services (general).
		632	Consumer and mercantile credit reporting services; adjustment and collection services.
		6331	Direct mail advertising services.
		6339	Stenographic services and other duplicating and mailing services, NEC.
		635	News syndicate services.
		636	Employment services.
		6392	Business and management consulting services.
		6393	Detective and protective services.
		6398	Motion picture distribution and services.
		6511	Physicians' services.
		6512	Dental services.
		652	Legal services.
		659	Other professional services, NEC.
		671	Executive, legislative, and judicial functions.
		699	Other miscellaneous services, NEC.
	<b>Offices</b>		
	This summary classification is developed by combining the following categories:		
<i>Locally determined</i>			

If a land use inventory records and codes data at a more generalized level of detail than the four-digit level, it will not be possible to determine whether a specific activity (which is included in the more generalized classification) is actually taking place in the study area. For example, if "Cultural, entertainment, and recreational" activities are identified and coded at the one-digit level, it will not be possible to determine from the data file whether the study area contains a planetarium, an amphitheater, or a race track.

In addition to this, if a study group decides to make planning studies calling for different classifications of the data collected, it will be restricted in the regrouping of the data to the generalized classifications already coded. While this may seem an obvious point, it is stressed here since this may be a critical decision in planning the land use inventory.



Public assembly, miscellaneous purposes . . . . .	723.
Eating and drinking . . . . .	58.
Bowling . . . . .	7417.
Gymnasiums and athletic clubs . . . . .	7425.
Parks (leisure and ornamental) . . . . .	762.
Vacant or Unused:	
Undeveloped and unused land area . . . . .	91.
Water areas . . . . .	93.
Vacant floor area . . . . .	94.
Under construction . . . . .	95.

Public and Quasi-public:	
Hospitals and medical clinics . . . . .	6513 and 6517.
Government protective services . . . . .	672.
Postal services . . . . .	675.
Correctional institutions . . . . .	674.
Educational services . . . . .	68.
Religious activities . . . . .	691.
Cultural activities . . . . .	711.
Military Bases and Reservations . . . . .	675.
Entertainment and Recreation:	
Nature exhibitions . . . . .	712.
Public assembly . . . . .	72.
Amusements . . . . .	73.
Recreational activities . . . . .	74.
Parks . . . . .	76.
Agricultural, Mining, and Undeveloped Areas:	
Agriculture . . . . .	81.
Mining . . . . .	85.
Commercial and noncommercial forested areas . . . . .	831 and 922.
Undeveloped and unused land area . . . . .	91.
Water areas . . . . .	93.
Vacant floor area . . . . .	94.

Leisure:	
Entertainment assembly . . . . .	721.
Sports assembly and activities . . . . .	722, 741, and 743.
Amusements . . . . .	73.
Parks and reserves . . . . .	76 and 921.
Agricultural and Open Areas:	
Agriculture . . . . .	81.
Commercial forestry production and nonreserve forests (undeveloped) . . . . .	831 and 922.
Undeveloped and unused land area . . . . .	91.
Water areas . . . . .	93.

This table is for illustration purposes only. The combination of categories under each of the 3 types of planning studies are not to be considered the recommended categories for these studies.

## ***IV The Categories and Code Numbers***

### **A. A STANDARD SYSTEM FOR IDENTIFYING AND CODING LAND USE ACTIVITIES—ONE- AND TWO-DIGIT LEVELS**

<i>Code</i>	<i>Category</i>	<i>Code</i>	<i>Category</i>
1	Residential.	11	Household units.
		12	Group quarters.
		13	Residential hotels.
		14	Mobile home parks or courts.
		15	Transient lodgings.
		19	Other residential, NEC <sup>1</sup>
2	Manufacturing.	21	Food and kindred products—manufacturing.
		22	Textile mill products—manufacturing.
		23	Apparel and other finished products made from fabrics, leather, and similar materials—manufacturing.
		24	Lumber and wood products (except furniture)—manufacturing.
		25	Furniture and fixtures—manufacturing.

<sup>1</sup> NEC—Not elsewhere coded.

<i>Code</i>	<i>Category</i>	<i>Code</i>	<i>Category</i>
2	Manufacturing.	26	Paper and allied products—manufacturing.
		27	Printing, publishing, and allied industries.
		28	Chemicals and allied products—manufacturing.
		29	Petroleum refining and related industries.
3	Manufacturing (continued).	31	Rubber and miscellaneous plastic products—manufacturing.
		32	Stone, clay, and glass products—manufacturing.
		33	Primary metal industries.
		34	Fabricated metal products—manufacturing.
		35	Professional, scientific, and controlling instruments; photographic and optical goods; watches and clocks—manufacturing.
		39	Miscellaneous manufacturing, NEC.
4	Transportation, communication, and utilities.	41	Railroad, rapid rail transit, and street railway transportation.
		42	Motor vehicle transportation.
		43	Aircraft transportation.
		44	Marine craft transportation.
		45	Highway and street right-of-way.
		46	Automobile parking.
		47	Communication.
		48	Utilities.
		49	Other transportation, communication, and utilities, NEC.
5	Trade	51	Wholesale trade.
		52	Retail trade—building materials, hardware, and farm equipment.
		53	Retail trade—general merchandise.
		54	Retail trade—food.
		55	Retail trade—automotive, marine craft, aircraft, and accessories.
		56	Retail trade—apparel and accessories.
		57	Retail trade—furniture, home furnishings, and equipment.
		58	Retail trade—eating and drinking.
		59	Other retail trade, NEC.
6	Services.	61	Finance, insurance, and real estate services.
		62	Personal services.
		63	Business services.
		64	Repair services.
		65	Professional services.
		66	Contract construction services.
		67	Governmental services.
		68	Educational services.
		69	Miscellaneous services.
7	Cultural, entertainment, and recreational.	71	Cultural activities and nature exhibitions.
		72	Public assembly.
		73	Amusements.
		74	Recreational activities.
		75	Resorts and group camps.
		76	Parks.

<i>Code</i>	<i>Category</i>	<i>Code</i>	<i>Category</i>
7	Cultural, entertainment, and recreational Continued.	79	Other cultural, entertainment, and recreational, NEC.
8	Resource production and extraction.	81	Agriculture.
		82	Agricultural related activities.
		83	Forestry activities and related services.
		84	Fishing activities and related services.
		85	Mining activities and related services.
		89	Other resource production and extraction, NEC.
9	Undeveloped land and water areas.	91	Undeveloped and unused land area (excluding noncommercial forest development).
		92	Noncommercial forest development.
		93	Water areas.
		94	Vacant floor area.
		95	Under construction.
		99	Other undeveloped land and water areas, NEC.



**B. A STANDARD SYSTEM FOR IDENTIFYING AND CODING LAND USE ACTIVITIES—TWO-, THREE-, AND FOUR-DIGIT LEVELS**

<i>Code</i>	<i>Category</i>	<i>Code</i>	<i>Category</i>	<i>Code</i>	<i>Category</i>	<i>SIC Reference</i> <sup>1</sup>
11	Household units.	110	Household units.	1100	Household units. <sup>2</sup>	—
12	Group quarters.	121	Rooming and boarding houses.	1210	Rooming and boarding houses. <sup>3</sup>	7021
		122	Membership lodgings.	1221	Fraternity and sorority houses.	<sup>4</sup> Incl. 7041
				1229	Other membership lodgings, NEC. <sup>5</sup>	Incl. 7041
		123	Residence halls or dormitories.	1231	Nurses' homes.	—
				1232	College dormitories.	—
				1239	Other residence halls or dormitories, NEC.	—
		124	Retirement homes and orphanages.	1241	Retirement homes.	—
				1242	Orphanages.	—
		125	Religious quarters.	1251	Convents.	—
				1252	Monasteries.	—
				1253	Rectories.	—
				1259	Other religious quarters, NEC.	—
		129	Other group quarters, NEC.	1290	Other group quarters, NEC.	—
13	Residential hotels.	130	Residential hotels.	1300	Residential hotels. <sup>6</sup>	Incl. 7011
14	Mobile home parks or courts.	140	Mobile home parks or courts.	1400	Mobile home parks or courts.	7031
15	Transient lodgings.	151	Hotels, tourist courts, and motels.	1510	Hotels, tourist courts, and motels.	7011
		159	Other transient lodgings, NEC.	1590	Other transient lodgings, NEC. <sup>7</sup>	—
19	Other residential, NEC.	190	Other residential, NEC.	1900	Other residential, NEC.	—

RESIDENTIAL—1

## FOOTNOTES

<sup>1</sup> The SIC codes are listed for purposes of reference. They are the codes in the SIC system that most nearly correspond to the 4-digit land use activity indicated. (See ch. III, sec. A3, "The Use of Standard Industrial Classification Nomenclature.") A dash indicates that there is no corresponding SIC code.

<sup>2</sup> Code 1100—"Household units" are defined as a house, an apartment, or other group of rooms, or a single room that is intended for occupancy as separate living quarters. Occupants of "Household units" do not live and eat with other persons in the structure (such as in a boarding house), and there is either (1) direct access from the outside or through a common hall, or (2) there is a kitchen or cooking equipment for the exclusive use of the occupants of the unit. The occupants may be a family, a group of unrelated persons, or a person living alone. Mobile homes not in "Mobile home parks or courts" (code 14), but resting on a permanent type of foundation (e.g., a brick or concrete block foundation) are included as well as units that are vacant or that are used on a seasonal basis. Farm homes are also included under "Household units" and should be identified separately from the remainder of the farm which is coded under "Agriculture," code 81.

<sup>3</sup> Code 1210—"Rooming and boarding houses" are those that have 5 or more persons renting rooms, with or without board, and not related to the head or person in charge. Where there are less than 5 roomers, the total quarters are considered as one "Household unit" and is coded 1100.

<sup>4</sup> "Incl. 7041" is an abbreviation which indicates that the 4-digit land use activity category is only one of several categories of establishments that are included under SIC code 7041.

<sup>5</sup> "NEC" is an abbreviation for "not elsewhere coded."

<sup>6</sup> Code 1300—"Residential hotels" are those that have 75 percent or more of the available accommodations occupied by permanent guests (i.e., persons who reside more than 30 days). Hotels with less than 75 percent are included under code 15, "Transient lodgings."

<sup>7</sup> Code 1590—"Other transient lodgings, NEC" includes such establishments as the YMCA, YWCA, and YMHA when 50 percent or more of the floor area is devoted to lodging and associated activities and when less than 75 percent of the accommodations are occupied by permanent guests. If 75 percent or more of the guests are permanent, use code 1300. If 50 percent or more of the floor area is devoted to recreational activity, use code 7424, "Recreation centers (general)."

LEVELS—Continued

<i>Code</i>	<i>Category</i>	<i>Code</i>	<i>Category</i>	<i>Code</i>	<i>Category</i>	<i>SIC Reference</i> <sup>1</sup>
21	Food and kindred products—manufacturing.	211	Meat products—manufacturing.	2111	Meat packing—manufacturing.	2011
				2112	Sausages and other prepared meat products—manufacturing.	2013
				2113	Poultry and small game dressing and packing.	2015
		212	Dairy products—manufacturing.	2121	Creamery butter—manufacturing.	2021
				2122	Cheese, natural and processed.	2022
				2123	Condensed and evaporated milk—manufacturing.	2023
				2124	Ice cream and frozen desserts—manufacturing.	2024
				2125	Fluid milk processing.	2026
		213	Canning and preserving of fruits, vegetables, and seafoods.	2131	Canning and curing seafoods.	2031
				2132	Canning specialty foods.	2032
				2133	Canning fruits, vegetables, preserves, jams, and jellies.	2033
				2134	Drying and dehydrating fruits and vegetables.	2034
				2135	Pickling fruits and vegetables; vegetable sauces and seasonings; salad dressings—manufacturing.	2035
				2136	Fresh or frozen packaged fish and seafoods.	2036
				2137	Frozen fruits, fruit juices, vegetables, and specialties.	2037
		214	Grain mill products—manufacturing.	2141	Flour and other grain mill products.	2041
				2142	Preparing feeds for animals and fowls.	2042
				2143	Cereal preparations.	2043
				2144	Rice milling.	2044

	2146	Wet corn milling.	2046
215		Bakery products—manufacturing.	205
216		Sugar—manufacturing.	206
217		Confectionery and related products—manufacturing.	2071
	2172	Chocolate and cocoa products—manufacturing.	2072
	2173	Chewing gum—manufacturing.	2073
218		Beverage—manufacturing.	2082
	2181	Malt liquors—manufacturing.	2083
	2182	Malt—manufacturing.	2084
	2183	Wine, brandy, and brandy spirits—manufacturing.	2085
	2184	Distilling, rectifying, and blending liquors.	2086
	2185	Bottling and canning soft drinks and carbonated waters.	2087
	2186	Flavor extracts and flavoring syrups manufacturing, NEC.	2091
219		Other food preparations and kindred products manufacturing, NEC.	2092
	2191	Cottonseed oil milling.	2093
	2192	Soybean oil milling.	2094
	2193	Vegetable oil milling (except cottonseed and soybean).	2095
	2194	Animal and marine fats and oils (including grease and tallow)—manufacturing.	2096
	2195	Roasting coffee and coffee products—manufacturing.	2097
	2196	Shortening, table oils, margarine, and other edible fats and oils—manufacturing.	2098
	2197	Ice—manufacturing.	2099
	2198	Macaroni, spaghetti, vermicelli, and noodles—manufacturing.	
	2199	Other food preparations and kindred products manufacturing, NEC.	

**B. A STANDARD SYSTEM FOR IDENTIFYING AND CODING LAND USE ACTIVITIES—TWO-, THREE-, AND FOUR-DIGIT LEVELS—Continued**

<i>Code</i>	<i>Category</i>	<i>Code</i>	<i>Category</i>	<i>Code</i>	<i>Category</i>	<i>SIC Reference</i>
22	Textile mill products—manufacturing.	221	Broad and narrow woven fabrics and other smallwares (cotton, manmade fibers, silk, and wool)—manufacturing.	2210	Broad and narrow woven fabrics and other smallwares (cotton, manmade fibers, silk, and wool)—manufacturing.	221, 222, 223 and 224
		222	Knit goods—manufacturing.	2220	Knit goods—manufacturing.	225
		223	Dyeing and finishing of textiles (except wool fabrics and knit goods).	2230	Dyeing and finishing of textiles (except wool fabrics and knit goods).	226
		224	Floor coverings (rugs and carpets)—manufacturing.	2240	Floor coverings (rugs and carpets)—manufacturing.	227
		225	Yarns and threads—manufacturing.	2250	Yarns and threads—manufacturing.	228
		229	Other textile goods manufacturing, NEC.	2291	Felt goods (except woven felt- and hats)—manufacturing.	2291
				2292	Lace goods—manufacturing.	2292
				2293	Padding and upholstery filling—manufacturing.	2293
				2294	Processing waste and recovering fibers and flock.	2294
				2295	Artificial leather and oil cloth manufacturing and other impregnating and coating fabrics (except rubberizing).	2295
				2296	Tire cord and fabric—manufacturing.	2296
				2297	Wool scouring, worsted combing, and towing to top.	2297
				2299	Other textile goods manufacturing, NEC.	2299

23	Apparel and other finished products made from fabrics, leather, and similar materials—manufacturing.			
231	Men's, youths', and boys' suits, coats, and overcoats—manufacturing.	2310	Men's, youths', and boys' suits, coats, and overcoats—manufacturing.	231
232	Men's, youths', and boys' furnishings, work clothing, and allied garments—manufacturing.	2320	Men's, youths', and boys' furnishings, work clothing, and allied garments—manufacturing.	232
233	Women's, misses', juniors', girls', children's, and infants' outerwear—manufacturing.	2330	Women's, misses', juniors', girls', children's, and infants' outerwear—manufacturing.	233 and 236
234	Women's, misses', children's, and infants' undergarments—manufacturing.	2340	Women's, misses', children's, and infants' undergarments—manufacturing.	234
235	Hats, caps, and millinery—manufacturing.	2350	Hats, caps, and millinery—manufacturing.	235
236	Leather and leather products—manufacturing.	2361	Leather tanning and finishing.	3111
		2362	Industrial leather belting and packing—manufacturing.	3121
		2363	Boot and shoe cut stock and findings—manufacturing.	3131
		2364	Footwear (except rubber)—manufacturing.	314
		2365	Leather gloves and mittens—manufacturing.	315
		2366	Luggage—manufacturing.	316
		2367	Handbags and other personal leather goods—manufacturing.	317
		2369	Other leather products manufacturing, NEC.	319
237	Fur goods—manufacturing.	2370	Fur goods—manufacturing.	237

MANUFACTURING—2 AND 3

**B. A STANDARD SYSTEM FOR IDENTIFYING AND CODING LAND USE ACTIVITIES—TWO-, THREE-, AND FOUR-DIGIT LEVELS—Continued**

<i>Code</i>	<i>Category</i>	<i>Code</i>	<i>Category</i>	<i>Code</i>	<i>Category</i>	<i>SIC Reference</i> <sup>1</sup>
23	Apparel and other finished products made from fabrics, leather, and similar materials—manufacturing—Continued	238	Miscellaneous apparel and accessories—manufacturing.	2381	Dress and work gloves (except knit and all leather)—manufacturing.	2381
				2382	Robes and dressing gowns—manufacturing.	2384
				2383	Raincoats and other waterproof outer garments—manufacturing.	2385
				2384	Leather and sheep lined clothing—manufacturing.	2386
				2385	Apparel belts—manufacturing.	2387
				2389	Other miscellaneous apparel and accessory manufacturing, NEC.	2389
				239	Other fabricated textile products manufacturing, NEC.	2391
		2392	Housefurnishings (except curtains and draperies)—manufacturing.			2392
		2393	Textile bags—manufacturing.			2393
		2394	Canvas products—manufacturing.			2394
		2395	Pleating, decorative and novelty stitching and tucking for the trade.			2395
		2396	Apparel findings and related products—manufacturing.			2396
		2399	Other fabricated textile products manufacturing, NEC.			2397 and 2399
		24	Lumber and wood products (except furniture)—manufacturing.	241	Logging camps and logging contractors.	2410
242	Sawmills and planing mills.					2421
				2422	Hardwood dimension and flooring—manufacturing.	2426

		2429	Special sawmill products manufacturing, NEC.	2429
	243	Millwork, veneer, plywood, and prefabricated structural wood products—manufacturing.	2431 Millwork. 2432 Veneer and plywood—manufacturing. 2433 Prefabricating wooden buildings and structural members—manufacturing.	2431 2432 2433
	244	Wooden containers—manufacturing.	2440 Wooden containers—manufacturing.	244
	249	Other lumber and wood products (except furniture) manufacturing, NEC.	2491 Wood preserving. 2499 Other lumber and wood products (except furniture) manufacturing, NEC.	2491 2499
25	Furniture and fixtures—manufacturing.	251	Household furniture—manufacturing.	251
		252	Office furniture—manufacturing.	252
		253	Public building and related furniture—manufacturing.	2531
		254	Partitions, shelving, lockers, and office and store fixtures—manufacturing.	254
		259	Other furniture and fixtures manufacturing, NEC.	2591 Venetian blinds and shades—manufacturing. 2599 Other furniture and fixtures manufacturing, NEC.
26	Paper and allied products—manufacturing.	261	Pulp—manufacturing.	261
		262	Paper (except building paper)—manufacturing.	262
		2610	Pulp—manufacturing.	2610
		2620	Paper (except building paper)—manufacturing.	2620



**B. A STANDARD SYSTEM FOR IDENTIFYING AND CODING LAND USE ACTIVITIES—TWO-, THREE-, AND FOUR-DIGIT LEVELS—Continued**

<i>Code</i>	<i>Category</i>	<i>Code</i>	<i>Category</i>	<i>Code</i>	<i>Category</i>	<i>SIC Reference</i> <sup>1</sup>
26	Paper and allied products— manufacturing—Con.	263	Paperboard—manufacturing.	2630	Paperboard—manufacturing.	263
		264	Converted paper and paperboard products (except containers and boxes)—manufacturing.	2641	Paper coating and glazing.	2641
				2642	Envelope—manufacturing.	2642
				2643	Bags (except textile bags)—manu- facturing.	2643
				2644	Wallpaper—manufacturing.	2644
				2645	Die cut paper and paperboard; and cardboard—manufacturing.	2645
				2646	Pressed and molded pulp goods— manufacturing.	2646
				2647	Sanitary paper products—manufac- turing.	2647
				2649	Other converted paper and paper- board products (except containers and boxes) manufacturing, NEC.	2649
		265	Paperboard containers and boxes— manufacturing.	2650	Paperboard containers and boxes— manufacturing.	265
		266	Building paper and building board—manufacturing.	2660	Building paper and building board— manufacturing.	266
27	Printing, publishing, and allied industries.	271	Newspapers: publishing, publish- ing and printing.	2710	Newspapers: publishing, publishing and printing.	271
		272	Periodicals: publishing, publishing and printing.	2720	Periodicals: publishing, publishing and printing.	272
		273	Books: publishing, publishing and printing.	2730	Books: publishing, publishing and printing.	273
		274	Commercial printing.	2740	Commercial printing.	275
		275	Manifold business forms—manu- facturing.	2750	Manifold business forms—manufac- turing.	276

	276	Greeting card—manufacturing.	2760	Greeting card—manufacturing.	277
	277	Bookbinding and related industries—manufacturing.	2771	Blankbooks, looseleaf binders, and devices—manufacturing.	2782
			2772	Bookbinding and miscellaneous related work—manufacturing.	2789
	278	Printing trade service industries.	2781	Typesetting.	2791
			2782	Photoengraving.	2793
			2788	Electrotyping and stereotyping.	2794
			2789	Other printing trade service industries, NEC.	2799
	279	Other printing and publishing, NEC.	2790	Other printing and publishing, NEC.	274
28		Chemicals and allied products—manufacturing.	281	Industrial inorganic and organic chemicals—manufacturing.	281
	282	Plastics materials and synthetic resins, synthetic rubber, synthetic and other manmade fibers (except glass)—manufacturing.	2820	Plastics materials and synthetic resins, synthetic rubber, synthetic and other manmade fibers (except glass)—manufacturing.	282
	283	Drug—manufacturing.	2831	Biological products—manufacturing.	2831
			2832	Medicinal chemicals and botanical products—manufacturing.	2833
			2833	Pharmaceutical preparations—manufacturing.	2834
	284	Soap, detergents, and cleaning preparations, perfumes, cosmetics, and other toilet preparations—manufacturing.	2841	Soap and detergents (except specialty cleaners)—manufacturing.	2841
			2842	Specialty cleaning, polishing, and sanitation preparations (except soap and detergents)—manufacturing.	2842
			2843	Surface active agents, finishing agents, sulfonated oils, and assistants—manufacturing.	2843
			2844	Perfumes, cosmetics, and other toilet preparations—manufacturing.	2844

**B. A STANDARD SYSTEM FOR IDENTIFYING AND CODING LAND USE ACTIVITIES—TWO-, THREE-, AND FOUR-DIGIT LEVELS—Continued**

<i>Code</i>	<i>Category</i>	<i>Code</i>	<i>Category</i>	<i>Code</i>	<i>Category</i>	<i>SIC Reference</i> <sup>1</sup>		
28	Chemicals and allied products—manufacturing—Continued	285	Paints, varnishes, lacquers, enamels, and allied products—manufacturing.	2850	Paints, varnishes, lacquers, enamels, and allied products—manufacturing.	285		
		286	Gum and wood chemicals—manufacturing.	2860	Gum and wood chemicals—manufacturing.	286		
		287	Agricultural chemicals—manufacturing.	2870	Agricultural chemicals—manufacturing.	287		
		289	Other chemicals and allied products—manufacturing, NEC.	2891	Glue and gelatin—manufacturing.	2891	Glue and gelatin—manufacturing.	2891
				2892	Explosives—manufacturing.	2892	Explosives—manufacturing.	2892
2893	Printing ink—manufacturing.			2893	Printing ink—manufacturing.	2893		
2894	Carbon black—manufacturing.			2894	Carbon black—manufacturing.	2895		
2899	Other chemicals and allied products manufacturing, NEC.	2899	Other chemicals and allied products manufacturing, NEC.	2899				
29	Petroleum refining and related industries.	291	Petroleum refining.	2910	Petroleum refining.	291		
		292	Paving and roofing materials—manufacturing.	2921	Paving mixtures and blocks—manufacturing.	2951		
				2922	Asphalt felts and coatings—manufacturing.	2952		
		299	Other petroleum refining and related industries, NEC.	2991	Lubricating oils and greases—manufacturing.	2992		
				2999	Other petroleum and coal products manufacturing, NEC.	2999		
31	Rubber and miscellaneous plastic products—manufacturing.	311	Tires and inner tubes—manufacturing.	3110	Tires and inner tubes—manufacturing.	301		

	312	Rubber footwear—manufacturing.	3120	Rubber footwear—manufacturing.	302
	313	Reclaiming rubber.	3130	Reclaiming rubber.	303
	314	Miscellaneous plastic products— manufacturing.	3140	Miscellaneous plastic products— manufacturing.	307
	319	Other fabricated rubber products manufacturing, NEC.	3190	Other fabricated rubber products manufacturing, NEC.	306
32		Stone, clay, and glass prod- ucts—manufacturing.	321	Flat glass—manufacturing.	3211 and incl. 3231
	322	Glass and glassware (pressed or blown)—manufacturing.	3221	Glass containers—manufacturing.	3221 and incl. 3231
			3229	Other glass and glassware (pressed or blown) manufacturing, NEC.	3229 and incl. 3231
	323	Cement (hydraulic)—manufactur- ing.	3230	Cement (hydraulic)—manufacturing.	324
	324	Structural clay products—manu- facturing.	3241	Brick and structural clay tile—manu- facturing.	3251
			3242	Ceramic wall and floor tile—manu- facturing.	3253
			3243	Clay refractories—manufacturing.	3255
			3249	Other structural clay products manu- facturing, NEC.	3259
	325	Pottery and related products— manufacturing.	3251	Vitreous china plumbing fixtures, china, earthenware fittings, and bathroom accessories—manufac- turing.	3261
			3252	Vitreous china table and kitchen articles—manufacturing.	3262
			3253	Fine earthenware (whiteware) table and kitchen articles—manufac- turing.	3263
			3254	Porcelain electrical supplies—manu- facturing.	3264
			3259	Other pottery and related products manufacturing, NEC.	3269

**B. A STANDARD SYSTEM FOR IDENTIFYING AND CODING LAND USE ACTIVITIES—TWO-, THREE-, AND FOUR-DIGIT LEVELS—Continued**

<i>Code</i>	<i>Category</i>	<i>Code</i>	<i>Category</i>	<i>Code</i>	<i>Category</i>	<i>SIC Reference</i>
32	Stone, clay, and glass products—manufacturing—Continued	326	Concrete, gypsum, and plaster products—manufacturing.	3261	Concrete brick and block—manufacturing.	3271
				3262	Concrete products (excluding brick and block)—manufacturing.	3272
				3263	Concrete (ready mixed)—manufacturing.	3273
				3264	Lime products—manufacturing.	3274
				3265	Gypsum products—manufacturing.	3275
33	Primary metal industries.	331	Blast furnaces, steel works, and the rolling and finishing of ferrous metals.	3270	Cut stone and stone products—manufacturing.	328
				3280	Abrasive, asbestos, and miscellaneous nonmetallic mineral products—manufacturing.	329
				3311	Blast furnaces (including coke ovens), steel works, and the rolling of ferrous metals.	3312
				3312	Electrometallurgical products—manufacturing.	3313
				3313	Steel wire drawing and steel nails and spikes—manufacturing.	3315
332	Iron and steel foundries.	3320	Iron and steel foundries.	3314	Cold rolled sheet, strip, and bars—manufacturing.	3316
				3315	Steel pipe and tubes—manufacturing.	3317
				3321	Primary smelting and refining of nonferrous metals.	3322
333	Primary smelting and refining of nonferrous metals.	3331	Primary smelting and refining of copper.	3331		

		3332	Primary smelting and refining of lead.	3332
		3333	Primary smelting and refining of zinc.	3333
		3334	Primary production of aluminum.	3334
		3339	Other primary smelting and refining of nonferrous metals, NEC.	3339
	334	3340	Secondary smelting and refining of nonferrous metals and alloys.	334
	335	3351	Rolling, drawing, and extruding of nonferrous metals.	3351
		3352	Rolling, drawing, and extruding of copper.	3352
		3353	Rolling, drawing, and extruding of aluminum.	3353
		3354	Rolling, drawing, and extruding of nonferrous metals (except copper and aluminum).	3356
		3354	Drawing and insulating of nonferrous wire.	3357
	336	3360	Nonferrous foundries.	336
	339	3390	Other primary metal industries, NEC.	339
34	Fabricated metal products—manufacturing.	341	Ordnance and accessories.	
		3411	Guns, howitzers, mortars, and related equipment—manufacturing.	191
		3412	Ammunition (except small arms) manufacturing and complete assembling of guided missiles and space vehicles.	192
		3413	Tanks and tank components—manufacturing.	193
		3414	Sighting and fire control equipment—manufacturing.	194
		3415	Small arms—manufacturing.	195
		3416	Small arms ammunition—manufacturing.	196
		3419	Other ordnance and accessories manufacturing, NEC.	199

MANUFACTURING—2 AND 3

**B. A STANDARD SYSTEM FOR IDENTIFYING AND CODING LAND USE ACTIVITIES—TWO-, THREE-, AND FOUR-DIGIT LEVELS—Continued**

<i>Code</i>	<i>Category</i>	<i>Code</i>	<i>Category</i>	<i>Code</i>	<i>Category</i>	<i>SIC Reference</i>
34	Fabricated metal products—manufacturing—Continued	342	Machinery (except electrical)—manufacturing.	3421	Engines and turbines—manufacturing.	351
				3422	Farm machinery and equipment—manufacturing.	352
				3423	Construction, mining, and materials handling machinery and equipment—manufacturing.	353
				3424	Metalworking machinery and equipment—manufacturing.	354
				3425	Special industry machinery (except metalworking machinery)—manufacturing.	355
				3426	General industrial machinery and equipment—manufacturing.	356
				3427	Office, computing, and accounting machines—manufacturing.	357
				3428	Service industry machines—manufacturing.	358
				3429	Other machinery manufacturing (except electrical), NEC.	359
		343	Electrical machinery, equipment, and supplies—manufacturing.	3431	Electrical transmission and distribution equipment—manufacturing.	361
				3432	Electrical industrial apparatus—manufacturing.	362
				3433	Household appliances—manufacturing.	363
				3434	Electric lighting and wiring equipment—manufacturing.	364

	3435	Radio and television receiving sets (except communication types)—manufacturing.	365
	3436	Communication equipment—manufacturing.	366
	3437	Electronic components and accessories—manufacturing.	367
	3439	Other electrical machinery, equipment, and supplies manufacturing, NEC.	369
344		Transportation equipment—manufacturing.	
	3441	Motor vehicles and motor vehicle equipment—manufacturing.	371
	3442	Aircraft and parts—manufacturing.	372
	3443	Ship and boat building and repairing.	373
	3444	Railroad equipment—manufacturing.	374
	3445	Motorcycles, bicycles, and parts—manufacturing.	375
	3449	Other transportation equipment manufacturing, NEC.	379
349		Other fabricated metal products manufacturing, NEC.	
	3491	Metal cans—manufacturing.	341
	3492	Cutlery, hand tools, and general hardware—manufacturing.	342
	3493	Heating apparatus (except electrical) and plumbing fixtures—manufacturing.	343
	3494	Fabricated structural metal products—manufacturing.	344
	3495	Screw machine products and bolts, nuts, screws, rivets, and washers—manufacturing.	345
	3496	Metal stamping—manufacturing.	346
	3497	Coating, engraving, and allied services.	347
	3498	Fabricated wire products (miscellaneous products)—manufacturing.	348
	3499	Other fabricated metal products manufacturing, NEC.	349

MANUFACTURING—2 AND 3



**B. A STANDARD SYSTEM FOR IDENTIFYING AND CODING LAND USE ACTIVITIES—TWO-, THREE-, AND FOUR-DIGIT LEVELS—Continued**

<i>Code</i>	<i>Category</i>	<i>Code</i>	<i>Category</i>	<i>Code</i>	<i>Category</i>	<i>SIC Reference</i> <sup>1</sup>
35	Professional, scientific, and controlling instruments; photographic and optical goods; watches and clocks—manufacturing.	351	Engineering, laboratory, and scientific and research instruments and associated equipment—manufacturing.	3510	Engineering, laboratory, and scientific and research instruments and associated equipment—manufacturing.	381
		352	Instruments for measuring, controlling, and indicating physical characteristics—manufacturing.	3521	Mechanical measuring and controlling instruments (except automatic temperature controls)—manufacturing.	3821
				3522	Automatic temperature controls—manufacturing.	3822
		353	Optical instruments and lenses—manufacturing.	3530	Optical instruments and lenses—manufacturing.	383
		354	Surgical, medical, and dental instruments and supplies—manufacturing.	3541	Surgical and medical instruments and apparatus—manufacturing.	3841
				3542	Orthopedic, prosthetic, and surgical appliances and supplies—manufacturing.	3842
				3543	Dental equipment and supplies—manufacturing.	3843
		355	Ophthalmic goods—manufacturing.	3550	Ophthalmic goods—manufacturing.	385
		356	Photographic equipment and supplies—manufacturing.	3560	Photographic equipment and supplies—manufacturing.	386

	357	Watches, clocks, clockwork operated devices, and parts—manufacturing.	3570	Watches, clocks, clockwork operated devices, and parts—manufacturing.	387		
39	Miscellaneous manufacturing, NEC.	391	Jewelry, silverware, and plated ware—manufacturing.	3911	Jewelry and precious metals—manufacturing.	3911	
				3912	Jewelers' findings and materials—manufacturing.	3912	
				3913	Lapidary work.	3913	
				3914	Silverware and plated ware—manufacturing.	3914	
			392	Musical instruments and parts—manufacturing.	3920	Musical instruments and parts—manufacturing.	393
			393	Toys, amusement, sporting, and athletic goods—manufacturing.	3930	Toys, amusement, sporting, and athletic goods—manufacturing.	394
			394	Pens, pencils, and other office and artists' materials—manufacturing.	3940	Pens, pencils, and other office and artists' materials—manufacturing.	395
			395	Costume jewelry, costume novelties, buttons, and miscellaneous notions (except precious metals)—manufacturing.	3950	Costume jewelry, costume novelties, buttons, and miscellaneous notions (except precious metals)—manufacturing.	396
			396	Tobacco—manufacturing.	3961	Cigarettes—manufacturing.	211
					3962	Cigars—manufacturing.	212
					3963	Tobacco (chewing and smoking) and snuff—manufacturing.	213
					3964	Tobacco stemming and redrying.	214
			397	Motion picture production.	3970	Motion picture production.	7811

**B. A STANDARD SYSTEM FOR IDENTIFYING AND CODING LAND USE ACTIVITIES—TWO-, THREE-, AND FOUR-DIGIT LEVELS—Continued**

<i>Code</i>	<i>Category</i>	<i>Code</i>	<i>Category</i>	<i>Code</i>	<i>Category</i>	<i>SIC Reference</i> <sup>1</sup>
39	Miscellaneous manufacturing, NEC—Continued	399	Other miscellaneous manufacturing, NEC.	3991	Brooms and brushes—manufacturing.	3981
				3992	Linoleum, asphalted-felt-base, and other hard surface floor cover manufacturing, NEC.	3982
				3993	Matches—manufacturing.	3983
				3994	Lamp shades—manufacturing.	3987
				3995	Morticians' goods—manufacturing.	3988
				3996	Fur dressing and dyeing	3992
				3997	Signs and advertising displays—manufacturing.	3993
				3998	Umbrellas, parasols, and canes—manufacturing.	3995
				3999	Other miscellaneous manufacturing, NEC.	3984 and 3999

**FOOTNOTES**

<sup>1</sup> The SIC codes are listed for purposes of reference. They are the codes in the SIC system that most nearly correspond to the 4-digit land use activity indicated. (See ch. III, sec. A3, "The Use of Standard Industrial Classification Nomenclature.") A dash indicates that there is no corresponding SIC code.

<i>Code</i>	<i>Category</i>	<i>Code</i>	<i>Category</i>	<i>Code</i>	<i>Category</i>	<i>SIC Reference</i> <sup>1</sup>		
41	Railroad, rapid rail transit, and street railway transportation.	411	Railroad transportation.	4111	Railroad right-of-way (excluding switching and marshaling yards).	—		
				4112	Railroad switching and marshaling yards.	—		
				4113	Railroad terminals (passenger).	—		
				4114	Railroad terminals (freight).	—		
				4115	Railroad terminals (passenger and freight).	—		
				4116	Railroad equipment and maintenance.	—		
				4119	Other railroad transportation, NEC.	—		
				412	Rapid rail transit and street railway transportation.	4121	Rapid rail transit and street railway right-of-way. <sup>2</sup>	—
						4122	Rapid rail transit and street railway passenger terminals. <sup>3</sup>	—
		4123	Rapid rail transit and street railway equipment maintenance.			—		
		4129	Other rapid rail transit and street railway transportation, NEC.			—		
		42	Motor vehicle transportation.			421	Bus transportation.	4211
				4212	Bus passenger terminals (local). <sup>4</sup>			—
				4213	Bus passenger terminals (intercity and local). <sup>4</sup>			—
4214	Bus garaging and equipment maintenance.			—				
4219	Other bus transportation, NEC.			—				
422	Motor freight transportation.			4221	Motor freight terminals.			—
				4222	Motor freight garaging and equipment maintenance.	—		
				4229	Other motor freight transportation, NEC.	—		

**B. A STANDARD SYSTEM FOR IDENTIFYING AND CODING LAND USE ACTIVITIES—TWO-, THREE-, AND FOUR-DIGIT LEVELS—Continued**

<i>Code</i>	<i>Category</i>	<i>Code</i>	<i>Category</i>	<i>Code</i>	<i>Category</i>	<i>SIC Reference</i> <sup>1</sup>
42	Motor vehicle transportation—Continued	429	Other motor vehicle transportation, NEC.	4291	Taxicab transportation.	4121
				4299	Other motor vehicle transportation, NEC.	—
43	Aircraft transportation.	431	Airports and flying fields.	4311	Airport and flying field landing/takeoff fields.	—
				4312	Airport and flying field terminals (passenger).	—
				4313	Airport and flying field terminals (freight).	—
				4314	Airport and flying field terminals (passenger and freight).	—
				4315	Aircraft storage and equipment maintenance.	—
				4319	Other airports and flying fields, NEC.	—
		439	Other aircraft transportation, NEC.	4391	Heliport landing/takeoff pads. <sup>5</sup>	—
				4399	Other aircraft transportation, NEC.	—
44	Marine craft transportation. <sup>6</sup>	441	Marine terminals. <sup>7</sup>	4411	Marine terminals (passenger). <sup>8</sup>	—
				4412	Marine terminals (freight).	—
				4413	Marine terminals (passenger and freight).	—
				4414	Marine terminals (commercial fishing).	—
				4419	Other marine terminals, NEC.	—
		449	Other marine craft transportation, NEC.	4490	Other marine craft transportation, NEC.	—
45	Highway and street right-of-way.	451	Freeways.	4510	Freeways. <sup>9</sup>	—
		452	Expressways.	4520	Expressways. <sup>10</sup>	—

	453	Parkways.	4530	Parkways. <sup>11</sup>	—
	454	Arterial streets.	4540	Arterial streets. <sup>12</sup>	—
	455	Collector/distributor streets.	4550	Collector/distributor streets. <sup>13</sup>	—
	456	Local access streets.	4560	Local access streets. <sup>14</sup>	—
	457	Alleys.	4570	Alleys. <sup>15</sup>	—
	459	Other highway and street right-of-way, NEC.	4590	Other highway and street right-of-way, NEC.	—
46	460	Automobile parking.	4600	Automobile parking. <sup>16</sup>	—
47	471	Telephone communication.	4711	Telephone exchange stations.	—
			4712	Telephone relay towers (microwave).	—
			4719	Other telephone communication, NEC.	—
	472	Telegraph communication.	4721	Telegraph message centers.	—
			4722	Telegraph transmitting and receiving stations (only).	—
			4729	Other telegraph communication, NEC.	—
	473	Radio communication.	4731	Radio broadcasting studios (only).	—
			4732	Radio transmitting stations and towers.	—
			4739	Other radio communication, NEC.	—
	474	Television communication.	4741	Television broadcasting studios (only).	—
			4742	Television transmitting stations and relay towers.	—
			4749	Other television communication, NEC.	—
	475	Radio and television communication (combined systems).	4751	Radio and television broadcasting studios, only (combined systems).	—
			4759	Other combined radio and television communication, NEC.	—
	479	Other communication, NEC.	4790	Other communication, NEC.	—

TRANSPORTATION, COMMUNICATION, AND UTILITIES—4

**B. A STANDARD SYSTEM FOR IDENTIFYING AND CODING LAND USE ACTIVITIES—TWO-, THREE-, AND FOUR-DIGIT LEVELS—Continued**

<i>Code</i>	<i>Category</i>	<i>Code</i>	<i>Category</i>	<i>Code</i>	<i>Category</i>	<i>SIC Reference</i> <sup>1</sup>		
48	Utilities.	481	Electric utility.	4811	Electric transmission right-of-way. <sup>12</sup>	—		
				4812	Electric generation plants.	—		
				4813	Electricity regulating substations.	—		
		482	Gas utility.	482	Gas utility.	4819	Other electric utility, NEC.	—
						4821	Gas pipeline right-of-way. <sup>12</sup>	—
						4822	Gas production plants.	—
						4823	Natural or manufactured gas storage and distribution points.	—
						4824	Gas pressure control stations.	—
						4829	Other gas utilities, NEC.	—
		483	Water utilities and irrigation.	483	Water utilities and irrigation.	4831	Water pipeline right-of-way. <sup>12</sup>	—
						4832	Water treatment plants (purification).	—
						4833	Water storage. <sup>13</sup>	—
						4834	Irrigation distribution channels.	—
						4835	Water pressure control stations.	—
						4839	Other water utilities and irrigation, NEC.	—
		484	Sewage disposal.	484	Sewage disposal.	4841	Sewage treatment plants.	—
						4842	Sewage sludge drying beds.	—
						4843	Sewage pressure control stations.	—
						4849	Other sewage disposal, NEC.	—
		485	Solid waste disposal.	485	Solid waste disposal.	4851	Refuse incineration.	—
						4852	Central garbage grinding stations.	—
4853	Compositing plants.					—		
4854	Sanitary land fills.					—		
4855	Refuse disposals.					—		

**B. A STANDARD SYSTEM FOR IDENTIFYING AND CODING LAND USE ACTIVITIES—TWO-, THREE-, AND FOUR-DIGIT LEVELS—Continued**

<i>Code</i>	<i>Category</i>	<i>Code</i>	<i>Category</i>	<i>Code</i>	<i>Category</i>	<i>SIC Reference</i> <sup>1</sup>		
48	Utilities.	481	Electric utility.	4811	Electric transmission right-of-way. <sup>17</sup>	—		
				4812	Electric generation plants.	—		
				4813	Electricity regulating substations.	—		
		482	Gas utility.	482	Gas utility.	4819	Other electric utility, NEC.	—
						4821	Gas pipeline right-of-way. <sup>17</sup>	—
						4822	Gas production plants.	—
						4823	Natural or manufactured gas storage and distribution points.	—
						4824	Gas pressure control stations.	—
						4829	Other gas utilities, NEC.	—
		483	Water utilities and irrigation.	483	Water utilities and irrigation.	4831	Water pipeline right-of-way. <sup>17</sup>	—
						4832	Water treatment plants (purification).	—
						4833	Water storage. <sup>18</sup>	—
						4834	Irrigation distribution channels.	—
						4835	Water pressure control stations.	—
						4839	Other water utilities and irrigation, NEC.	—
		484	Sewage disposal.	484	Sewage disposal.	4841	Sewage treatment plants.	—
						4842	Sewage sludge drying beds.	—
						4843	Sewage pressure control stations.	—
						4849	Other sewage disposal, NEC.	—
		485	Solid waste disposal.	485	Solid waste disposal.	4851	Refuse incineration.	—
						4852	Central garbage grinding stations.	—
4853	Compositing plants.					—		
4854	Sanitary land fills.					—		
4855	Refuse disposals.					—		



		4856	Industrial waste disposals.	—	
		4857	Active slag dumps and mineral waste disposals.	—	
		4859	Other solid waste disposal, NEC.	—	
	489	Other utilities, NEC.	4890	Other utilities, NEC.	
49	Other transportation, communication, and utilities, NEC.	491	Other pipeline right-of-way and pressure control stations, NEC.	4911	Petroleum pipeline right-of-way, <sup>17</sup>
				4912	Petroleum pressure control stations.
				4919	Other pipeline right-of-way and pressure control stations, NEC.
	492	Transportation services and arrangements.	4921	Freight forwarding services.	4041 and 4712
			4922	Packing and crating services.	4783
			4923	Travel arranging services.	472
			4924	Transportation ticket services, <sup>19</sup>	—
			4929	Other transportation services and arrangements, NEC.	—
	499	Other transportation, communication, and utilities, NEC.	4990	Other transportation, communication, and utilities, NEC.	—

**FOOTNOTES**

<sup>1</sup> The SIC codes are listed for purposes of reference. They are the codes in the SIC system that most nearly correspond to the 4-digit land use activity indicated. (See ch. III, sec. A3, "The Use of Standard Industrial Classification Nomenclature.") A dash indicates that there is no corresponding SIC code.

<sup>2</sup> Code 4121—"Rapid rail transit and street railway right-of-way" includes only that land which is not within public right-of-way (e.g., within a public street right-of-way). Railroad right-of-way used by rapid rail transit is considered to be railroad right-of-way and is coded 4111.

<sup>3</sup> Code 4122—"Rapid rail transit and street railway passenger terminals" identifies only those terminals that are not located within public right-of-way (e.g., within a public street right-of-way).

<sup>4</sup> Codes 4211, 4212, 4213—"Bus passenger terminals" identifies only those terminals that are not located on the public right-of-way (e.g., within a public street right-of-way).

<sup>5</sup> Code 4391—"Helicopter landing/takeoff pads" are identified only when they are separate activities and not a part of code 431, "Airports and flying fields."

<sup>6</sup> Code 44—"Marine craft transportation." The maintenance and repair of marine craft should be coded 3443, "Ship and boat building and repairing."

<sup>7</sup> Code 441—"Marine terminals" include all docking facilities (e.g., wharves, piers, and docks) and associated areas that are used by commercial passenger, freight, and fishing craft. Docking facilities that primarily serve recreational type of marine craft are identified under code 744, "Marinas."

<sup>8</sup> Code 4411—"Marine terminals (passenger)" include ferry terminals.

<sup>9</sup> Code 4510—"Freeways" are divided highways for through traffic with full control of access and no cross traffic at grade.

<sup>10</sup> Code 4520—"Expressways" are divided highways for through traffic with full or partial control of access with grade separations at major crossroads.

Footnotes continued on following page.

**B. A STANDARD SYSTEM FOR IDENTIFYING AND CODING LAND USE ACTIVITIES—TWO-, THREE-, AND FOUR-DIGIT LEVELS—Continued**

<sup>11</sup> Code 4530—"Parkways" are highways for noncommercial traffic, with full or partial control of access. They are located within a park or within a ribbon of parklike development.

<sup>12</sup> Code 4540—"Arterial streets" are those streets which serve movements of traffic and are not freeways, expressways, and parkways. Generally there is no control of access.

<sup>13</sup> Code 4550—"Collector/distributor streets" are those streets that collect traffic from the local streets and channel it into the arterial system. These streets also provide necessary cross-connections between arterials. The collector/distributor street does not handle long through trips, and it is not continuous for any great length.

<sup>14</sup> Code 4560—"Local access streets" are those used primarily for access to residences, businesses, or other abutting activities.

<sup>15</sup> Code 4570—"Alleys" are minor narrow streets usually without sidewalks and on which building adjoin from the rear.

<sup>16</sup> Code 4600—"Automobile parking" includes nonresidential off-street parking that is 5,000 square feet or greater (or approximately

17 parking spaces), and that serves no other single type of activity. This code includes parking on open lots, parking within parking structures, parking within structures that also house other activities (e.g., parking area in an office building), and the parking area at shopping centers. Parking areas of less than 5,000 square feet are not identified as a separate activity.

<sup>17</sup> Codes 4811, 4821, 4831, 4911—These codes identify those areas where the surface is devoted exclusively to the right-of-way of the respective activities and is used for no other purposes.

<sup>18</sup> Code 4833—"Water storage" includes impounded surface water areas or water tanks used for storage. Lakes or other natural water formations are identified under code 93, "Water areas."

<sup>19</sup> Code 4924—"Transportation ticket services" include the ticket offices of any of the transportation systems. The ticket offices are identified only when they are a separate and distinct activity, not located within one of the transportation terminals.

Code	Category	Code	Category	Code	Category	SIC Reference <sup>1</sup>
51	Wholesale trade. <sup>2</sup>	511	Motor vehicles and automotive equipment—wholesale.	5111	Automobiles and other motor vehicles—wholesale.	5012
				5112	Automotive equipment—wholesale.	5013
				5113	Tires and tubes—wholesale.	5014
		512	Drugs, chemicals, and allied products—wholesale.	5121	Drugs, drug proprietaries and druggists' sundries—wholesale.	5022
				5122	Paints and varnishes—wholesale.	5028
				5129	Other drugs, chemicals, and allied products, wholesale, NEC.	5029
		513	Dry goods and apparel—wholesale.	5131	Dry goods, piece goods, and notions—wholesale.	5032

	5132	Apparel and accessories, hosiery, and lingerie—wholesale.	5035
	5133	Footwear—wholesale.	5039
514		Groceries and related products—wholesale.	
	5141	Groceries (general line)—wholesale.	5042
	5142	Dairy products—wholesale.	5043
	5143	Poultry and poultry products—wholesale.	5044
	5144	Confectionery—wholesale.	5045
	5145	Fish and seafoods—wholesale.	5046
	5146	Meat and meat products—wholesale.	5047
	5147	Fruits and vegetables (fresh)—wholesale.	5048
	5149	Other groceries and related products wholesale, NEC.	5049
515		Farm products (raw materials)—wholesale.	
	5151	Cotton—wholesale.	Incl. 5051
	5152	Grain—wholesale.	Incl. 5051
	5153	Hides, skins, and raw furs—wholesale.	Incl. 5051
	5154	Leaf tobacco—wholesale.	Incl. 5051
	5155	Wool and mohair—wholesale.	Incl. 5051
	5156	Livestock—wholesale.	Incl. 5051
	5157	Horses and mules—wholesale.	Incl. 5051
	5159	Other farm products wholesale, NEC.	Incl. 5051
516		Electrical goods—wholesale.	
	5161	Electrical apparatus and equipment, wiring supplies, and construction materials—wholesale.	5063
	5162	Electrical appliances, television, and radio sets—wholesale.	5064
	5163	Electronic parts and equipment—wholesale.	5065
517		Hardware, plumbing, heating equipment, and supplies—wholesale.	
	5171	Hardware—wholesale.	5072
	5172	Plumbing and heating equipment and supplies—wholesale.	5074
	5173	Air conditioning, refrigerated equipment, and supplies—wholesale.	5077

**B. A STANDARD SYSTEM FOR IDENTIFYING AND CODING LAND USE ACTIVITIES—TWO-, THREE-, AND FOUR-DIGIT LEVELS—Continued**

<i>Code</i>	<i>Category</i>	<i>Code</i>	<i>Category</i>	<i>Code</i>	<i>Category</i>	<i>SIC Reference</i> <sup>1</sup>
51	Wholesale trade <sup>2</sup> — Continued	518	Machinery, equipment, and supplies—wholesale.	5181	Commercial and industrial machin- ery, equipment, and supplies— wholesale.	5082
				5182	Farm machinery and equipment— wholesale.	5083
				5183	Professional equipment and sup- plies—wholesale.	5086
				5184	Equipment and supplies for service establishments—wholesale.	5087
				5185	Transportation equipment and sup- plies (except motor vehicles)— wholesale.	5088
				5189	Other machinery, equipment, and supplies wholesale, NEC.	5089
		519	Other wholesale trade, NEC.	5191	Metals and minerals (except petro- leum products and scrap)—whole- sale.	5091
				5192	Petroleum bulk stations and termi- nals—wholesale.	5092
				5193	Scrap and waste materials—whole- sale.	5093
				5194	Tobacco and tobacco products— wholesale.	5094
				5195	Beer, wine, and distilled alcoholic beverages—wholesale.	5095
				5196	Paper and paper products—whole- sale.	5096
				5197	Furniture and homefurnishings— wholesale.	5097

			5198 Lumber and construction materials—wholesale.	5098
			5199 Other wholesale trade, NEC.	5099
52	Retail trade—building materials, hardware, and farm equipment.	521	Lumber and other building materials—retail.	5211 Lumber yards—retail. 5212 Building materials—retail.
		522	Heating and plumbing equipment—retail.	5220 Heating and plumbing equipment—retail.
		523	Paint, glass, and wallpaper—retail.	5230 Paint, glass, and wallpaper—retail.
		524	Electrical supplies—retail.	5240 Electrical supplies—retail.
		525	Hardware and farm equipment—retail.	5251 Hardware—retail. 5252 Farm equipment—retail.
53	Retail trade—general merchandise.	531	Department stores—retail.	5310 Department stores—retail.
		532	Mail order houses—retail.	5320 Mail order houses—retail.
		533	Limited price variety stores—retail.	5330 Limited price variety stores—retail.
		534	Merchandise vending machine operators—retail.	5340 Merchandise vending machine operators—retail.
		535	Direct selling organizations—retail.	5350 Direct selling organizations—retail.
		539	Other retail trade—general merchandise, NEC.	5391 Dry goods and general merchandise—retail. 5392 General stores—retail.
54	Retail trade—food.	541	Groceries (with or without meat)—retail.	5410 Groceries (with or without meat)—retail.
		542	Meats and fish—retail.	5421 Meats—retail. 5422 Fish and seafoods—retail.

**B. A STANDARD SYSTEM FOR IDENTIFYING AND CODING LAND USE ACTIVITIES—TWO-, THREE-, AND FOUR-DIGIT LEVELS—Continued**

<i>Code</i>	<i>Category</i>	<i>Code</i>	<i>Category</i>	<i>Code</i>	<i>Category</i>	<i>SIC Reference</i> <sup>1</sup>		
54	Retail trade—food— Continued	543	Fruits and vegetables—retail.	5430	Fruits and vegetables—retail.	543		
		544	Candy, nut, and confectionery— retail.	5440	Candy, nut, and confectionery— retail.	544		
		545	Dairy products—retail.	5450	Dairy products—retail.	545		
		546	Bakeries—retail.	5461	Bakeries (manufacturing)—retail. <sup>3</sup>	5462	Bakeries (nonmanufacturing)—re- tail. <sup>4</sup>	5462 5463
				549	Other retail trade—food, NEC.	5491	Egg and poultry—retail.	5491
				5499	Other retail trade—food, NEC.	5499	Other retail trade—food, NEC.	5499
55	Retail trade—automotive, marine craft, aircraft, and accessories.	551	Motor vehicles—retail.	5511	Motor vehicles (new and used cars)— retail.	551		
				5512	Motor vehicles (used cars only)— retail.	552		
		552	Tires, batteries, and acces- sories—retail.	5520	Tires, batteries, and accessories— retail.	553		
		553	Gasoline service stations.	5530	Gasoline service stations.	554		
		559	Other retail trade—automotive, marine craft, aircraft, and accessories, NEC.	5591	Marine craft and accessories—retail.	5591	Marine craft and accessories—retail.	Incl. 5599
5592	Aircraft and accessories—retail.			5592	Aircraft and accessories—retail.	Incl. 5599		
5599	Other retail trade—automotive, marine craft, aircraft, and acces- sories, NEC.			5599	Other retail trade—automotive, marine craft, aircraft, and acces- sories, NEC.	Incl. 5599		

56	Retail trade—apparel and accessories.	361	Men's and boys' clothing and furnishings—retail.	3610	Men's and boys' clothing and furnishings—retail.	561
		362	Women's ready-to-wear—retail.	3620	Women's ready-to-wear—retail.	562
		363	Women's accessories and specialties—retail.	3630	Women's accessories and specialties—retail.	563
		364	Children's and infants' wear—retail.	3640	Children's and infants' wear—retail.	564
		365	Family clothing—retail.	3650	Family clothing—retail.	565
		366	Shoes—retail.	3660	Shoes—retail.	566
		367	Custom tailoring.	3670	Custom tailoring.	567
		368	Furriers and fur apparel—retail.	3680	Furriers and fur apparel—retail.	568
		369	Other retail trade—apparel and accessories, NEC.	3690	Other retail trade—apparel and accessories, NEC.	569
57	Retail trade—furniture, homefurnishings, and equipment.	571	Furniture, homefurnishings, and equipment—retail.	5711	Furniture—retail.	5712
				5712	Floor coverings—retail.	5713
				5713	Draperies, curtains, and upholstery—retail.	5714
				5714	China, glassware, and metalware—retail.	5715
				5719	Other furniture, homefurnishings, and equipment retail, NEC.	5719
				572	Household appliances—retail.	5720
		573	Radios, televisions, and music supplies—retail.	5731	Radios and televisions—retail.	5732
		5732	Music supplies—retail.	5733		
58	Retail trade—eating and drinking.	581	Eating places.	5810	Eating places. <sup>3</sup>	5812
		582	Drinking places (alcoholic beverages).	5820	Drinking places (alcoholic beverages).	5813

**B. A STANDARD SYSTEM FOR IDENTIFYING AND CODING LAND USE ACTIVITIES—TWO-, THREE-, AND FOUR-DIGIT LEVELS—Continued**

<i>Code</i>	<i>Category</i>	<i>Code</i>	<i>Category</i>	<i>Code</i>	<i>Category</i>	<i>SIC Reference</i> <sup>1</sup>
59	Other retail trade, NEC.	591	Drug and proprietary—retail.	5910	Drug and proprietary—retail.	591
		592	Liquor—retail.	5920	Liquor—retail.	592
		593	Antiques and secondhand merchandise—retail.	5931	Antiques—retail.	5932
				5932	Secondhand merchandise—retail.	5933
		594	Book and stationery—retail.	5941	Books—retail.	5942
				5942	Stationery—retail.	5943
		595	Sporting goods and bicycles—retail.	5951	Sporting goods—retail.	5952
				5952	Bicycles—retail.	5953
		596	Farm and garden supplies—retail.	5961	Hay, grains, and feeds—retail.	5962
				5969	Other farm and garden supplies retail, NEC.	5969
		597	Jewelry—retail.	5970	Jewelry—retail.	597
		598	Fuel and ice—retail.	5981	Fuel and ice dealers (except fuel oil and bottled gas dealers)—retail.	5982
				5982	Fuel oil—retail.	5983
				5983	Bottled gas—retail.	5984
		599	Other retail trade, NEC.	5991	Florists—retail.	5992
				5992	Cigars and cigarettes—retail.	5993
				5993	Newspapers and magazines—retail.	5994
				5994	Cameras and photographic supplies—retail.	5996
				5995	Gifts, novelties, and souvenirs—retail.	5997
				5996	Optical goods—retail.	5998
				5999	Other retail trade, NEC.	5999



**FOOTNOTES**

<sup>1</sup> The SIC codes are listed for purposes of reference. They are the codes in the SIC system that most nearly correspond to the 4-digit land use activity indicated. (See ch. III, sec. A3, "The Use of Standard Industrial Classification Nomenclature.") A dash indicates that there is no corresponding SIC code.

<sup>2</sup> Code 51—"Wholesale trade." A code of "0" is used in the auxiliary position for those wholesalers who maintain a definite storage area on

the premises. For example, 5122-0 is a wholesaler of paints and varnishes who has a definite storage area set aside for his merchandise.

<sup>3</sup> Code 5461—"Bakeries (manufacturing)—retail" include only those bakeries that produce on the premises some or all of the products sold.

<sup>4</sup> Code 5462—"Bakeries (nonmanufacturing)—retail" include only those bakeries that do not produce on the premises the products that are sold.

<sup>5</sup> Code 5810—"Eating places" include both establishments serving only food as well as those serving both food and alcoholic beverages.

<i>Code</i>	<i>Category</i>	<i>Code</i>	<i>Category</i>	<i>Code</i>	<i>Category</i>	<i>SIC Reference</i> <sup>1</sup>			
61	Finance, insurance, and real estate services.	611	Banking and bank-related functions.	6111	Banking services.	601, 602, 603, and 604			
				6112	Bank-related functions		605		
				612	Credit services (other than banks).	6121	Savings and loan associations.	612	
						6122	Agricultural, business, and personal credit services (including credit unions).	613, 614, and 615	
				613	Security and commodity brokers, dealers, exchanges, and services.	6129	Other credit services (other than banks), NEC.	611 and 616	
						6131	Security brokers, dealers, and flotation services.	6211	
		6132	Commodity contracts brokers and dealers services.			6221			
		6133	Security and commodity exchanges.			623			
		614	Insurance carriers, agents, brokers, and services.	6134	Security and commodity allied services.	628			
				6141	Insurance carriers.	63			
				6142	Insurance agents, brokers, and services.	64			

**B. A STANDARD SYSTEM FOR IDENTIFYING AND CODING LAND USE ACTIVITIES—TWO-, THREE-, AND FOUR-DIGIT LEVELS—Continued**

<i>Code</i>	<i>Category</i>	<i>Code</i>	<i>Category</i>	<i>Code</i>	<i>Category</i>	<i>SIC Reference</i> <sup>1</sup>
61	Finance, insurance, and real estate services— Continued	615	Real estate and related services.	6151	Real estate operators (except developers) and lessors.	651
				6152	Real estate agents, brokers, and management services.	653
				6153	Title abstracting services.	654
				6154	Real estate subdividing and developing services.	655
				6155	Real estate operative builders.	656
				6156	Combinations of real estate, insurance, loan, and law services.	661
				6159	Other real estate and related services, NEC.	—
				616	Holding and investment services.	67
		619	Other finance, insurance, and real estate services, NEC.	—		
		62	Personal services.	621	Laundering, dry cleaning, and dyeing services.	6211
6212	Linen supply and industrial laundry services.					7213
6213	Diaper services.					7214
6214	Laundering and dry cleaning (self-service).					7215
6215	Rug cleaning and repair services.					7217
622	Photographic services (including commercial).					722

	623	Beauty and barber services.	6231	Beauty services.	723	
			6232	Barber services.	724	
	624	Funeral and crematory services; cemeteries.	6241	Funeral and crematory services.	726	
			6242	Cemeteries.	—	
	625	Apparel repair, alteration and cleaning pickup services; shoe repair services.	6251	Pressing, alteration, and garment repair; laundry and dry cleaning pickup services (only).	7271	
			6252	Fur repair and storage services.	7272	
			6253	Shoe repair, shoe shining, and hat cleaning services.	725	
	629	Other personal services, NEC.	6290	Other personal services, NEC.	729	
63	Business services.	631	Advertising services.	6311	Advertising services (general).	7311
				6312	Outdoor advertising services.	7312
				6319	Other advertising services, NEC.	7319
	632	Consumer and mercantile credit reporting services; adjustment and collection services.	6320	Consumer and mercantile credit reporting services; adjustment and collection services.	7321	
	633	Duplicating mailing and stenographic services.	6331	Direct mail advertising services.	7331	
			6332	Blueprinting and photocopying service.	7332	
			6339	Stenographic services and other duplicating and mailing services, NEC.	7339	
	634	Dwelling and other building services.	6341	Window cleaning services.	7341	
			6342	Disinfecting and exterminating services.	7342	
			6349	Other dwelling and building services, NEC.	7349	
	635	News syndicate services.	6350	News syndicate services.	735	
	636	Employment services.	6360	Employment services.	736	

**B. A STANDARD SYSTEM FOR IDENTIFYING AND CODING LAND USE ACTIVITIES—TWO-, THREE-, AND FOUR-DIGIT LEVELS—Continued**

<i>Code</i>	<i>Category</i>	<i>Code</i>	<i>Category</i>	<i>Code</i>	<i>Category</i>	<i>SIC Reference</i> <sup>1</sup>
63 Business services— Continued		637	Warehousing and storage services. <sup>2</sup>	6371	Farm products warehousing and storage (excluding stockyards).	4221
				6372	Stockyards.	4731
				6373	Refrigerated warehousing (except food lockers).	4222
				6374	Food lockers (with or without food preparation facilities).	4223
				6375	Household goods warehousing and storage.	4224
				6376	General warehousing and storage.	4225
				6379	Other warehousing and storage, NEC.	4226
		639	Other business services, NEC.	6391	Research, development, and testing services.	7391
				6392	Business and management consulting services.	7392
				6898	Detective and protective services.	7393
				6894	Equipment rental and leasing services.	7894
				6895	Photofinishing services.	7395
				6896	Trading stamp services.	7396
				6897	Automobile and truck rental services.	7511
				6398	Motion picture distribution and services.	7812 and 782
				6399	Other business services, NEC.	7399
				64	Repair services.	641
6412	Automobile wash services.	Incl. 7541				
6419	Other automobile services (except repair and wash), NEC.	Incl. 7541				

	649	Other repair services, NEC.	6491	Electrical repair services (except radio and television).	Incl. 7621	
			6492	Radio and television repair services.	7622	
			6493	Watch, clock, and jewelry repair services.	763	
			6494	Reupholstery and furniture repair services.	764	
			6495	Armature rewinding services.	7694	
			6499	Other repair services, NEC.	7699	
65	Professional services.	651	Medical and other health services.	6511	Physicians' services.	801, 803, and 804
				6512	Dental services.	802
				6513	Hospital services.	806
				6514	Medical laboratory services.	8071
				6515	Dental laboratory services.	8072
				6516	Sanitariums, convalescent, and rest home services.	8092
				6517	Medical clinics—out-patient services.	—
				6519	Other medical and health services, NEC.	8099
		652	Legal services.	6520	Legal services.	811
		659	Other professional services, NEC.	6591	Engineering and architectural services.	891
				6592	Educational and scientific research services.	892
				6593	Accounting, auditing, and book-keeping services.	893
				6594	Urban planning services.	Incl. 899
				6599	Other professional services, NEC.	Incl. 899
66	Contract construction services.	661	General contract construction services.	6611	Building construction—general contractor services.	151
				6619	Other general construction contractor services, NEC.	16

5 B. A STANDARD SYSTEM FOR IDENTIFYING AND CODING LAND USE ACTIVITIES—TWO-, THREE-, AND FOUR-DIGIT LEVELS—Continued

<i>Code</i>	<i>Category</i>	<i>Code</i>	<i>Category</i>	<i>Code</i>	<i>Category</i>	<i>SIC Reference</i> <sup>1</sup>		
66	Contract construction services—Continued	662	Special construction trade services.	6621	Plumbing, heating, and air conditioning services.	171		
				6622	Painting, paper hanging, and decorating services.	172		
				6623	Electrical services.	173		
				6624	Masonry, stonework, tile setting, and plastering services.	174		
				6625	Carpentering and wood flooring.	175		
				6626	Roofing and sheet metal services.	176		
				6627	Concrete services.	177		
				6628	Water well drilling services.	178		
				6629	Other special construction trade services, NEC.	179		
				67	Governmental services.	671	Executive, legislative, and judicial functions.	6710
672	Protective functions and their related activities.	6721	Police protection and related activities.					Incl. 919, 929, and 939
		6722	Fire protection and related activities.					Incl. 919, 929, and 939
673	Postal services.	6723	Civil defense and related activities.					Incl. 919, 929, and 939
		6729	Other protective functions and their related activities, NEC.					Incl. 919, 929, and 939
6730	Postal services.	Incl. 919						
674	Correctional institutions.	6741	Prisons.					Incl. 919, 929, and 939

		6749	Other correctional institutions, NEC.	Incl. 919, 929, and 939
675	Military bases and reservations. <sup>4</sup>	6751	Military training bases.	Incl. 919 and 929
		6752	Military defense installations.	Incl. 919 and 929
		6753	Military storage depots and trans- portation centers.	Incl. 919 and 929
		6754	Military maintenance centers.	Incl. 919 and 929
		6755	Military administration or command centers.	Incl. 919 and 929
		6756	Military communication centers.	Incl. 919 and 929
		6759	Other military bases and reserva- tions, NEC.	Incl. 919 and 929
68	Educational services.	681	Nursery, primary, and secondary education.	6811 Nursery schools. Incl. 821 6812 Primary (elementary) schools. <sup>5</sup> Incl. 821 6813 Secondary schools. <sup>6</sup> Incl. 821
		682	University, college, junior college, and professional school edu- cation.	6821 Universities and colleges. Incl. 8221 6822 Junior colleges. Incl. 8222 6823 Professional schools. Incl. 8221
		683	Special training and schooling.	6831 Vocational or trade schools. 8242 6832 Business and stenographic schools. Incl. 8299 6833 Barber and beauty schools. Incl. 723 and 724 6834 Art and music schools. Incl. 8299 6835 Dancing schools. Incl. 7911 6836 Driving schools. Incl. 8299 6837 Correspondence schools. 8241 6839 Other special training and schooling, Incl. 8299 NEC.

● B. A STANDARD SYSTEM FOR IDENTIFYING AND CODING LAND USE ACTIVITIES—TWO-, THREE-, AND FOUR-DIGIT LEVELS—Continued

<i>Code</i>	<i>Category</i>	<i>Code</i>	<i>Category</i>	<i>Code</i>	<i>Category</i>	<i>SIC Reference</i> <sup>1</sup>
69	Miscellaneous services.	691	Religious activities. <sup>7</sup>	6911	Churches, synagogues, and temples.	Incl. 866
				6919	Other religious activities, NEC.	Incl. 866
		692	Welfare and charitable services.	6920	Welfare and charitable services.	867
		699	Other miscellaneous services, NEC.	6991	Business associations.	861
				6992	Professional membership organizations.	862
				6993	Labor unions and similar labor organizations.	863
				6994	Civic, social, and fraternal associations.	864
				6999	Other miscellaneous services, NEC.	—

FOOTNOTES

<sup>1</sup> The SIC codes are listed for purposes of reference. They are the codes in the SIC system that most nearly correspond to the 4-digit land use activity indicated. (See ch. III, sec. A3, "The Use of Standard Industrial Classification Nomenclature.") A dash indicates that there is no corresponding SIC code.

<sup>2</sup> Code 637—"Warehousing and storage services" include only those facilities that are used by or are open to the public. When warehousing and storage is functionally and organizationally linked to another activity (e.g., a general contractor or an apparel manufacturer), the facilities are identified and coded the same as the parent activity and with a code of 4 (warehousing and storage) in the auxiliary position. For example, 2310-4 is a warehouse and storage area of a manufacturer of men's, youths', and boys' suits, coats, and overcoats.

<sup>3</sup> Code 6710—"Executive, legislative, and judicial functions" include only the central and administrative office activities of the agencies or special authorities involved in government functions, including the

legislature and courts. All operational activities (e.g., shipbuilding, schools, or hospitals) should be identified separately under the respective activity codes.

<sup>4</sup> Code 675—"Military bases and reservations" include the installations used by both the active military as well as the Reserves and the National Guard.

<sup>5</sup> Code 6812—"Primary (elementary) schools" may or may not include a kindergarten, but they do include grades 1 through 6.

<sup>6</sup> Code 6813—"Secondary schools" are schools that include grades 7 through 12, popularly known as junior and senior high schools.

<sup>7</sup> Code 691—"Religious activities" include only those places operated for worship or for the promotion of religious activities. Activities maintained by the religious organizations (e.g., schools, hospitals, publishing houses, etc.) should be identified separately under the respective activity codes.



<i>Code</i>	<i>Category</i>	<i>Code</i>	<i>Category</i>	<i>Code</i>	<i>Category</i>	<i>SIC Reference</i> <sup>1</sup>		
71	Cultural activities and nature exhibitions.	711	Cultural activities.	7111	Libraries.	823		
				7112	Museums.	Incl. 841		
				7113	Art galleries. <sup>2</sup>	Incl. 841		
		712	Nature exhibitions.	7119	Other cultural activities, NEC.	7119	Other cultural activities, NEC.	—
						7121	Planetaria.	—
						7122	Aquariums.	Incl. 8421
						7123	Botanical gardens and arboretums.	Incl. 842
						7124	Zoos.	—
						7129	Other nature exhibitions, NEC.	—
		719	Other cultural activities and nature exhibitions, NEC.	7191	Other cultural activities and nature exhibitions, NEC.	7191	Historic and monument sites. <sup>3</sup>	—
						7199	Other cultural activities and nature exhibitions, NEC.	—
		72	Public assembly.	721	Entertainment assembly.	7211	Amphitheatres.	—
7212	Motion picture theaters.					Incl. 7831		
7213	Drive-in movies.					Incl. 7831		
7214	Legitimate theaters.					—		
7219	Other entertainment assembly, NEC.					—		
722	Sports assembly. <sup>4</sup>					7221	Stadiums. <sup>5</sup>	Incl. 7941
				7222	Arenas and field houses.	—		
				7223	Race tracks. <sup>6</sup>	Incl. 7948		
7229	Other sports assembly, NEC.			7229	Other sports assembly, NEC.	—		
				7231	Auditoriums.	—		
723	Public assembly, miscellaneous purposes.			7232	Exhibition halls.	—		
				7239	Other miscellaneous assembly, NEC.	—		
				7290	Other public assembly, NEC.	—		
729	Other public assembly, NEC.			7290	Other public assembly, NEC.	—		
				731	Fairgrounds and amusement parks.	7311	Fairgrounds.	Incl. 7949
		7312	Amusement parks.			Incl. 7949		

**B. A STANDARD SYSTEM FOR IDENTIFYING AND CODING LAND USE ACTIVITIES—TWO-, THREE-, AND FOUR-DIGIT LEVELS—Continued**

<i>Code</i>	<i>Category</i>	<i>Code</i>	<i>Category</i>	<i>Code</i>	<i>Category</i>	<i>SIC Reference</i> <sup>1</sup>
73	Amusements—Continued	739	Other amusements, NEC.	7391	Penny arcades.	Incl. 7949
				7392	Miniature golf.	Incl. 7949
				7393	Golf driving ranges.	Incl. 7949
				7394	Go-cart tracks.	Incl. 7949
				7399	Other amusements, NEC.	Incl. 7949
74	Recreational activities.	741	Sports activities.	7411	Golf courses (without country club).	7942
				7412	Golf courses (with country club).	7947
				7413	Tennis courts.	—
				7414	Ice skating.	Incl. 7945
				7415	Roller skating.	Incl. 7945
				7416	Riding stables.	—
				7417	Bowling.	Incl. 7931
				7418	Skiing and tobogganing.	—
				7419	Other sports activities, NEC.	—
		742	Playgrounds and athletic areas.	7421	Play lots or tot lots. <sup>7</sup>	—
				7422	Playgrounds. <sup>8</sup>	—
				7423	Playfields or athletic fields. <sup>9</sup>	—
				7424	Recreation centers (general). <sup>10</sup>	—
				7425	Gymnasiums and athletic clubs.	Incl. 7949
				7429	Other playground and athletic areas, NEC.	—
		743	Swimming areas.	7431	Swimming beaches. <sup>11</sup>	—
				7432	Swimming pools. <sup>12</sup>	7944
		744	Marinas. <sup>13</sup>	7441	Yachting clubs.	Incl. 7949
				7442	Boat rentals and boat access sites.	—
				7449	Other marinas, NEC.	—
		749	Other recreation, NEC.	7491	Camping and picnicing areas. <sup>14</sup>	—
				7499	Other recreation, NEC.	—

75	Resorts and group camps.	751	Resorts.	7511	General resorts. <sup>14</sup>	—
				7512	Dude ranches.	Incl. 7032
				7513	Health resorts.	Incl. 8092
				7514	Ski resorts.	—
				7515	Hunting and fishing clubs. <sup>15</sup>	Incl. 7032
				7519	Other resorts, NEC.	—
		752	Group or organized camps.	7520	Group or organized camps. <sup>17</sup>	Incl. 7032
76	Parks.	761	Parks—general recreation.	7610	Parks—general recreation. <sup>18</sup>	—
		762	Parks—leisure and ornamental.	7620	Parks—leisure and ornamental. <sup>19</sup>	—
		769	Other parks, NEC.	7690	Other parks, NEC.	—
79	Other cultural, entertainment, and recreational activities, NEC.	790	Other cultural, entertainment, and recreational activities, NEC.	7900	Other cultural, entertainment, and recreational activities, NEC.	—

#### FOOTNOTES

<sup>1</sup> The SIC codes are listed for purposes of reference. They are the codes in the SIC system that most nearly correspond to the 4-digit land use activity indicated. (See ch. III, sec. A3, "The Use of Standard Industrial Classification Nomenclature.") A dash indicates that there is no corresponding SIC code.

<sup>2</sup> Code 7113—"Art galleries" do not include those galleries that sell art objects commercially. Commercial sales are coded 5999, "Other retail trade, NEC."

<sup>3</sup> Code 7191—"Historic and monument sites" include those locations set aside for no other purpose than to commemorate an historical event, activity, or person.

<sup>4</sup> Code 722—"Sports assembly" includes only the public assembly areas used for nonparticipating sports.

<sup>5</sup> Code 7221—"Stadiums" include those used for individual sports, e.g., baseball or football, as well as those used for several sports activities.

<sup>6</sup> Code 7223—"Race tracks" include those used for individual racing activities, e.g., horse racing and automobile racing, as well as those used for several racing activities.

<sup>7</sup> Code 7421—"Play lots or tot lots" are small areas developed especially for preschool or elementary school aged children. They may

contain such facilities as sand boxes, slides, teeters, swings, climbing apparatus, etc. They are identified and coded only when found as a separate activity and not subsidiary to or serving another activity (e.g., apartment house or playground).

<sup>8</sup> Code 7422—"Playgrounds" are areas that have been developed for active play and recreation. They are identified and coded only when found as a separate activity and not subsidiary to or serving another activity (e.g., a school).

<sup>9</sup> Code 7423—"Playfields or athletic fields" contain a playground as well as a field(s) or court(s) for competitive sports (e.g., baseball, football, or tennis). Bleachers or grandstands may be provided. They are identified and coded only when found as a separate activity and not subsidiary to or serving another activity (e.g., a school).

<sup>10</sup> Code 7424—"Recreation centers (general)" include diversified recreation for a wide variety of activities for all ages and interests. The recreation centers may contain, but are not limited to a gymnasium, social or play rooms, game rooms, arts and craft shops, etc.

<sup>11</sup> Code 7431—"Swimming beaches" are beach areas that have been set aside specifically for the purpose of swimming. They are identified only when they are not a part of a larger activity (e.g., a park).

<sup>12</sup> Code 7432—"Swimming pools" are separately identified if they are

Footnotes continued on following page.

**B. A STANDARD SYSTEM FOR IDENTIFYING AND CODING LAND USE ACTIVITIES—TWO-, THREE-, AND FOUR-DIGIT LEVELS—Continued**

independent of other functions (e.g., code 72, "Public assembly" or code 11, "Household units"). They may be indoor or outdoor pools.

<sup>13</sup> Code 744—"Marinas" include marine terminals and associated areas that are primarily for recreational marine craft. The sale and repair of recreational marine craft is coded 5591, "Marine craft and accessories—retail" and code 3443, "Ship and boat building and repairing," respectively.

<sup>14</sup> Code 7491—"Camping and picnicing areas" are separately identified if they are not a part of a larger activity (e.g., a park).

<sup>15</sup> Code 7511—"General resorts" have rooms for 20 or more persons and have provision for at least 2 types of recreational activities, excluding lawn games, children's playgrounds, and swimming pools.

<sup>16</sup> Code 7515—"Hunting and fishing clubs" include areas on which artificially propagated game or fish are released for purposes of hunting or fishing. If there are other uses made of the property (e.g., agricultural use), these "other" uses should take priority in identifying the activity of the parcel.

<sup>17</sup> Code 7520—"Group or organized camps" include general camps for children, as well as Boy Scout and Girl Scout camps.

<sup>18</sup> Code 7610—"Parks—general recreation" may include, but are not limited to, picnic areas, bathing beaches, playfields, hiking trails, camping grounds, and other manmade recreation facilities.

<sup>19</sup> Code 7620—"Parks—leisure and ornamental" are largely for scenic or leisure purposes. They may contain beaches, children's play facilities, monuments, or statues.

<i>Code</i>	<i>Category</i>	<i>Code</i>	<i>Category</i>	<i>Code</i>	<i>Category</i>	<i>SIC Reference</i> <sup>1</sup>
81	Agriculture. <sup>2</sup>	811	Farms (predominant crop, fibers). <sup>3</sup>	8111	Farms (predominant crop, cotton).	—
				8119	Farms (other type fiber crops).	—
		812	Farms (predominant crop, cash grains). <sup>3</sup>	8120	Farms (predominant crop, cash grains).	—
		813	Farms (field crops other than fiber or cash grain crops). <sup>3</sup>	8130	Farms (field crops other than fiber or cash grain crops).	—
		814	Farms (predominant crop, fruits, tree nuts, or vegetables). <sup>3</sup>	8141	Farms (predominant crop, fruits).	—
				8142	Farms (predominant crop, tree nuts).	—
				8143	Farms (predominant crop, vegetables).	—
		815	Farms (predominantly dairy products). <sup>3</sup>	8150	Farms (predominantly dairy products).	—

	816 Farms and ranches (livestock other than dairy). <sup>1</sup>	8161 Farms and ranches (predominantly cattle).	—
		8162 Farms and ranches (predominantly hog).	—
		8163 Farms and ranches (predominantly sheep).	—
		8164 Farms and ranches (predominantly goat).	—
		8169 Farms and ranches (other livestock). NEC.	—
	817 Farms (predominantly poultry). <sup>2</sup>	8170 Farms (predominantly poultry).	—
	818 Farms (general—no predominance). <sup>3</sup>	8180 Farms (general—no predominance).	—
	819 Other agriculture and related activities, NEC.	8191 Range and grassland pastures (not farm or ranch). <sup>4</sup>	—
		8192 Horticultural specialties.	0192
		8193 Apiary farms.	Incl. 0193
		8194 Farms or ranches (predominantly horse raising).	Incl. 0193
		8199 Other agriculture and related activities, NEC.	—
82 Agricultural related activities.	821 Agricultural processing. <sup>5</sup>	8211 Cotton ginning and compressing.	0712
		8212 Grist milling services.	0713
		8213 Corn shelling, hay baling, and threshing services.	0714
		8214 Contract sorting, grading, and packaging services (fruits and vegetables).	0715
		8219 Other agricultural processing services, NEC.	0719
	822 Animal husbandry services.	8221 Veterinarian services.	Incl. 0722
		8222 Animal hospital services.	Incl. 0722
		8223 Poultry hatchery services.	0723
		8229 Other animal husbandry services, NEC.	0729

RESOURCE PRODUCTION AND EXTRACTION—8

**B. A STANDARD SYSTEM FOR IDENTIFYING AND CODING LAND USE ACTIVITIES—TWO-, THREE-, AND FOUR-DIGIT LEVELS—Continued**

<i>Code</i>	<i>Category</i>	<i>Code</i>	<i>Category</i>	<i>Code</i>	<i>Category</i>	<i>SIC Reference</i> <sup>1</sup>		
82	Agricultural related activities—Continued	829	Other agricultural related activities, NEC.	8291	Horticultural services.	0731		
				8299	Other agricultural related activities, NEC.	—		
83	Forestry activities and related services. <sup>8</sup>	831	Commercial forestry production. <sup>7</sup>	8311	Timber production—predominantly for pulp wood.	—		
				8312	Timber production—predominantly for saw logs.	—		
				8313	Timber production—predominantly for veneer logs.	—		
				8314	Timber production—mixed uses.	—		
				8315	Tree products production—predominantly gum extracting (except pine gum) and bark.	0842		
				8316	Tree products production—predominantly pine gum extraction.	0843		
				8317	Timber and tree products production—mixed uses.	—		
				8319	Other commercial forestry production, NEC.	—		
				832	Forestry services.	8321	Forest nurseries.	0822
						8329	Other forestry services, NEC.	0851
				839	Other forestry activities and related services, NEC.	8390	Other forestry activities and related services, NEC.	—
—	—							
84	Fishing activities and related services.	841	Fisheries and marine products. <sup>7</sup>	8411	Finfish fisheries.	0912		
				8412	Shellfish fisheries.	0913		
				8419	Other fisheries and marine products, NEC.	0914 and 0919		
				—	—	—		

	849	Other fishery activities and related services, NEC.	8490	Other fishery activities and related services, NEC.	—
85 Mining activities and related services. <sup>9</sup>	851	Metal ore mining.	8511	Iron ore-mining.	101
			8512	Copper ore-mining.	102
			8518	Lead and zinc ore-mining.	109
			8514	Gold and silver ore-mining.	104
			8515	Bauxite and other aluminum ore-mining.	105
			8516	Ferroalloy ore (except vanadium)—mining.	106
			8519	Other metal ore mining, NEC.	109
	852	Coal mining.	8521	Anthracite coal-mining.	111
			8522	Bituminous coal-mining.	1211
			8523	Lignite coal-mining.	1212
853	Crude petroleum and natural gas.	8530	Crude petroleum and natural gas.	131	
854 Mining and quarrying of non-metallic minerals (except fuels).	8541	Dimension stone.	8541	Dimension stone.	141
	8542	Crushed and broken stone (including riprap)—quarrying.	8542	Crushed and broken stone (including riprap)—quarrying.	142
	8543	Sand and gravel—quarrying.	8543	Sand and gravel—quarrying.	144
	8544	Clay, ceramic, and refractory minerals—mining.	8544	Clay, ceramic, and refractory minerals—mining.	145
	8545	Chemical and fertilizers (mineral)—mining.	8545	Chemical and fertilizers (mineral)—mining.	147
	8549	Other mining and quarrying of non-metallic minerals (except fuels), NEC.	8549	Other mining and quarrying of non-metallic minerals (except fuels), NEC.	148
	855	Mining services.	8551	Metal mining-services.	108
		8552	Coal mining-services.	1112 and 1213	
		8553	Crude petroleum and gas field-services.	138	
		8554	Nonmetallic mining (except fuel)—services.	148	
		8559	Other mining services, NEC.	—	
89 Other resource production and extraction, NEC.	890	Other resource production and extraction, NEC.	8900	Other resource production and extraction, NEC.	—

RESOURCE PRODUCTION AND EXTRACTION—8

## B. A STANDARD SYSTEM FOR IDENTIFYING AND CODING LAND USE ACTIVITIES—TWO-, THREE-, AND FOUR-DIGIT LEVELS—Continued

### FOOTNOTES

<sup>1</sup> The SIC codes are listed for purposes of reference. They are the codes in the SIC system that most nearly correspond to the 4-digit land use activity indicated. (See ch. III, sec. A3, "The Use of Standard Industrial Classification Nomenclature.") A dash indicates that there is no corresponding SIC code.

<sup>2</sup> Code 81—"Agriculture." A parcel of land is considered to be in agricultural use if 10 or more acres are under cultivation, in tree or bush crops, or are used for livestock or poultry purposes. The 10 acres may include the area of the residence, if there is one, and the immediate associated area surrounding the residence.

<sup>3</sup> A farm may consist of several ownership or rented parcels of land that are noncontiguous. However, each parcel should be linked together as one "farm management unit," and identified by only one 3- or 4-digit category, e.g., code 8120. "Farms (predominant crops, cash grains)."

Using the "Farm use" categories in app. 2 of this report, farm (i.e., the farm management units) are to be classified by the most predominant use made of the land (the farm use taking up the greatest percentage of farm area) excluding the areas used by farm residences and associated buildings, nonresident farm buildings, areas in feed crops, and grazed and nongrazed forested areas. Exceptions to this rule are:

a. If 50 percent or more of the value of the farm products sold in the previous year came from the sale of dairy products, or the sale of cows and calves, the farm is identified as "Farm (predominantly dairy products)," code 8150.

b. If 50 percent or more of the value of the farm products sold in the previous year came from the sale of livestock, wool, or mohair, the farm is identified as "Farms and ranches (livestock, other than dairy)," code 816.

c. If 50 percent or more of the value of the farm products sold in the previous year came from the sale of poultry and eggs, the farm is identified as "Farms (predominantly poultry)," code 8170.

d. If the percentage of dairy, livestock, and poultry products, each came to less than 50 percent of the value of the farm products sold in the previous years, and if there are 3 or more "Farm uses" (e.g., corn crop, cotton crop, etc.) within a farm, none of which takes up 25 percent of the total farm area (excluding those areas referred to above), the farm is identified as "Farms (general—no predominance)," code 8180.

<sup>4</sup> Code 819—"Range and grass land pastures (not farm or ranch)" include grasslands used for grazing purposes that are not a part of a

farm or ranch. These areas are usually part of the public domain in which grazing has been permitted.

<sup>5</sup> Code 821—"Agricultural processing" includes only preliminary processing of agricultural products. Any extensive processing, packing, canning, or manufacturing is coded 21. "Food and kindred products—manufacturing."

<sup>6</sup> Code 83—"Forestry activities and related services." The categories in this classification are based upon primary use of the land. It is recognized that other activities, e.g., recreation or the grazing of livestock may also be taking place within these forested areas. However, these types of activities are considered secondary in nature and not coded. Activities such as mining (code 85), permanent camping areas (code 7491), and logging camps (code 2410), located within the forested areas should be separately identified.

<sup>7</sup> Code 831—"Commercial forestry production" includes those forested areas not on the farms or ranches that are being managed or have been set aside to grow tree crops for "industrial wood" or to obtain tree products such as sap, bark, or seeds. "Industrial wood" includes commercial roundwood products, such as saw logs and pulpwood, but excludes fuel wood and fence posts. "Forest reserves," i.e., areas withdrawn from any commercial use of the trees, are coded 921. "Parks," e.g., national or State parks, are also a type of forest reserve, but because of their designation for recreational activity, they should be identified as "Parks" under code 76. Forested areas not on farms, ranches, or estates with no commercial use made of the trees are coded 922. "Nonreserve forests (undeveloped)."

<sup>8</sup> Code 841—"Fisheries and marine products" include those establishments primarily engaged in commercial fishing, the catching or taking of shellfish, or the gathering of seaweed, sponges, turtles, frogs, etc. These activities may include some preliminary processing, e.g., salting. However, any extensive processing, packing, canning, or manufacturing of these products should be coded under "Food and kindred products—manufacturing," code 21. These categories also include the docking facilities and their associated areas when these facilities are an integral part of a single fishery operation. When docking facilities serve several separate fishery establishments, they are coded 4414. "Marine terminals (predominantly fishing vessels)."

<sup>9</sup> Code 85—"Mining activities and related services" include those surface areas being used for mining or drilling purposes. The process may be tunnel excavation, strip mining, quarrying, or by drilling. These categories also include those areas where preliminary processing of raw materials (e.g., washing, crushing, screening, etc.) are taking place if these processes are an integral part of the mining operation.



<i>Code</i>	<i>Category</i>	<i>Code</i>	<i>Category</i>	<i>Code</i>	<i>Category</i>	<i>SIC Reference</i> <sup>1</sup>
91	Undeveloped and unused land area (excluding noncommercial forest development).	910	Undeveloped and unused land area (excluding noncommercial forest development).	9100	Undeveloped and unused land area (excluding noncommercial forest development). <sup>2</sup>	—
92	Noncommercial forest development.	921	Forest reserves. <sup>3</sup>	9211	Forest reserves (wilderness areas).	—
				9212	Forest reserves (wildlife refuges).	—
				9219	Other forest reserves, NEC.	—
		922	Nonreserve forests (undeveloped).	9220	Nonreserve forests (undeveloped). <sup>4</sup>	—
93	Water areas.	931	Rivers, streams, or creeks.	9310	Rivers, streams, or creeks.	—
		932	Lakes.	9320	Lakes. <sup>5</sup>	—
		933	Bays or lagoons.	9330	Bays or lagoons.	—
		934	Oceans and seas.	9340	Oceans and seas.	—
		939	Other water areas, NEC.	9390	Other water areas, NEC.	—
94	Vacant floor area.	940	Vacant floor area.	9400	Vacant floor area.	—
95	Under construction.	951	Under construction (residential).	9510	Under construction (residential). <sup>6</sup>	—
		952	Under construction (nonresidential).	9520	Under construction (nonresidential). <sup>7</sup>	—
99	Other undeveloped land and water areas, NEC.	990	Other undeveloped land and water areas, NEC.	9900	Other undeveloped land and water areas, NEC.	—

See footnotes on following page.

---

**B. A STANDARD SYSTEM FOR IDENTIFYING AND CODING LAND USE ACTIVITIES—TWO-, THREE-, AND FOUR-DIGIT LEVELS—Continued**

---

**FOOTNOTES**

<sup>1</sup> The SIC codes are listed for purposes of reference. They are the codes in the SIC system that most nearly correspond to the 4-digit land use activity indicated. (See ch. III, sec. 43, "The Use of Standard Industrial Classification Nomenclature.") A dash indicates that there is no corresponding SIC code.

<sup>2</sup> Code 9100—"Undeveloped and unused land area (excluding non-commercial forest development)" identifies those parcels of land that appear to be undeveloped or if previously developed, are presently vacant and unused. This category includes such areas as vacant lands that once were farms, as well as vacant parcels where structures have been demolished. Vacant nonresidential buildings are coded 9100, "Vacant floor area."

<sup>3</sup> Code 921—"Forest reserves" are forested areas withdrawn from commercial utilization, and which are reserved through statute or administrative regulation for specific conservation purposes. Forested areas designated as park sites may also be restricted from commercial forestry production, but because of their designation for recreational activity they should be identified and coded as "Parks" (code 76).

<sup>4</sup> Code 9220—"Nonreserve forests (undeveloped)" are major forested areas not on a farm, ranch, or large estate with no commercial use made of the trees. It is recognized that other activities such as recreation or the grazing of livestock may also be taking place within these forested areas. However, these types of activities are considered secondary in nature and not coded. Activities such as mining (code 85), permanent camping areas (code 7491), and logging camps (code 2410), located within these forested areas should be separately identified.

<sup>5</sup> Code 9320—"Lakes" include permanent lakes (natural or manmade) with a minimum size of 1 acre. Impounded surface water areas used for storage should be identified as "Water storage," code 4838.

<sup>6</sup> Code 9510—"Residential facilities under construction are considered to be completed when all exterior windows and doors are installed and the usable floors are in place. If construction has not reached this point, the parcel should be identified as "Under construction (residential)," code 9510.

<sup>7</sup> Code 9520—"Under construction (nonresidential)" is used only if there is no means of identifying the activity or activities that will occupy the structure when it is completed.

## C. ALPHABETIC INDEX OF LAND USE ACTIVITIES

### A

- 328 Abrasive, asbestos, and miscellaneous nonmetallic mineral products—  
manufacturing
- 3280 Abrasive, asbestos, and miscellaneous nonmetallic mineral products  
manufacturing
- 6593 Accounting, auditing, and bookkeeping services
- 4857 Active slag dumps and mineral waste disposals
- 631 Advertising services
- 6311 Advertising services (general)
- 6122 Agricultural, business, and personal credit services (including credit  
unions)
- 287 Agricultural chemicals—manufacturing
- 2870 Agricultural chemicals—manufacturing
- 821 Agricultural processing
- 82 Agricultural related activities
- 81 Agriculture
- 5173 Air conditioning, refrigerated equipment, and supplies—wholesale
- 5592 Aircraft and accessories—retail
- 3442 Aircraft and parts manufacturing
- 4315 Aircraft storage and equipment maintenance
- 43 Aircraft transportation
- 4311 Airport and flying field landing/takeoff fields
- 4313 Airport and flying field terminals (freight)
- 4312 Airport and flying field terminals (passenger)
- 4314 Airport and flying field terminals (passenger and freight)
- 431 Airports and flying fields
- 457 Alleys
- 4570 Alleys
- 3412 Ammunition (except small arms) manufacturing and complete assembling  
of guided missiles and space vehicles
- 7211 Amphitheaters
- 7312 Amusement parks
- 73 Amusements
- 2194 Animal and marine fats and oils (including grease and tallow)—manu-  
facturing
- 3222 Animal hospital services
- 322 Animal husbandry services
- 4521 Anthracite coal—mining
- 593 Antiques and secondhand merchandise—retail
- 5931 Antiques—retail
- 3193 Apiary farms
- 3132 Apparel and accessories, hosiery and lingerie—wholesale
- 23 Apparel and other finished products made from fabrics, leather, and simi-  
lar materials—manufacturing
- 3385 Apparel belts—manufacturing
- 3396 Apparel findings and related products—manufacturing

625 Apparel repair, alteration, and cleaning pickup services; shoe repair services  
 7122 Aquariums  
 7222 Arenas and field houses  
 6495 Armature rewinding services  
 6834 Art and music schools  
 454 Arterial streets  
 4540 Arterial streets  
 7113 Art galleries  
 2295 Artificial leather and oilcloth manufacturing and other impregnating and coating fabrics (except rubberizing)  
 2922 Asphalt felts and coatings - manufacturing  
 7231 Auditoriums  
 3522 Automatic temperature controls - manufacturing  
 6397 Automobile and truck rental services  
 46 Automobile parking  
 460 Automobile parking  
 4600 Automobile parking  
 641 Automobile repair and services  
 6411 Automobile repair services  
 5111 Automobiles and other motor vehicles - wholesale  
 6112 Automobile wash services  
 5112 Automotive equipment - wholesale

## **B**

2613 Bags (except textile bags) - manufacturing  
 5461 Bakeries (manufacturing) - retail  
 5462 Bakeries (nonmanufacturing) - retail  
 546 Bakeries - retail  
 215 Bakery products - manufacturing  
 2150 Bakery products - manufacturing  
 611 Banking and bank-related functions  
 6111 Banking services  
 6112 Bank-related functions  
 6833 Barber and beauty schools  
 6232 Barber services  
 8515 Bauxite and other aluminum ore - mining  
 933 Bays or lagoons  
 9330 Bays or lagoons  
 623 Beauty and barber services  
 6231 Beauty services  
 5195 Beer, wine, and distilled alcoholic beverages - wholesale  
 218 Beverage - manufacturing  
 5952 Bicycles - retail  
 2831 Biological products - manufacturing  
 3522 Bituminous coal - mining  
 2771 Blankbooks, looseleaf binders, and devices - manufacturing

- 3311 Blast furnaces (including coke ovens), steel works, and the rolling of ferrous metals
- 331 Blast furnaces, steel works, and the rolling and finishing of ferrous metals
- 2145 Blending and preparing flour
- 6332 Blueprinting and photocopying services
- 7442 Boat rentals and boat access sites
- 594 Book and stationery retail
- 2772 Bookbinding and miscellaneous related work manufacturing
- 277 Bookbinding and related industries manufacturing
- 273 Books publishing, publishing and printing
- 2730 Books publishing, publishing and printing
- 5944 Books—retail
- 2363 Boot and shoe cut stock and findings manufacturing
- 7123 Botanical gardens and arboreturns
- 5983 Bottled gas retail
- 2185 Bottling and canning soft drinks and carbonated waters
- 7447 Bowling
- 3244 Brick and structural clay tile manufacturing
- 221 Broad and narrow woven fabrics and other smallwares (cotton, manmade fibers, silk, and wool) manufacturing
- 2210 Broad and narrow woven fabrics and other smallwares (cotton, manmade fibers, silk, and wool) manufacturing
- 3991 Brooms and brushes manufacturing
- 6611 Building construction—general contractor services
- 5212 Building materials—retail
- 266 Building paper and building board manufacturing
- 2660 Building paper and building board manufacturing
- 4214 Bus garaging and equipment maintenance
- 6392 Business and management consulting services
- 6832 Business and stenographic schools
- 6991 Business associations
- 63 Business services
- 4211 Bus passenger terminals (intercity)
- 4213 Bus passenger terminals (intercity and local)
- 4212 Bus passenger terminals (local)
- 421 Bus transportation

## **C**

- 5994 Cameras and photographic supplies retail
- 7491 Camping and picnicking areas
- 2171 Candy and other confectionery products manufacturing
- 544 Candy, nut, and confectionery retail
- 5440 Candy, nut, and confectionery retail
- 2131 Canning and curing seafoods
- 213 Canning and preserving of fruits, vegetables, and seafoods
- 2133 Canning fruits, vegetables, preserves, jams, and jellies
- 2132 Canning specialty foods
- 2394 Canvas products—manufacturing

2894 Carbon black —manufacturing  
 6625 Carpentering and wood flooring  
 323 Cement (hydraulic) —manufacturing  
 3230 Cement (hydraulic)—manufacturing  
 6242 Cemeteries  
 4852 Central garbage grinding stations  
 3242 Ceramic wall and floor tile— manufacturing  
 2143 Cereal preparations  
 2122 Cheese (natural and processed)  
 8545 Chemical and fertilizers (mineral) — mining  
 28 Chemicals and allied products— manufacturing  
 2173 Chewing gum— manufacturing  
 564 Children's and infants' wear— retail  
 5640 Children's and infants' wear— retail  
 5714 China, glassware, and metalware— retail  
 2172 Chocolate and cocoa products —manufacturing  
 6911 Churches, synagogues, and temples  
 3961 Cigarettes—manufacturing  
 5992 Cigars and cigarettes—retail  
 3962 Cigars — manufacturing  
 6994 Civic, social, and fraternal associations  
 6723 Civil Defense and related activities  
 8544 Clay, ceramic, and refractory minerals — mining  
 3243 Clay refractories—manufacturing  
 852 Coal mining  
 8552 Coal mining—services  
 3497 Coating, engraving, and allied services  
 3314 Cold rolled sheet, strip, and bars — manufacturing  
 455 Collector/distributor streets  
 4550 Collector/distributor streets  
 1232 College dormitories  
 6156 Combinations of real estate, insurance, loan, and law services  
 5181 Commercial and industrial machinery, equipment, and supplies—whole-  
     sale  
 831 Commercial forestry production  
 274 Commercial printing  
 2740 Commercial printing  
 6132 Commodity contracts brokers and dealers services  
 47 Communication  
 3436 Communication equipment—manufacturing  
 4853 Compositing plants  
 3261 Concrete brick and block— manufacturing  
 326 Concrete, gypsum, and plaster products— manufacturing  
 3262 Concrete products (excluding brick and block) —manufacturing  
 3263 Concrete (ready mixed) — manufacturing  
 6627 Concrete services  
 2123 Condensed and evaporated milk—manufacturing  
 217 Confectionery and related products — manufacturing

5144 Confectionery--wholesale  
 3423 Construction, mining and materials handling machinery, and equipment—  
 manufacturing  
 632 Consumer and mercantile credit reporting services; adjustment and col-  
 lection services  
 6320 Consumer and mercantile credit reporting services; adjustment and col-  
 lection services  
 66 Contract construction services  
 8214 Contract sorting, grading, and packaging services (fruits and vegetables)  
 1251 Convents  
 264 Converted paper and paperboard products (except containers and  
 boxes) manufacturing  
 8512 Copper ore - mining  
 3213 Corn shelling, hay baling, and threshing services  
 674 Correctional institutions  
 6837 Correspondence schools  
 395 Costume jewelry, costume novelties, buttons, and miscellaneous notions  
 (except precious metals)—manufacturing  
 3950 Costume jewelry, costume novelties, buttons, and miscellaneous notions  
 (except precious metals) manufacturing  
 8211 Cotton ginning and compressing  
 2191 Cottonseed oil milling  
 5151 Cotton wholesale  
 2121 Creamery butter manufacturing  
 612 Credit services (other than banks)  
 8553 Crude petroleum and gas field—services  
 853 Crude petroleum and natural gas  
 8530 Crude petroleum and natural gas  
 3542 Crushed and broken stone (including riprap) quarrying  
 711 Cultural activities  
 71 Cultural activities and nature exhibitions  
 7 Cultural, entertainment, and recreational  
 2391 Curtains and draperies—manufacturing  
 567 Custom tailoring  
 5670 Custom tailoring  
 3492 Cutlery, hand tools, and general hardware -manufacturing  
 327 Cut stone and stone products-- manufacturing  
 3270 Cut stone and stone products—manufacturing

## **D**

212 Dairy products manufacturing  
 545 Dairy products retail  
 5450 Dairy products-- retail  
 5142 Dairy products—wholesale  
 3835 Dancing schools  
 3543 Dental equipment and supplies manufacturing  
 6515 Dental laboratory services  
 6512 Dental services

- 531 Department stores—retail
- 5310 Department stores—retail
- 6393 Detective and protective services
- 6213 Diaper services
- 2645 Die cut paper and paperboard and cardboard manufacturing
- 8541 Dimension stone—quarrying
- 6331 Direct mail advertising services
- 535 Direct selling organizations retail
- 5350 Direct selling organizations—retail
- 6342 Disinfecting and exterminating services
- 2184 Distilling, rectifying, and blending liquors
- 5713 Draperies, curtains, and upholstery—retail
- 3354 Drawing and insulating of nonferrous wire
- 2381 Dress and work gloves (except knit and all leather)—manufacturing
- ✓ 582 Drinking places (alcoholic beverages)
- 5820 Drinking places (alcoholic beverages)
- 7213 Drive-in movies
- 6836 Driving schools
- ✓ 591 Drug and proprietary—retail
- 5910 Drug and proprietary —retail
- 283 Drug—manufacturing
- 512 Drugs, chemicals, and allied products —wholesale
- 5121 Drugs, drug proprietaries, and druggists' sundries wholesale
- 513 Dry goods and apparel wholesale
- 5391 Dry goods and general merchandise retail
- 5131 Dry goods, piece goods, and notions wholesale
- 2134 Drying and dehydrating fruits and vegetables
- 7512 Dude ranches
- 633 Duplicating, mailing, and stenographic services
- 634 Dwelling and other building services
- 223 Dyeing and finishing of textiles (except wool fabrics and knit goods)
- 2230 Dyeing and finishing of textiles (except wool fabrics and knit goods)

## **E**

- ✓ 581 Eating places
- 5810 Eating places
- 6592 Educational and scientific research services
- 68 Educational services
- 5491 Egg and poultry —retail
- 5161 Electrical apparatus and equipment, wiring supplies, and construction materials wholesale
- 5162 Electrical appliances, television, and radio sets wholesale
- 516 Electrical goods —wholesale
- 3432 Electrical industrial apparatus manufacturing
- 343 Electrical machinery, equipment, and supplies—manufacturing
- 6491 Electrical repair services (except radio and television)
- 6623 Electrical services
- 524 Electrical supplies—retail



5240 Electrical supplies- retail  
 3431 Electrical transmission and distribution equipment—manufacturing  
 4812 Electric generation plants  
 4813 Electricity regulating substations  
 3434 Electric lighting and wiring equipment -manufacturing  
 4811 Electric transmission right-of-way  
 481 Electric utility  
 3312 Electrometallurgical products - manufacturing  
 3437 Electronic components and accessories- -manufacturing  
 5163 Electronic parts and equipment—wholesale  
 2783 Electrotyping and stercotyping  
 336 Employment services  
 3360 Employment services  
 3591 Engineering and architectural services  
 351 Engineering, laboratory, and scientific and research instruments and associated equipment-- manufacturing  
 3510 Engineering, laboratory, and scientific and research instruments and associated equipment - manufacturing  
 3421 Engines and turbines- -manufacturing  
 721 Entertainment assembly  
 2642 Envelope- manufacturing  
 3184 Equipment and supplies for service establishments -wholesale  
 3394 Equipment rental and leasing services  
 371 Executive, legislative, and judicial functions  
 3710 Executive, legislative, and judicial functions  
 7232 Exhibition halls  
 3892 Explosives—manufacturing  
 452 Expressways  
 4520 Expressways

## F

4 Fabricated metal products—manufacturing  
 4494 Fabricated structural metal products - manufacturing  
 4498 Fabricated wire products (miscellaneous products)—manufacturing  
 311 Fairgrounds  
 31 Fairgrounds and amusement parks  
 65 Family clothing - retail  
 650 Family clothing—retail  
 96 Farm and garden supplies- retail  
 252 Farm equipment - retail  
 422 Farm machinery and equipment—manufacturing  
 182 Farm machinery and equipment -wholesale  
 15 Farm products (raw materials) - wholesale  
 371 Farm products warehousing and storage (excluding stockyards)  
 16 Farms and ranches (livestock other than dairy)  
 169 Farms and ranches (other livestock) , NEC  
 161 Farms and ranches (predominately cattle)  
 164 Farms and ranches (predominately goat)

- 8162 Farms and ranches (predominantly hog)
- 8163 Farms and ranches (predominately sheep)
- 813 Farms (field crops other than fiber or cash grain crops)
- 8130 Farms (field crops other than fiber or cash grain crops)
- 818 Farms (general —no predominance)
- 8180 Farms (general —no predominance)
- 8194 Farms or ranches (predominantly horse raising)
- 8119 Farms (other type fiber crops)
- 812 Farms (predominant crop, cash grains)
- 8120 Farms (predominant crop, cash grains)
- 8111 Farms (predominant crop, cotton)
- 811 Farms (predominant crop, fibers)
- 8141 Farms (predominant crop, fruits)
- 814 Farms (predominant crop, fruits, tree nuts, or vegetables)
- 8142 Farms (predominant crop, tree nuts)
- 8143 Farms (predominant crop, vegetables)
- 815 Farms (predominantly dairy products)
- 8150 Farms (predominantly dairy products)
- 817 Farms (predominantly poultry)
- 8170 Farms (predominantly poultry)
- 2291 Felt goods (except woven felts and hats)- manufacturing
- 8516 Ferroalloy ore (except vanadium) mining
- ✓ 61 Finance, insurance, and real estate services
- 3253 Fine earthenware (whiteware) table and kitchen articles—manufacturing
- 8411 Finfish fisheries
- ✓ 6722 Fire protection and related activities
- 5422 Fish and seafoods—retail
- 5145 Fish and seafoods—wholesale
- 8421 Fish hatcheries
- 841 Fisheries and marine products
- 842 Fishery services
- 84 Fishing activities and related services
- 321 Flat glass manufacturing
- 3210 Flat glass—manufacturing
- 2186 Flavor extracts and flavoring sirups manufacturing, NEC
- 5712 Floor coverings—retail
- 224 Floor coverings (rugs and carpets) - manufacturing
- 2240 Floor coverings (rugs and carpets)—manufacturing
- 5991 Florists—retail
- 2141 Flour and other grain mill products
- 2125 Fluid milk processing
- 21 Food and kindred products manufacturing
- 6374 Food lockers (with or without food preparation facilities)
- 2364 Footwear (except rubber) - manufacturing
- 5133 Footwear —wholesale
- 8321 Forest nurseries
- 921 Forest reserves
- 9211 Forest reserves (wilderness areas)

9212 Forest reserves (wildlife refuges)  
 83 Forestry activities and related services  
 832 Forestry services  
 1221 Fraternity and sorority houses  
 451 Freeways  
 4510 Freeways  
 4021 Freight forwarding services  
 2136 Fresh or frozen packaged fish and seafoods  
 2137 Frozen fruits, fruit juices, vegetables, and specialties  
 5147 Fruits and vegetables (fresh)—wholesale  
 543 Fruits and vegetables—retail  
 5430 Fruits and vegetables—retail  
 5981 Fuel and ice dealers (except fuel oil and bottled gas dealers)—retail  
 598 Fuel and ice—retail  
 5982 Fuel oil—retail  
 6241 Funeral and crematory services  
 624 Funeral and crematory services; cemeteries  
 3996 Fur dressing and dyeing  
 237 Fur goods—manufacturing  
 2370 Fur goods—manufacturing  
 25 Furniture and fixtures—manufacturing  
 5197 Furniture and homefurnishings—wholesale  
 571 Furniture, homefurnishings, and equipment—retail  
 5711 Furniture—retail  
 6252 Fur repair and storage services  
 568 Furriers and fur apparel—retail  
 5680 Furriers and fur apparel—retail

## G

553 Gasoline service stations  
 5530 Gasoline service stations  
 4821 Gas pipeline right-of-way  
 4824 Gas pressure control stations  
 4822 Gas production plants  
 482 Gas utility  
 661 General contract construction services  
 3426 General industrial machinery and equipment—manufacturing  
 7511 General resorts  
 5392 General stores—retail  
 6376 General warehousing and storage  
 5995 Gifts, novelties, and souvenirs  
 322 Glass and glassware (pressed or blown)—manufacturing  
 3221 Glass containers—manufacturing  
 2891 Glue and gelatin—manufacturing  
 7394 Go-cart tracks  
 8514 Gold and silver ore—mining  
 7412 Golf courses (with country club)  
 7411 Golf courses (without country club)

7393 Golf driving ranges  
 67 Governmental services  
 214 Grain mill products —manufacturing  
 5152 Grain—wholesale  
 276 Greeting card—manufacturing  
 2760 Greeting card manufacturing  
 8212 Grist milling services  
 514 Groceries and related products—wholesale  
 5141 Groceries (general line)—wholesale  
 541 Groceries (with or without meat)—retail  
 5410 Groceries (with or without meat)—retail  
 752 Group or organized camps  
 7520 Group or organized camps  
 12 Group quarters  
 286 Gum and wood chemicals—manufacturing  
 2860 Gum and wood chemicals—manufacturing  
 3411 Guns, howitzers, mortars, and related equipment—manufacturing  
 7425 Gymnasiums and athletic clubs  
 3265 Gypsum products—manufacturing

## ■

2367 Handbags and other personal leather goods —manufacturing  
 525 Hardware and farm equipment—retail  
 517 Hardware, plumbing, heating equipment, and supplies—wholesale  
 5251 Hardware—retail  
 5171 Hardware—wholesale  
 2422 Hardwood dimension and flooring—manufacturing  
 235 Hats, caps, and millinery—manufacturing  
 2350 Hats, caps, and millinery —manufacturing  
 5961 Hay, grains, and feeds—retail  
 7513 Health resorts  
 522 Heating and plumbing equipment—retail  
 5220 Heating and plumbing equipment—retail  
 3493 Heating apparatus (except electrical) and plumbing fixtures —  
 manufacturing  
 4391 Heliport landing/takeoff pads  
 5153 Hides, skins, and raw furs—wholesale  
 45 Highway and street right-of-way  
 7191 Historic and monument sites  
 616 Holding and investment services  
 6160 Holding and investment services  
 5157 Horses and mules —wholesale  
 8291 Horticultural services  
 8192 Horticultural specialties  
 6513 Hospital services  
 151 Hotels, tourist courts, and motels  
 1510 Hotels, tourist courts, and motels  
 2392 Housefurnishings (except curtains and draperies)—manufacturing

- 3433 Household appliances —manufacturing
- 572 Household appliances— retail
- 5720 Household appliances —retail
- 251 Household furniture—manufacturing
- 2510 Household furniture— —manufacturing
- 6375 Household goods warehousing and storage
- 11 Household units
- 110 Household units
- 1100 Household units
- 7515 Hunting and fishing camps

## I

- 2124 Ice cream and frozen desserts— —manufacturing
- 2197 Ice —manufacturing
- 7414 Ice skating
- 281 Industrial inorganic and organic chemicals —manufacturing
- 2810 Industrial inorganic and organic chemicals—manufacturing
- 2362 Industrial leather belting and packing —manufacturing
- 4856 Industrial waste disposals
- 352 Instruments for measuring, controlling, and indicating physical characteristics—manufacturing
- 6142 Insurance agents, brokers, and services
- 6141 Insurance carriers
- 614 Insurance carriers, agents, brokers, and services
- 332 Iron and steel foundries
- 3320 Iron and steel foundries
- 8511 Iron ore —mining
- 4834 Irrigation distribution channels

## J

- 3912 Jewelers' findings and materials —manufacturing
- 3911 Jewelry and precious metals —manufacturing
- 597 Jewelry — retail
- 5970 Jewelry— retail
- 391 Jewelry, silverware, and plated ware —manufacturing
- 6822 Junior colleges

## K

- 222 Knit goods—manufacturing
- 2220 Knit goods—manufacturing

## L

- 6993 Labor unions and similar labor organizations
- 2292 Lace goods—manufacturing
- 932 Lakes
- 9320 Lakes

- 3994 Lamp shades—manufacturing
- 3913 Lapidary work
- 6214 Laundering and dry cleaning (self-service)
- 621 Laundering, dry cleaning, and dyeing services
- 6211 Laundering, dry cleaning, and dyeing services (except rugs)
- 8513 Lead and zinc ore—mining
- 5154 Leaf tobacco—wholesale
- 236 Leather and leather products—manufacturing
- 2384 Leather and sheep lined clothing—manufacturing
- 2365 Leather gloves and mittens
- 2361 Leather tanning and finishing
- 652 Legal services
- 6520 Legal services
- 7214 Legitimate theaters
- 7111 Libraries
- 8523 Lignite coal—mining
- 3264 Lime products—manufacturing
- 533 Limited price variety stores—retail
- 5330 Limited price variety stores—retail
- 6212 Linen supply and industrial laundry services
- 3992 Linoleum, asphalted-felt-base, and other hard surface floor cover manu-  
facturing, NEC
- 592 Liquor—retail
- 5920 Liquor—retail
- 5156 Livestock—wholesale
- 456 Local access streets
- 4560 Local access streets
- 241 Logging camps and logging contractors
- 2410 Logging camps and logging contractors
- 2991 Lubricating oils and greases—manufacturing
- 2366 Luggage—manufacturing
- 5198 Lumber and construction materials—wholesale
- 521 Lumber and other building materials—retail
- 24 Lumber and wood products (except furniture)—manufacturing
- 5211 Lumber yards—retail

## **M**

- 2198 Macaroni, spaghetti, vermicelli, and noodles—manufacturing
- 518 Machinery, equipment, and supplies—wholesale
- 342 Machinery (except electrical)—manufacturing
- 532 Mail order houses—retail
- 5320 Mail order houses—retail
- 2181 Malt liquors—manufacturing
- 2182 Malt—manufacturing
- 275 Manifold business forms—manufacturing
- 2750 Manifold business forms—manufacturing
- 2 Manufacturing
- 3 Manufacturing

**744** **Marinas**  
**5591** **Marine craft and accessories—retail**  
**44** **Marine craft transportation**  
**441** **Marine terminals**  
**4414** **Marine terminals (commercial fishing)**  
**4412** **Marine terminals (freight)**  
**4411** **Marine terminals (passenger)**  
**4413** **Marine terminals (passenger and freight)**  
**6624** **Masonry, stonework, tile setting, and plastering services**  
**3993** **Matches—manufacturing**  
**5146** **Meat and meat products—wholesale**  
**2111** **Meat packing—manufacturing**  
**211** **Meat products—manufacturing**  
**542** **Meats and fish—retail**  
**5421** **Meats—retail**  
**3521** **Mechanical measuring and controlling instruments (except automatic temperature controls)—manufacturing**  
**651** **Medical and other health services**  
**6517** **Medical clinics out-patient services**  
**6514** **Medical laboratory services**  
**2832** **Medicinal chemicals and botanical products—manufacturing**  
**122** **Membership lodgings**  
**561** **Men's and boys' clothing and furnishings—retail**  
**5610** **Men's and boys' clothing and furnishings—retail**  
**232** **Men's, youths', and boys' furnishings, work clothing, and allied garments—manufacturing**  
**2320** **Men's, youths', and boys' furnishings, work clothing, and allied garments—manufacturing**  
**231** **Men's, youths', and boys' suits, coats, and overcoats—manufacturing**  
**2310** **Men's, youths', and boys' suits, coats, and overcoats—manufacturing**  
**534** **Merchandise vending machine operators—retail**  
**5340** **Merchandise vending machine operators—retail**  
**3491** **Metal cans—manufacturing**  
**3551** **Metal mining—services**  
**851** **Metal ore mining**  
**5191** **Metals and minerals (except petroleum products and scrap)—wholesale**  
**3496** **Metal stamping—manufacturing**  
**3424** **Metalworking machinery and equipment—manufacturing**  
**6755** **Military administration or command centers**  
**675** **Military bases and reservations**  
**6756** **Military communication centers**  
**6752** **Military defense installations**  
**6754** **Military maintenance centers**  
**6753** **Military storage depots and transportation centers**  
**6751** **Military training bases**  
**2431** **Millwork**  
**243** **Millwork, veneer, plywood, and prefabricated structural wood products—manufacturing**

7392 Miniature golf  
 85 Mining activities and related services  
 854 Mining and quarrying of nonmetallic minerals (except fuels)  
 855 Mining services  
 238 Miscellaneous apparel and accessories—manufacturing  
 39 Miscellaneous manufacturing, NEC  
 314 Miscellaneous plastic products—manufacturing  
 3140 Miscellaneous plastic products—manufacturing  
 69 Miscellaneous services  
 14 Mobile home parks or courts  
 140 Mobile home parks or courts  
 1400 Mobile home parks or courts  
 1252 Monasteries  
 3995 Morticians' goods—manufacturing  
 6396 Motion picture distribution and services  
 397 Motion picture production  
 3970 Motion picture production  
 7212 Motion picture theaters  
 3445 Motorcycles, bicycles, and parts—manufacturing  
 4222 Motor freight garaging and equipment maintenance  
 4221 Motor freight terminals  
 422 Motor freight transportation  
 511 Motor vehicles and automotive equipment—wholesale  
 3441 Motor vehicles and motor vehicle equipment—manufacturing  
 5511 Motor vehicles (new and used cars)—retail  
 551 Motor vehicles—retail  
 42 Motor vehicles transportation  
 5512 Motor vehicles (used cars only)—retail  
 7112 Museums  
 392 Musical instruments and parts—manufacturing  
 3920 Musical instruments and parts—manufacturing  
 5732 Music supplies—retail

## **N**

4823 Natural or manufactured gas storage and distribution points  
 712 Nature exhibitions  
 5993 Newspapers and magazines—retail  
 271 Newspapers: publishing, publishing and printing  
 2710 Newspapers: publishing, publishing and printing  
 635 News syndicate services  
 6350 News syndicate services  
 92 Noncommercial forest development  
 336 Nonferrous foundries  
 3360 Nonferrous foundries  
 8554 Nonmetallic mining (except fuel)—services  
 922 Nonreserve forests (undeveloped)  
 9220 Nonreserve forests (undeveloped)  
 681 Nursery, primary, and secondary education



- 6811 Nursery schools
- 1231 Nurses' homes

**●**

- 934 Oceans and seas
- 9340 Oceans and seas
- 3427 Office, computing, and accounting machines—manufacturing
- 252 Office furniture manufacturing
- 2520 Office furniture manufacturing
- 355 Ophthalmic goods—manufacturing
- 3550 Ophthalmic goods—manufacturing
- 5996 Optical goods retail
- 353 Optical instruments and lenses—manufacturing
- 3530 Optical instruments and lenses—manufacturing
- 341 Ordnance and accessories
- 1242 Orphanages
- 3542 Orthopedic, prosthetic, and surgical appliances and supplies—manufacturing
- 6319 Other advertising services, NEC
- 8219 Other agricultural processing services, NEC
- 829 Other agricultural related activities, NEC
- 8299 Other agricultural related activities, NEC
- 819 Other agriculture and related activities, NEC
- 8199 Other agriculture and related activities, NEC
- 439 Other aircraft transportation, NEC
- 4399 Other aircraft transportation, NEC
- 4319 Other airports and flying fields, NEC
- 739 Other amusements, NEC
- 7399 Other amusements, NEC
- 8229 Other animal husbandry services, NEC
- 6419 Other automobile services (except repair and wash), NEC
- 639 Other business services, NEC
- 6399 Other business services, NEC
- 4219 Other bus transportation, NEC
- 289 Other chemicals and allied products manufacturing, NEC
- 2899 Other chemicals and allied products manufacturing, NEC
- 4759 Other combined radio and television communication, NEC
- 8319 Other commercial forestry production, NEC
- 479 Other communication, NEC
- 4790 Other communication, NEC
- 2619 Other converted paper and paperboard products (except containers and boxes) manufacturing, NEC
- 6749 Other correctional institutions, NEC
- 6129 Other credit services (other than banks), NEC
- 719 Other cultural activities and nature exhibitions, NEC
- 7199 Other cultural activities and nature exhibitions, NEC
- 7119 Other cultural activities, NEC
- 79 Other cultural, entertainment, and recreational activities, NEC

790 Other cultural, entertainment, and recreational activities, NEC  
 7900 Other cultural, entertainment, and recreational activities, NEC  
 5129 Other drugs, chemicals, and allied products wholesale, NEC  
 6349 Other dwelling and building services, NEC  
 3439 Other electrical machinery, equipment, and supplies manufacturing, NEC  
 4819 Other electric utility, NEC  
 7219 Other entertainment assembly, NEC  
 349 Other fabricated metal products manufacturing, NEC  
 3499 Other fabricated metal products manufacturing, NEC  
 319 Other fabricated rubber products manufacturing, NEC  
 3190 Other fabricated rubber products manufacturing, NEC  
 239 Other fabricated textile products manufacturing, NEC  
 2399 Other fabricated textile products manufacturing, NEC  
 5969 Other farm and garden supplies retail, NEC  
 5159 Other farm products wholesale, NEC  
 619 Other finance, insurance, and real estate services, NEC  
 6190 Other finance, insurance, and real estate services, NEC  
 8419 Other fisheries and marine products, NEC  
 849 Other fishery activities and related services, NEC  
 8490 Other fishery activities and related services, NEC  
 8429 Other fishery services, NEC  
 219 Other food preparations and kindred products manufacturing, NEC  
 2199 Other food preparations and kindred products manufacturing, NEC  
 9219 Other forest reserves, NEC  
 839 Other forestry activities and related services, NEC  
 8390 Other forestry activities and related services, NEC  
 8329 Other forestry services, NEC  
 259 Other furniture and fixtures manufacturing, NEC  
 2599 Other furniture and fixtures manufacturing, NEC  
 5719 Other furniture, homefurnishings, and equipment retail, NEC  
 4829 Other gas utilities, NEC  
 6619 Other general construction contractor services, NEC  
 3229 Other glass and glassware (pressed or blown) manufacturing, NEC  
 5149 Other groceries and related products wholesale, NEC  
 129 Other group quarters, NEC  
 1290 Other group quarters, NEC  
 459 Other highway and street right-of-way, NEC  
 4590 Other highway and street right-of-way, NEC  
 2369 Other leather products manufacturing, NEC  
 249 Other lumber and wood products (except furniture) manufacturing, NEC  
 2499 Other lumber and wood products (except furniture) manufacturing, NEC  
 5189 Other machinery, equipment, and supplies wholesale, NEC  
 3429 Other machinery manufacturing (except electrical), NEC  
 449 Other marine craft transportation, NEC  
 4490 Other marine craft transportation, NEC  
 7449 Other marinas, NEC  
 4419 Other marine terminals, NEC  
 6519 Other medical and health services, NEC

1229 Other membership lodgings, NEC  
 8519 Other metal ore mining, NEC  
 6759 Other military bases and reservations, NEC  
 8549 Other mining and quarrying of nonmetallic minerals (except fuels), NEC  
 8559 Other mining services, NEC  
 2389 Other miscellaneous apparel and accessory manufacturing, NEC  
 7239 Other miscellaneous assembly, NEC  
 399 Other miscellaneous manufacturing, NEC  
 3999 Other miscellaneous manufacturing, NEC  
 699 Other miscellaneous services, NEC  
 6999 Other miscellaneous services, NEC  
 4229 Other motor freight transportation, NEC  
 429 Other motor vehicle transportation, NEC  
 4299 Other motor vehicle transportation, NEC  
 7129 Other nature exhibitions, NEC  
 3419 Other ordnance and accessories manufacturing, NEC  
 769 Other parks, NEC  
 7690 Other parks, NEC  
 629 Other personal services, NEC  
 6290 Other personal services, NEC  
 2999 Other petroleum and coal products manufacturing, NEC  
 299 Other petroleum refining and related industries, NEC  
 491 Other pipeline right-of-way and pressure control stations, NEC  
 4919 Other pipeline right-of-way and pressure control stations, NEC  
 7429 Other playground and athletic areas, NEC  
 3259 Other pottery and related products manufacturing, NEC  
 339 Other primary metal industries, NEC  
 3390 Other primary metal industries, NEC  
 3339 Other primary smelting and refining of nonferrous metals, NEC  
 279 Other printing and publishing, NEC  
 2790 Other printing and publishing, NEC  
 2789 Other printing trade service industries, NEC  
 659 Other professional services, NEC  
 6599 Other professional services, NEC  
 6729 Other protective functions and their related activities, NEC  
 729 Other public assembly, NEC  
 7290 Other public assembly, NEC  
 4739 Other radio communication, NEC  
 4119 Other railroad transportation, NEC  
 4129 Other rapid rail transit and street railway transportation, NEC  
 6159 Other real estate and related services, NEC  
 749 Other recreation, NEC  
 7499 Other recreation, NEC  
 6919 Other religious activities, NEC  
 1259 Other religious quarters, NEC  
 649 Other repair services, NEC  
 6499 Other repair services, NEC  
 1239 Other residence halls or dormitories, NEC

19 Other residential, NEC  
 190 Other residential, NEC  
 1900 Other residential, NEC  
 7519 Other resorts, NEC  
 89 Other resource production and extraction, NEC  
 890 Other resource production and extraction, NEC  
 8900 Other resource production and extraction, NEC  
 569 Other retail trade—apparel and accessories, NEC  
 5690 Other retail trade—apparel and accessories, NEC  
 559 Other retail trade--automotive, marine craft, aircraft, and accessories,  
 NEC  
 5599 Other retail trade- automotive, marine craft, aircraft, and accessories,  
 NEC  
 549 Other retail trade—food, NEC  
 5499 Other retail trade- food, NEC  
 539 Other retail trade—general merchandise, NEC  
 59 Other retail trade, NEC  
 599 Other retail trade, NEC  
 5999 Other retail trade, NEC  
 4849 Other sewage disposal, NEC  
 4859 Other solid waste disposal, NEC  
 6629 Other special construction trade services, NEC  
 6839 Other special training and schooling, NEC  
 7419 Other sports activities, NEC  
 7229 Other sports assembly, NEC  
 3249 Other structural clay products manufacturing, NEC  
 4729 Other telegraph communication, NEC  
 4719 Other telephone communication, NEC  
 4749 Other television communication, NEC  
 229 Other textile goods manufacturing, NEC  
 2299 Other textile goods manufacturing, NEC  
 159 Other transient lodgings, NEC  
 1590 Other transient lodgings, NEC  
 49 Other transportation, communication, and utilities, NEC  
 499 Other transportation, communication, and utilities, NEC  
 4990 Other transportation, communication, and utilities, NEC  
 3449 Other transportation equipment manufacturing, NEC  
 4929 Other transportation services and arrangements, NEC  
 99 Other undeveloped land and water areas, NEC  
 990 Other undeveloped land and water areas, NEC  
 9900 Other undeveloped land and water areas, NEC  
 489 Other utilities, NEC  
 4890 Other utilities, NEC  
 6379 Other warehousing and storage, NEC  
 939 Other water areas, NEC  
 9390 Other water areas, NEC  
 4839 Other water utilities and irrigation, NEC  
 519 Other wholesale trade, NEC

- 5199 Other wholesale trade, NEC
- 6312 Outdoor advertising services

## **P**

- 4922 Packing and crating services
- 2293 Padding and upholstery filling manufacturing
- 523 Paint, glass, and wallpaper retail
- 5230 Paint, glass, and wallpaper retail
- 6622 Painting, paperhanging, and decorating services
- 285 Paints, varnishes, lacquers, enamels, and allied products- manufacturing
- 2850 Paints, varnishes, lacquers, enamels, and allied products—manufacturing
- 26 Paper and allied products—manufacturing
- 5196 Paper and paper products -wholesale
- 265 Paperboard containers and boxes manufacturing
- 2650 Paperboard containers and boxes—manufacturing
- 263 Paperboard manufacturing
- 2630 Paperboard—manufacturing
- 2641 Paper coating and glazing
- 262 Paper (except building paper)—manufacturing
- 2620 Paper (except building paper)- manufacturing
- 76 Parks
- 761 Parks— general recreation
- 7610 Parks— general recreation
- 762 Parks - leisure and ornamental
- 7620 Parks —leisure and ornamental
- 453 Parkways
- 4530 Parkways
- 254 Partitions, shelving, lockers, and office and store fixtures manufacturing
- 2540 Partitions, shelving, lockers, and office and store fixtures manufacturing
- 292 Paving and roofing materials manufacturing
- 2921 Paving mixtures and blocks manufacturing
- 7391 Penny arcades
- 394 Pens, pencils, and other office and artists' materials manufacturing
- 3940 Pens, pencils, and other office and artists' materials manufacturing
- 2844 Perfumes, cosmetics and other toilet preparations- manufacturing
- 272 Periodicals: publishing, publishing and printing
- 2720 Periodicals: publishing, publishing and printing
- 62 Personal services
- 5192 Petroleum bulk stations and terminals wholesale
- 4911 Petroleum pipeline right-of-way
- 4912 Petroleum pressure control stations
- 291 Petroleum refining
- 2910 Petroleum refining
- 29 Petroleum refining and related industries
- 2833 Pharmaceutical preparations- manufacturing
- 2782 Photoengraving
- 6395 Photofinishing services
- 356 Photographic equipment and supplies —manufacturing

- 3560 Photographic equipment and supplies—manufacturing
- 622 Photographic services (including commercial)
- 6220 Photographic services (including commercial)
- ✓6511 Physicians' services
- 2135 Pickling fruits and vegetables, vegetable sauces and seasonings, salad dressings --manufacturing
- 7121 Planctaria
- 282 Plastics materials and synthetic resins, synthetic rubber, synthetic and other manmade fibers (except glass)—manufacturing
- 2820 Plastics materials and synthetic resins, synthetic rubber, synthetic and other manmade fibers (except glass) --manufacturing
- 7423 Playfield or athletic field
- 7422 Playgrounds
- 742 Playgrounds and athletic areas
- 7421 Play lot or tot lot
- 2395 Pleating, decorative and novelty stitching, and tucking for the trade
- 5172 Plumbing and heating equipment and supplies—wholesale
- 6621 Plumbing, heating, and air conditioning services
- 6721 Police protection and related activities
- 3254 Porcelain electrical supplies—manufacturing
- 673 Postal services
- 6730 Postal services
- 325 Pottery and related products --manufacturing
- 5143 Poultry and poultry products—wholesale
- 2113 Poultry and small game dressing and packing
- 8223 Poultry hatchery services
- 2433 Prefabricating wooden buildings and structural members—manufacturing
- 2142 Preparing feeds for animals and fowls
- 2646 Pressed and molded pulp goods—manufacturing
- 6251 Pressing, alteration and garment repair; laundry and dry cleaning pickup services (only)
- 6812 Primary (elementary) schools
- 33 Primary metal industries
- 3334 Primary production of aluminum
- 3331 Primary smelting and refining of copper
- 3332 Primary smelting and refining of lead
- 333 Primary smelting and refining of nonferrous metals
- 3333 Primary smelting and refining of zinc
- 2893 Printing ink—manufacturing
- 27 Printing, publishing, and allied industries
- 278 Printing trade service industries
- 6741 Prisons
- 2294 Processing waste and recovering fibers and flock
- 5183 Professional equipment and supplies - wholesale
- 6992 Professional membership organizations
- 6823 Professional schools
- 35 Professional, scientific, and controlling instruments; photographic and optical goods; watches and clocks—manufacturing

- 65 Professional services
- 672 Protective functions and their related activities
- 72 Public assembly
- 723 Public assembly, miscellaneous purposes
- 253 Public building and related furniture manufacturing
- 2530 Public building and related furniture manufacturing
- 261 Pulp—manufacturing
- 2610 Pulp manufacturing

## Q

## R

- 7223 Race tracks
- 4751 Radio and television broadcasting studios, only (combined systems)
- 475 Radio and television communication (combined systems)
- 3435 Radio and television receiving sets (except communication types) — manufacturing
- 6492 Radio and television repair services
- 4731 Radio broadcasting studios (only)
- 473 Radio communication
- 5731 Radios and televisions—retail
- 573 Radios, televisions, and music supplies —retail
- 4732 Radio transmitting stations and towers
- 4116 Railroad equipment and maintenance
- 3444 Railroad equipment—manufacturing
- 41 Railroad, rapid rail transit, and street railway transportation
- 4111 Railroad right-of-way (excluding switching and marshaling yards)
- 4112 Railroad switching and marshaling yards
- 4114 Railroad terminals (freight)
- 4113 Railroad terminals (passenger)
- 4115 Railroad terminals (passenger and freight)
- 411 Railroad transportation
- 2383 Raincoats and other waterproof outer garments—manufacturing
- 8191 Range and grassland pastures (not farm or ranch)
- 4123 Rapid rail transit and street railway equipment maintenance
- 4122 Rapid rail transit and street railway passenger terminals
- 4121 Rapid rail transit and street railway right-of-way
- 412 Rapid rail transit and street railway transportation
- 6152 Real estate agents, brokers, and management services
- 615 Real estate and related services
- 6155 Real estate operative builders
- 6151 Real estate operators (except developers) and lessors
- 6154 Real estate subdividing and developing services
- 313 Reclaiming rubber
- 3130 Reclaiming rubber
- 74 Recreational activities
- 7424 Recreation centers (general)
- 1253 Rectories
- 6373 Refrigerated warehousing (except food lockers)
- 4855 Refuse disposals

4851 Refuse incineration  
 691 Religious activities  
 125 Religious quarters  
 64 Repair services  
 6391 Research, development, and testing services  
 123 Residence halls or dormitories  
 A Residential  
 13 Residential hotels  
 130 Residential hotels  
 1300 Residential hotels  
 751 Resorts  
 75 Resorts and group camps  
 8 Resource production and extraction  
 ✓56 Retail trade—apparel and accessories  
 : 55 Retail trade—automotive, marine craft, aircraft, and accessories  
 : 52 Retail trade—building materials, hardware, and farm equipment  
 ✓58 Retail trade—eating and drinking  
 : 54 Retail trade—food  
 57 Retail trade—furniture, home furnishings, and equipment  
 53 Retail trade—general merchandise  
 1241 Retirement homes  
 124 Retirements homes and orphanages  
 6494 Reupholstery and furniture repair services  
 2144 Rice milling  
 7416 Riding stables  
 931 Rivers, streams, or creeks  
 9310 Rivers, streams, or creeks  
 2195 Roasting coffee and coffee products—manufacturing  
 2382 Robes and dressing gowns—manufacturing  
 7415 Roller skating  
 3352 Rolling, drawing, and extruding of aluminum  
 3351 Rolling, drawing, and extruding of copper  
 335 Rolling, drawing, and extruding of nonferrous metals  
 3353 Rolling, drawing, and extruding of nonferrous metals (except copper and  
     aluminum)  
 6626 Roofing and sheet metal services  
 121 Rooming and boarding houses  
 1210 Rooming and boarding houses  
 31 Rubber and miscellaneous plastic products—manufacturing  
 312 Rubber footwear—manufacturing  
 3120 Rubber footwear—manufacturing  
 6215 Rug cleaning and repair services

## **S**

8543 Sand and gravel—quarrying  
 6516 Sanitariums, convalescent, and rest home services  
 4854 Sanitary land fills  
 2647 Sanitary paper products—manufacturing



- 2112 Sausages and other prepared meat products—manufacturing
- 6121 Savings and loan associations
- 242 Sawmills and planing mills
- 2421 Sawmills and planing mills, general
- 5193 Scrap and waste materials—wholesale
- 3495 Screw machine products and bolts, nuts, screws, rivets, and washers—  
manufacturing
- 6813 Secondary schools
- 334 Secondary smelting and refining of nonferrous metals and alloys
- 3340 Secondary smelting and refining of nonferrous metals and alloys
- 5932 Secondhand merchandise— retail
- 6134 Security and commodity allied services
- 613 Security and commodity brokers, dealers, exchanges, and services
- 6133 Security and commodity exchanges
- 6131 Security brokers, dealers, and floatation services
- 3428 Service industry machines manufacturing
- 6 Services
- 484 Sewage disposal
- 4843 Sewage pressure control stations
- 4842 Sewage sludge drying beds
- 4841 Sewage treatment plants
- 8412 Shellfish fisheries
- 3443 Ship and boat building and repairing
- 6253 Shoe repair, shoe shining, and hat cleaning services
- 566 Shoes—retail
- 5660 Shoes— retail
- 2196 Shortening, table oils, margarine, and other edible fats and oils—manu-  
facturing
- 3414 Sighting and fire control equipment—manufacturing
- 3997 Signs and advertising displays manufacturing
- 3914 Silverware and plated ware— manufacturing
- 7418 Skiing and tobogganing
- 7514 Ski resorts
- 3416 Small arms ammunition—manufacturing
- 3415 Small arms—manufacturing
- 2841 Soap and detergents (except specialty cleaners) manufacturing
- 284 Soap, detergents and cleaning preparations, perfumes, cosmetics, and  
other toilet preparations manufacturing
- 485 Solid waste disposal
- 2192 Soybean oil milling
- 662 Special construction trade services
- 3425 Special industry machinery (except metalworking machinery)—manu-  
facturing
- 2842 Specialty cleaning, polishing, and sanitation preparations (except soap and  
detergents) manufacturing
- 2429 Special sawmill products manufacturing, NEC
- 683 Special training and schooling
- 595 Sporting goods and bicycles—retail

5951 Sporting goods— retail  
 711 Sports activities  
 722 Sports assembly  
 7221 Stadia  
 5942 Stationery— retail  
 3315 Steel pipe and tubes— manufacturing  
 3313 Steel wire drawing and steel nails and spikes— manufacturing  
 6339 Stenographic services and other duplicating and mailing services, NEC  
 6372 Stockyards  
 32 Stone, clay, and glass products— manufacturing  
 324 Structural clay products— manufacturing  
 216 Sugar— manufacturing  
 2160 Sugar— manufacturing  
 2843 Surface active agents, finishing agents, sulfonated oils and assistants -  
     manufacturing  
 3541 Surgical and medical instruments and apparatus— manufacturing  
 354 Surgical, medical, and dental instruments and supplies— manufacturing  
 743 Swimming areas  
 7431 Swimming beaches  
 7432 Swimming pools

## **T**

3413 Tanks and tank components— manufacturing  
 4291 Taxical transportation  
 472 Telegraph communication  
 4721 Telegraph message centers  
 4722 Telegraph transmitting and receiving stations (only)  
 471 Telephone communication  
 4711 Telephone exchange stations  
 4712 Telephone relay towers (microwave)  
 4741 Television broadcasting studios (only)  
 474 Television communication  
 4742 Television transmitting stations and relay towers  
 7413 Tennis courts  
 2393 Textile bags— manufacturing  
 22 Textile mill products— manufacturing  
 8317 Timber and tree products production (mixed uses)  
 8314 Timber production— mixed uses  
 8311 Timber production —predominantly for pulp wood  
 8312 Timber production —predominantly for saw logs  
 8313 Timber production— predominantly for veneer logs  
 2296 Tire cord and fabric— manufacturing  
 311 Tires and inner tubes— manufacturing  
 552 Tires, batteries, and accessories— retail  
 5520 Tires, batteries, and accessories— retail  
 3110 Tires and inner tubes— manufacturing  
 5113 Tires and tubes— wholesale  
 6153 Title abstracting services

- 5194 Tobacco and tobacco products—wholesale
- 3963 Tobacco (chewing and smoking) and snuff—manufacturing
- 396 Tobacco—manufacturing
- 3964 Tobacco stemming and redrying
- 393 Toys, amusement, sporting, and athletic goods—manufacturing
- 3930 Toys, amusement, sporting, and athletic goods—manufacturing
- 5 Trade
- 6396 Trading stamp services
- 15 Transient lodgings
- 4 Transportation, communication, and utilities
- 5185 Transportation equipment and supplies (except motor vehicles)—wholesale
- 344 Transportation equipment—manufacturing
- 492 Transportation services and arrangements
- 4924 Transportation ticket services
- 4923 Travel arranging services
- 8315 Tree products production—predominantly gum extracting (except pine gum) and bark
- 8316 Tree products production—predominantly pine gum extraction
- 2781 Typesetting

#### **U**

- 3998 Umbrellas, parasols, and canes—manufacturing
- 95 Under construction
- 952 Under construction (nonresidential)
- 9520 Under construction (nonresidential)
- 951 Under construction (residential)
- 9510 Under construction (residential)
- ✓91 Undeveloped and unused land area (excluding noncommercial forest development)
- 910 Undeveloped and unused land area (excluding noncommercial forest development)
- 9100 Undeveloped and unused land area (excluding noncommercial forest development)
- 9 Undeveloped land and water areas
- 6821 Universities and colleges
- 682 University, college, junior college, and professional school education
- 6594 Urban planning services
- 48 Utilities

#### **V**

- ✓94 Vacant floor area
- 940 Vacant floor area
- 9400 Vacant floor area
- 2193 Vegetable oil milling (except cottonseed and soybean)
- 2432 Veneer and plywood—manufacturing
- 2591 Venetian blinds and shades—manufacturing
- 8221 Veterinarian services

- 3251 Vitreous china plumbing fixtures, china, earthenware fittings, and bathroom accessories —manufacturing
- 3252 Vitreous china, table, and kitchen articles—manufacturing
- 6831 Vocational or trade schools

## **W**

- 2644 Wallpaper manufacturing
- 637 Warehousing and storage services
- 6493 Watch, clock, and jewelry repair services
- 357 Watches, clocks, clockwork operated devices, and parts manufacturing
- 3570 Watches, clocks, clockwork operated devices, and parts—manufacturing
- 93 Water areas
- 4831 Water pipeline right-of-way
- 4835 Water pressure control stations
- 4833 Water storage
- 4832 Water treatment plants (purification)
- 483 Water utilities and irrigation
- 6628 Water well drilling services
- 692 Welfare and charitable services
- 6920 Welfare and charitable services
- 2146 Wet corn milling
- 51 Wholesale trade
- 6341 Window cleaning services
- 2183 Wine, brandy, and brandy spirits manufacturing
- 563 Women's accessories and specialties—retail
- 5630 Women's accessories and specialties retail
- 234 Women's, misses', children's, and infants' undergarment manufacturing
- 2340 Women's, misses', children's, and infants' undergarment manufacturing
- 233 Women's, misses', juniors', girls', children's, and infants' outerwear manufacturing
- 2330 Women's, misses', juniors', girls', children's, and infants' outerwear manufacturing
- 562 Women's ready-to-wear retail
- 5620 Women's ready-to-wear retail
- 244 Wooden containers manufacturing
- 2440 Wooden containers manufacturing
- 2491 Wood preserving
- 5155 Wool and mohair—wholesale
- 2297 Wool scouring, worsted combing, and towing to top

## **X**

## **Y**

- 225 Yarns and threads manufacturing
- 2250 Yarns and threads manufacturing
- 7141 Yachting clubs

## **Z**

- 7124 Zoos

## *Appendices*

### APPENDIX 1—CODING SYSTEM FOR IDENTIFYING OWNERSHIP

<i>Code</i>	<i>Category</i>	<i>Code</i>	<i>Category</i> <sup>1</sup>
1	Public.	11	Federal.
		12	State.
		13	County.
		14	Township.
		15	Municipal.
		16	Special district.
		19	Other public, NEC.
2	Private.	20	Private.

<sup>1</sup> If it becomes necessary to further subdivide a category into a finer breakdown of ownership, this can be done by adding digits to the right of the present code numbers.

### APPENDIX 2—CODING SYSTEM FOR IDENTIFYING FARMS AND FARM USES

#### *A. Description of System*

Due to the dichotomy of demands for data concerning agricultural land (i.e., by farms as a total management unit and also by the uses made of the individual areas within a farm or farm uses as they will be referred to), a system was devised to meet both of these demands. In order to accomplish this, however, and still maintain the basic system of land use activity categories, only those categories identifying the types of farms were incorporated at the three- and four-digit levels of generalization. The farm uses, on the other hand, were developed into a special series of codes and they are shown in part B of this appendix.

In order to identify and code the types of farms in an agricultural area, the farm uses on each farm must be inventoried and the predominant use determined in accordance with footnotes 1 and 2 under "Resource production and extraction" (code B). The criteria set forth in these footnotes indicate that "predominant land area" cannot be determined by field observation alone nor will "predominant land area" measures necessarily identify dairy, livestock, and poultry farms. If these types of farms are to be distinguished, it will be necessary to determine whether the dairy, livestock, or poultry products comprised 50 percent or more of the total farm products sold in the previous year.

Figure 6 is a schematic outline of a farm and an example of how a farm might be described and coded on a field listing form. Columns 6, 7, 6', and 7' indicate two ways the same data might be coded depending upon the use to which the data will be put. In columns 6 and 7, both the farm uses and the farm type are coded; in columns 6' and 7', only the farm uses are coded.

Figure 6.—An Example of How Farm Types and Farm Uses Can Be Identified and Coded

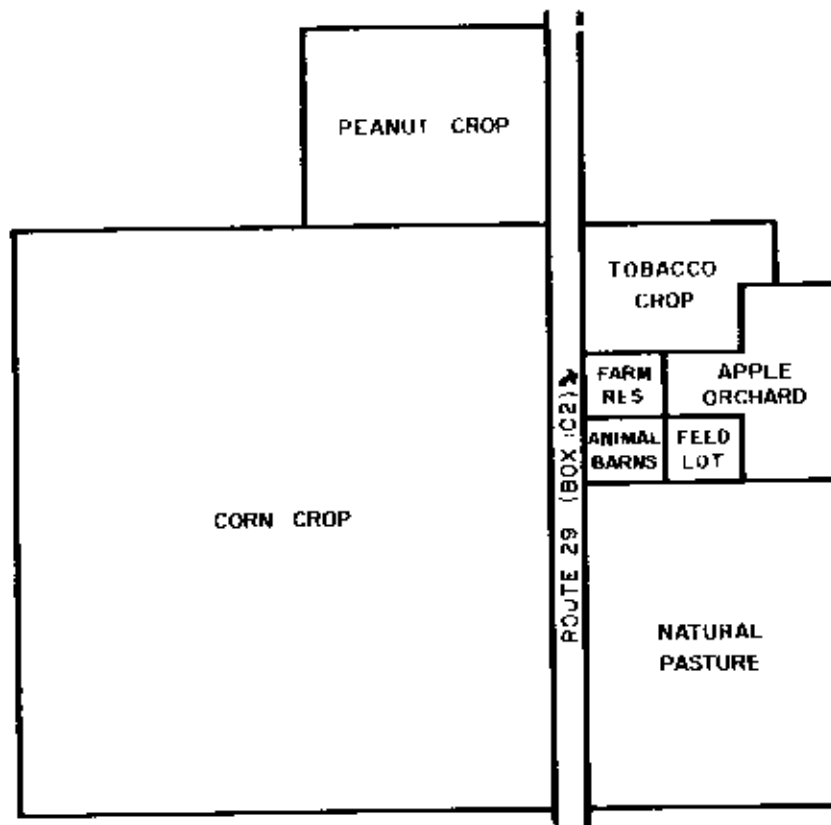

6A.—Outline of Farm

FIELD OPERATION					OFFICE OPERATION		OFFICE OPERATION	
Street No.	Street Name	Description of Activity	Farm Use Description	No. of Acres	Basic Activity Code	Farm Use Code	Basic Activity Code	Farm Use Code
1	2	3	4	5	6	7	8	9
BOX 102	RTE. 29	FARMING	PEANUT CROP	10	—	165	81	165
—	—	—	CORN CROP (CASH GRAIN)	75	—	112	81	165
—	—	—	TOBACCO CROP	5	—	163	81	112
—	—	—	FARM RESIDENCE	1	—	260	81	163
—	—	—	APPLE ORCHARD	7	—	191	81	260
—	—	—	ANIMAL BARNS	1	—	250	81	191
—	—	—	FEED LOT	1	—	240	81	250
—	—	—	NATURAL PASTURE	20	—	181	81	240
BOX 102	RTE. 29	TOTAL	FARM	120	8120	112	81	181
BOX 102	RTE. 29	TOTAL	FARM	120	00	000		

6B.—Example of Land Use Entries on a Field Listing Form

*B. "Farm Use" Codes*

The following is a system of codes to be used to identify the uses made of individual areas within a farm.

<i>Code</i>	<i>Category</i> <sup>1</sup>	<i>Code</i>	<i>Category</i> <sup>2</sup>
11	Grain crops (cash).	111	Barley crop (cash).
		112	Corn crop (cash).
		113	Oats crop (cash).
		114	Rice crop (cash).
		115	Wheat crop (cash).
		119	Other grain crops (cash), NEC.
12	Grain crops (feed).	121	Barley crop (feed).
		122	Corn crop (feed).
		123	Oats crop (feed).
		124	Rice crop (feed).
		125	Wheat crop (feed).
		129	Other grain crops (feed), NEC.
13	Fiber crops.	131	Cotton crop.
		132	Flax crop.
		133	Hemp crop.
		139	Other fiber crops, NEC.
14	Hay and alfalfa crops.	141	Hay crop.
		142	Alfalfa crop.
15	Vegetable crops.	151	Tomato crop.
		152	Strawberry crop.
		153	Celery crop.
		154	Onion crop.
		155	Bean crop.
		156	Carrot crop.
		157	Watermelon crop.
		158	Lettuce crop.
		159	Other vegetable crops, NEC.
16	Other row crops.	161	Sugar beet crop.
		162	Sugar cane crop.
		163	Tobacco crop.
		164	Soybean crop.
		165	Peanut crop.
		169	Other row crops, NEC.
17	Fallow crop land.	170	Fallow crop land.
18	Pasture land.	181	Natural pasture or range.
		182	Rotation pasture or crop land/pasture.
		189	Other pasture land, NEC.
19	Deciduous tree fruit crops.	191	Apple crop.
		192	Peach crop.
		193	Pear crop.
		194	Apricot crop.
		195	Cherry crop.
		196	Plum crop.
		197	Nectarine crop.
		199	Other deciduous tree fruit crops, NEC.

See footnotes at end of table.

<i>Code</i>	<i>Category</i> <sup>1</sup>	<i>Code</i>	<i>Category</i> <sup>2</sup>
20	Citrus tree fruit crops.	201	Orange crop.
		202	Lemon crop.
		203	Lime crop.
		204	Grapefruit crop.
		209	Other citrus tree fruit crops, NEC.
21	Tree nut crop.	211	Pecan crop.
		212	Walnut crop.
		213	Hilbert crop.
		214	Almond crop.
		219	Other tree nut crops, NEC.
22	Vine crops.	221	Grape crop.
		229	Other vine crops, NEC.
23	Bush fruits.	231	Raspberry crop.
		232	Blackberry crop.
		233	Current crop.
		239	Other bush fruit crops, NEC.
24	Feed lot area.	240	Feed lot area.
25	Nonresident farm building area.	250	Nonresident farm building area.
26	Farm residence and associated building area.	260	Farm residence and associated building area.
27	Forests.	271	Forests (nongrazing).
		272	Forests (grazing).
28	Idle agricultural land.	280	Idle agricultural land. <sup>2</sup>
99	Other farm uses, NEC.	990	Other farm uses, NEC.

<sup>1</sup> Crop failures would be shown under the crop planted.

<sup>2</sup> If it becomes necessary to further subdivide a category into a finer breakdown of farm uses, this can be done by adding digits to the right of the present code number.

<sup>3</sup> Code 280 "Idle agricultural land" includes land once in agricultural activity and still available for such use, but is presently not being used for any purpose. This includes agricultural land being taken out of production due to Federal agricultural programs.

### APPENDIX 3—CODING SYSTEM FOR IDENTIFYING STRUCTURES CONTAINING "HOUSEHOLD UNITS"

<i>Code</i>	<i>Category</i>	<i>Code</i>	<i>Category</i> <sup>1</sup>
1	Single family structures. <sup>2</sup>	11	Single units—detached. <sup>3</sup>
		12	Single units—semiattached. <sup>4</sup>
		13	Single units—attached row. <sup>5</sup>
2	Two family structures. <sup>6</sup>	21	Two units—side-by-side.
		22	Two units—one above the other.
3	Multifamily structures. <sup>7</sup>	31	Apartments—walk up.
		32	Apartments—elevator.
4	Converted structures. <sup>8</sup>	41	Converted from—detached.
		42	Converted from—semidetached.
		43	Converted from—attached row.

See footnotes at end of table.



<i>Code</i>	<i>Category</i>	<i>Code</i>	<i>Category</i>
5	Mobile homes.	51	Mobile homes—on permanent foundation.
		52	Mobile homes--not on permanent foundation.
9	Nonresidential structures.	90	Nonresidential structures.*

\* If it becomes necessary to further subdivide a category into a finer breakdown of structure type, this can be done by adding digits to the right of the present code number.

<sup>1</sup> Code 1—"Single family structures" include structures containing one "Household unit" in combination with space for business or professional use provided the buildings are primarily for residential use.

<sup>2</sup> Code 11 "Single units detached" are single "Household units" whose construction is characterized by no common wall or ceiling with any other similar units.

<sup>3</sup> Code 12—"Single units semiattached" are single or "Household units" whose construction is characterized by a common party wall (ground to roof) with a second "Household unit" on an adjoining lot. Where three or more units are connected in this manner (i.e., a common party wall from ground to roof), the structure is coded 13 (Single units attached row).

<sup>4</sup> Code 13—"Single units—attached row" are single "Household units" whose construction is characterized by a common party wall (ground to roof) between similar units on one or both adjoining lots. There must be a minimum of three such units connected in series. If there are only two, the units should be coded 12 (Single units semiattached).

<sup>5</sup> Code 2 "Two family structures" contain two "Household units" which may be one above the other or side-by-side. If built side-by-side, they do not have a common party wall (ground to roof), and they usually have a common attic, basement, heating plant, as well as other common features. This classification includes structures containing two "Household units" in combination with space for business or professional use provided the buildings are primarily residential buildings.

<sup>6</sup> Code 3 "Multifamily structures" contain three or more "Household units" within one structure and are characterized by having a common basement, heating plant, stairs, or entrance. Construction is characterized by both horizontal as well as vertical attachment of "Household units." This classification includes structures containing three or more housing units in combination with space for business or professional use provided the buildings are primarily for residential purposes.

<sup>7</sup> Code 4—"Converted Structures" include structures originally constructed for single family use. They have since been converted for use by two or more families.

<sup>8</sup> Code 90 "Nonresidential structures" include those built and used primarily for nonresidential purposes but may contain one or more "Household units."